



PTO DRIVEN - GRASS COLLECTION SYSTEM

Model# 28120903

Kubota®

Z200

48" & 54" DECKS

MODEL YEAR:

2023-NEWER



OPERATOR'S MANUAL

ASSEMBLY • OPERATION • MAINTENANCE

GRASS COLLECTION SYSTEM

TABLE OF CONTENTS

SECTION	PAGE	SECTION	PAGE
Safety	2	PTO Mount Plate Installation	13
Safety Alert Symbols	3	Lower Frame Tube Installation	14
I INTRODUCTION AND DESCRIPTION	4	Upper Frame Assembly Installation	14
Introduction	4	PTO Assembly Installation	15
Description	4	Belt Installation/Removal & Adjustment	15
Overall Parts List	5	Front Baffle Installation (48" Deck)	16
II OPERATING INSTRUCTIONS	6	Front Baffle Installation (54" Deck)	16-17
General Safety	6	Safety Interlock Installation	17-18
Operation & Tips On Mowing	6	Top Assy To Upper Frame Assy Installation	19
Disengagement Of The PTO Assembly	6	Inlet Installation	19
Unloading The Collection System	6	Hinge Kit Assy Installation	20
III MAINTENANCE	6-7	Even Bag Fill Adjustment	20
Maintenance Checklist	7	Bag Assembly	21
Lubrication	7	Bag Assembly Installation	21
IV PARTS AND SERVICE	7	Blower Cone Installation	22
Parts And Service Information	7	Boot Installation	22
Torque Specifications	8	Length of Hose Adjustment	23
V INSTALLATION FOR USE	9	Upper Hose Installation	23
Recommended Tools & Equipment	9	Lower Hose to Blower Cone Installation	23
Preparation Of Mower	10-11	Lower Hose to Boot Installation	23
Rear Mount Plate Installation	12	Impeller Blade Removal/Replacement	24
Lower Right Mount Plate Installation	12	Weight Kit Installation	25
Top Mount Plates Installation	12	Exploded Parts List	26-30
		Safety Decals	31
		Troubleshooting	32

SAFETY

- 1.** Read the operator's manual carefully and familiarize yourself with the proper use of your attachment. Do not allow anyone who is not acquainted with the Safety Instructions to use your attachment.
- 2.** Know the controls and how to stop them quickly. **READ THE OPERATOR'S MANUAL!**
- 3.** Do not allow children to operate the machine. Do not allow adults to operate it without proper instruction.
- 4.** Be especially watchful of children and pets entering into the area while operating.
- 5.** Keep your eyes and mind on your machine while mowing or operating your attachment. Don't let others distract you.
- 6.** Do not attempt to operate your machine when not in the driver's seat.
- 7.** Always shut off blades and engine when emptying the container.
- 8.** Stop machine, shut off deck attachment, set parking brake, shut off engine and remove ignition key before removing clogs, removing or replacing hose, boot, blower cone, or performing any maintenance.
- 9.** Mow across the face of slopes (not more than 10 degrees); never up and down the face.
- 10.** It is recommended that the container be emptied when half full while operating on slopes. Start mowing on slopes when the container is empty.
- 11.** Inspect your lawn and remove any foreign objects before mowing. Never deliberately run the mower across any foreign object.
- 12.** Wear hearing protection.
- 13.** Wear eye protection to prevent debris from getting into your eyes.

SAFETY

WARNING! NEVER operate the mower unless the discharge guard and either the deflector assembly or the vacuum collector adapter are fastened securely in place.

WARNING! Do not work around the mower deck boot or the blower area until you are certain that the mower blades and the blower impeller have stopped rotating.

WARNING! To avoid serious injury, perform maintenance on the vacuum collector; **ONLY AFTER STOPPING THE MOWER'S ENGINE AND WAITING FOR ALL MOVING PARTS TO COME TO A COMPLETE STOP.** Set the parking brake. Always remove the ignition key before beginning maintenance.

WARNING! For your own personal safety, **ALWAYS mow ACROSS the face of slopes and NEVER UP and DOWN the face. NEVER attempt to mow excessively steep slopes, and use caution when turning on any slope.**

Safety Alert Symbol



This Safety Alert Symbol means: **“ATTENTION! BECOME ALERT! YOUR SAFETY IS INVOLVED!”**

This symbol is used to call attention to safety precautions that should be followed by the operator to avoid accidents. When you see this symbol, carefully read the message that follows and heed its advice. Failure to comply with safety precautions could result in death or serious bodily injury.

Safety Signs

The signal words **DANGER**, **WARNING**, and **CAUTION** are used on the equipment safety signs. These words are intended to alert the viewer to the existence and the degree of hazard seriousness.



White letters on **RED**

This signal word indicates a potentially hazardous situation which, if not avoided, will result in death or serious injury.



Black letters on **ORANGE**

This signal word indicates a potentially hazardous situation which, if not avoided, could result in death or serious injury.

It may also be used to alert against unsafe practices.



Black letters on **YELLOW**

This signal word indicates a potentially hazardous situation which, if not avoided, will result in minor or moderate injury.

It may also be used to alert against unsafe practices.

Section I - INTRODUCTION AND DESCRIPTION

Introduction

We are pleased to have you as a PECO customer. Your collection system has been designed to give you a low maintenance, simple, and effective way to collect the grass clippings from your mower. The manuals are provided to give you the necessary instructions to properly mount, operate and maintain the collection system on your mower. Please read this manual thoroughly. Understand what each control is for and how to use it. Observe all safety decal precautions on the machine and noted throughout the manual.

NOTE: all references made to right, left, front, rear, top or bottom are as viewed from the normal operator's position on the mower.

Description

The grass collection system is designed for turf maintenance where there is a need to collect the grass clippings as the mower cuts the turf. It is also used for picking up leaves and in pre-season and post-season clean-up. The blower, mounted on the right side of the unit, uses a belt and gearbox system from the engine PTO shaft. Drive train protection comes through belt slippage. The blower draws grass clippings from the discharge area of the cutting deck back to the collection bags mounted at the rear portion of the mower frame. The operator can engage the blower with a push of the over-center linkage on the right side of the unit. Once the bags are full with clippings, they can be released to make for easy dumping.



Unit Model #: 28120903

Mower: Kubota

Owner's Manual: Q0597

Mower Type: Z200

Deck Size: 48" & 54"

Vac Type: P2B+ (9 Cu. Ft.)

Deck Type:

Drive Type: PTO-R Drive

Revision #: 0

Fits Year(s): 2023 - Newer



A2031 Baffle Kit

- (1) B0928 FRNT BAFFLE PLATE
- (1) B0929 FRNT BAFFLE PLATE 2
- (1) HB0654 BAFFLE KIT HW BAG

A2025 Boot Kit

- (1) V0048 BOOT
- (1) B0906 BOOT PLATE
- (1) B0910 BOOT PLATE FASTENER
- (1) HB0648 BOOT KIT HW BAG

A2030 Weight Kit

- (1) HB0653 WEIGHT KIT HW BAG
- (1) B2257 WEIGHT BRACKET
- (1) B0704 14" WEIGHT BAR

A2428 Mount Kit

- (1) B2252 Top / Left Mnt Plate
- (1) B2253 Top / Right Mnt Plate
- (1) B2255 Left PTO Mnt Plate
- (1) B2256 Right PTO Mnt Plate
- (1) B2254 Lower / Right Mnt Plate
- (1) HB0878 HW Bag Mount Kit
- (1) HB0649 HW Bag Safety Interlock Kit
- (1) HB0879 Eng Pulley Bushing Kit
- (1) B0939 Lower Mount Tube / 27"
- (2) G0002 3.3 Cu. Ft. Collection Bags
- (4) J0060 6" Hose Clamps
- (1) V0016 6" Blower Cone
- (1) F0060-18 6" x 18" Upper Hose
- (1) B0733 PTO Stop Plate
- (1) F0060-36 6" x 36" Upper Hose
- (1) A2194_01 PTO-R Drive Assy

A1842_01 PTO-R Handle & Belt Guard

- (1) HB0874 BELT GUARD HW BAG
- (1) A1137_01 PTO-R HANDLE EXT KIT
- (1) B0681 PULLEY GUARD / LARGE

A2168 Vac Kit

- (1) A2101 Top Assy.
- (1) A2047 Upper Frame Assy.
- (2) B0227 Bag Ring
- (1) V0025 6" & 7" Plastic Inlet
- (1) Hb0683 Vac Kit HW Bag

SECTION III OPERATING INSTRUCTIONS

General Safety

Only qualified people familiar with this operator's manual and the mower's operator's manual should operate this machine.

Operation And Tips On Mowing

- A. Perform BEFORE EACH USE the maintenance list referenced in Section IV.
- B. Start mower.
- C. With the mower at high idle speed, engage the mower deck.
- D. While seated in the operator's seat, move Bagger PTO switch to the on position. With the PTO assembly engaged, you can proceed to operate the control levers of the mower.

NOTE: If the collection system does not appear to be collecting the grass clippings, disengage the deck and PTO assembly, then, engage the parking brake and turn the mower off. Check upper and lower hoses for any clogs.

To obtain the maximum effectiveness from your collection system, the tips listed below should be followed:

- * Watch your speed- Normal conditions will allow a speed of up to approximately 4 mph, but thick, heavy damp conditions will require reduced ground speed.
- * Mow with sharp blades- A sharp blade cuts cleaner.
- * Wet grass and leaves will decrease effectiveness and will increase horsepower requirements.
- * Mow at higher cutting heights- Remove and mulch no more than 2" of grass length with each mowing. (Experts recommend not cutting off more than 1/3 of the grass blade length at any given time.)
- * Mow twice, at different height settings, (high, then low), if grass is extra tall.
- * Remember that horsepower requirements will vary with the mowing conditions such as type and height of turf grass, moisture content, amount of leaves, whether the terrain is flat or hilly, etc.

Disengagement Of The PTO Assembly

- A. To disengage the PTO assembly, move Bagger PTO switch to the off position.

WARNING: The PTO assembly blades will continue to spin. DO NOT TOUCH the PTO assembly, pulleys, or the belt until the tractor is turned off. DO NOT adjust the belt tension until the mower is turned off. Refer to the Belt Installation section of the manual.

Unloading The Collection System

NOTE: To determine when the collection bags are full, follow the following steps:

- A. Stop the forward movement of the mower.
- B. Disengage the mower deck.
- C. Disengage the PTO assembly.
- D. Engage the parking brake.
- E. Once the parking brake has been engaged, then and only then, walk behind the mower and check the collection bags by first unhooking the rubber strap with S-hook that secures the plastic top, then lift the plastic hood. Load in bags should not exceed the height of the installed bag.
- F. To remove the bags from the frame, slide bags out and turn bags over to deposit clippings.
- G. Slide empty bags back onto the frame and secure plastic top with the rubber strap with S-hook.

NOTE: Do not allow collection bags to become over-filled as potential damage may occur to your equipment. Also, be sure to clean the hood screen as needed.

SECTION IV MAINTENANCE

Maintenance Checklist

Before each use:

1. Check blades and spindles to be sure that no foreign objects, such as wire or steel strapping bands, are wrapped around them.
2. Inspect blades for wear. Replace if necessary. If it is necessary to sharpen the blades, remove the blades from the spindles before sharpening. DO NOT sharpen blades while still attached to the mower.

3. Make sure all shields are in place and in good condition. Repair or replace any missing or damaged shields.
4. Perform lubrication per instructions.
5. Listen for abnormal sounds, which might indicate loose parts, damaged bearings, or other damage. Correct any deficiency before continuing operation.
6. With the engine off, engage the blower assembly. Check the belt tension and inspect the pulley belt for cracks or tears.
7. Check for wear or deterioration of the upper or lower hoses. If there are any portions of the hose that have been torn or worn through, replace immediately.

After Each Use:

1. Clean all debris from machine especially from the container, underneath the belt shields, and safety decals. Replace any missing or illegible decals.
2. Inspect the unit for worn or damaged components. Repair or replace before the next use. Any replacement component installed during repair shall include the component's current safety decal specified by the manufacturers to be affixed to the component.
3. Under normal usage, the bag material is subject to deterioration and wear and should therefore be frequently checked for necessary replacement. Any replacement bag should be checked to ensure compliance with the original manufacturer's recommendations or specifications.
4. Check belt for proper tension.

Lubrication

Gearbox:

NOTE: The gearbox is filled with 6.0 oz. of Mobilube HD Plus 80W-90 oil and permanently sealed. There is no need for scheduled lubrication. The oil level should only be checked if a leak is observed or if a change in gearbox noise is noticed.

Operators are recommended to check for leaks weekly. If a leak is observed, both the gasket and the seals are recommended to be replaced.

Replace the oil using 5.5 oz. of the recommended Mobilube HD Plus 80W-90 oil. Be sure to not overfill.

Blower Assembly:

NOTE: The following is for older PTO models that contain a greaseable zirc fitting. Newer models contain maintenance-free bearings and are without a greasable fitting.

1. On initial use: Grease the fitting on the blower shaft.
2. Every 25 hours of use: Re-grease the grease fitting.

NOTE: Use only white lithium based grease for lubrication of the shaft on the blower assembly.

SECTION V - PARTS & SERVICE

Parts And Service Information

Collection system owners should record the name and telephone number of their Service Center. Your Service Center will be happy to supply replacement parts, accessories, and do any service or repairs to your collection system. If for any reason your Service Center is unable to service your collection system or supply replacement parts, contact New PECO, Inc. and include the following information on the chart below.

DOCUMENT THE FOLLOWING INFORMATION FOR FUTURE REFERENCE

Unit Model Number: _____

Unit Engine Size: _____

Unit Serial Number: _____

Date of purchase: _____ / _____ / _____

Dealer/Distributor Name: _____

Address: _____ **State:** _____ **Zip:** _____

Phone Number: _____

New PECO, Inc.

10 Walden Dr | Arden, North Carolina 28704

Phone: 1-800-438-5823 | 828-684-1234

Fax: 828-684-0858

Email: peco@lawnvac.com

Website: www.lawnvac.com

TORQUE SPECIFICATIONS

Proper torque for American fasteners used on Peco equipment.
Recommended Torque in Foot Pounds (Newton Meters).*

AMERICAN Bolt Head Markings



SAE Grade 2
(No Dashes)

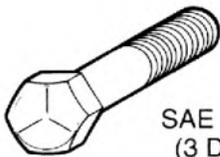

SAE Grade 5
(3 Dashes)

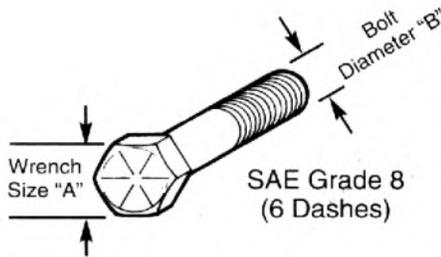

SAE Grade 8
(6 Dashes)

WRENCH SIZE (IN.) "A"	BOLT DIAMETER (IN.) "B" AND THREAD SIZE	SAE GRADE 2	SAE GRADE 5	SAE GRADE 8
7/16	1/4 - 20 UNC	6 (7)	8 (11)	12 (16)
7/16	1/4 - 28 UNF	6 (8)	10 (13)	14 (18)
1/2	5/16 - 18 UNC	11 (15)	17 (23)	25 (33)
1/2	5/16 - 24 UNF	13 (17)	19 (26)	27 (37)
9/16	3/8 - 16 UNC	20 (27)	31 (42)	44 (60)
9/16	3/8 - 24 UNF	23 (31)	35 (47)	49 (66)
5/8	7/16 - 14 UNC	32 (43)	49 (66)	70 (95)
5/8	7/16 - 20 UNF	36 (49)	55 (75)	78 (106)
3/4	1/2 - 13 UNC	49 (66)	76 (103)	106 (144)
3/4	1/2 - 20 UNF	55 (75)	85 (115)	120 (163)
7/8	9/16 - 12 UNC	70 (95)	109 (148)	153 (207)
7/8	9/16 - 18 UNF	79 (107)	122 (165)	172 (233)
15/16	5/8 - 11 UNC	97 (131)	150 (203)	212 (287)
15/16	5/8 - 18 UNF	110 (149)	170 (230)	240 (325)
1-1/8	3/4 - 10 UNC	144 (195)	266 (360)	376 (509)
1-1/8	3/4 - 16 UNF	192 (260)	297 (402)	420 (569)
1-5/16	7/8 - 9 UNC	166 (225)	430 (583)	606 (821)
1-5/16	7/8 - 14 UNF	184 (249)	474 (642)	668 (905)
1-1/2	1 - 8 UNC	250 (339)	644 (873)	909 (1232)
1-1/2	1 - 12 UNF	274 (371)	705 (955)	995 (1348)
1-1/2	1 - 14 UNF	280 (379)	721 (977)	1019 (1381)
1-11/16	1-1/8 - 7 UNC	354 (480)	795 (1077)	1288(1745)
1-11/16	1-1/8 - 12 UNF	397 (538)	890 (1206)	1444 (1957)
1-7/8	1-1/4 - 7 UNC	500 (678)	1120 (1518)	1817 (2462)
1-7/8	1-1/4 - 12 UNF	553 (749)	1241 (1682)	2013 (2728)
2-1/16	1-3/8 - 6 UNC	655 (887)	1470 (1992)	2382 (3228)
2-1/16	1-3/8 - 12 UNF	746 (1011)	1672 (2266)	2712 (3675)
2-1/4	1-1/2 - 6 UNC	870 (1179)	1950 (2642)	3161 (4283)
2-1/4	1-1/2 - 12 UNF	979 (1327)	2194 (2973)	3557 (4820)

METRIC

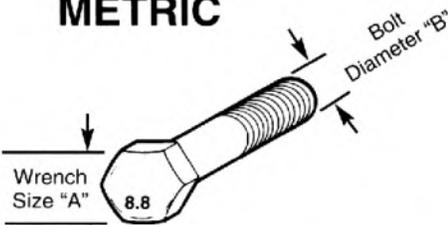

Numbers appearing on bolt heads indicate ASTM class.

Proper torque for metric fasteners used on Peco equipment.
Recommended torque in foot pounds (newton Meters).*

WRENCH SIZE (mm) "A"	BOLT DIA. (mm) "B"	ASTM 4.6	ASTM 8.8	ASTM 9.8	ASTM 10.9
8	5	1.8 (2.4)		5.1 (6.9)	6.5 (8.8)
10	6	3 (4)		8.7 (12)	11.1 (15)
13	8	7.3 (10)		21.1 (29)	27 (37)
16	10	14.5 (20)		42 (57)	53 (72)
18	12	25 (34)	74 (100)	73 (99)	93 (126)
21	14	40 (54)	118 (160)	116 (157)	148 (201)
24	16	62 (84)	167 (226)	181 (245)	230 (312)
30	20	122 (165)	325 (440)		449 (608)
33	22		443 (600)		611 (828)
36	24	211 (286)	563 (763)		778 (1054)
41	27		821 (1112)		1138 (1542)
46	30	418 (566)	1119 (1516)		1547 (2096)

*Use 75% of the specified torque value for plated fasteners. Use 85% of the specified torque values for lubricated fasteners.

Section V - INSTALLATION FOR USE

Recommended Tools & Equipment

For the installation of this Grass Collection Unit, It is recommended to always use Personal Protective Equipment, such as safety goggles & hearing protection, while using any tool or power equipment during the installation of your Grass Collection Unit.

A basic set of standard wrenches, sockets, and ratchets will be perfectly suitable for most operations outlined in this manual.

Preparation Of Mower

NOTE: The mower deck PTO belt must be removed from the electric clutch before continuing with the installation. Refer to your mower's owner's manual for instructions on PTO belt removal.

From the underside of the engine, disconnect the wiring harness attached to the electric clutch. Remove the bolt and electric clutch from the mower. Refer to Figure A.

Figure A

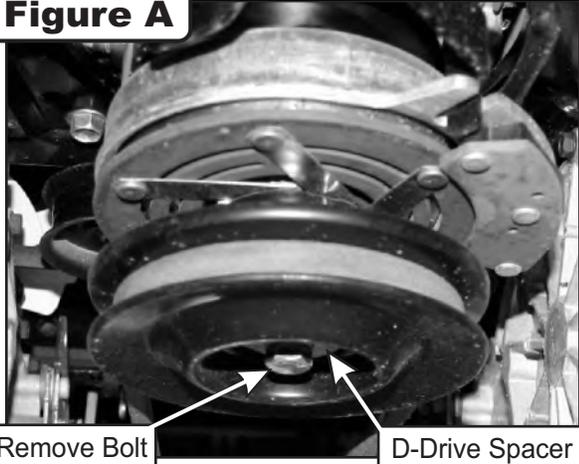

Upon removal of clutch determine if your mower is equipped with a D-drive spacer. If so, then proceed to Figure B. If your mower is equipped with bolt, fender and lock washer without D-drive spacer proceed to Figure C. Remove the D-drive spacer using an arbor press or equivalent. On removal, adjacent bearing OUTER race must be supported or bearing damage may occur. Refer to Figure B.

Figure B

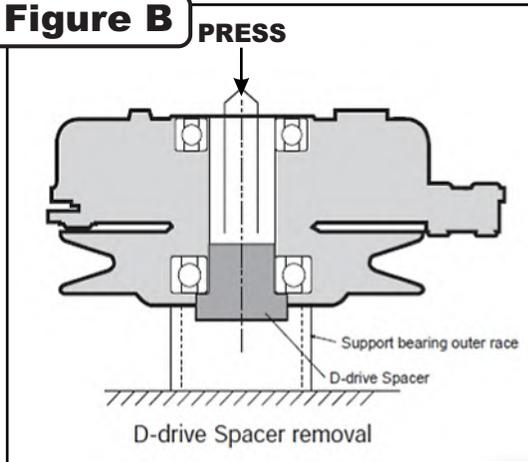
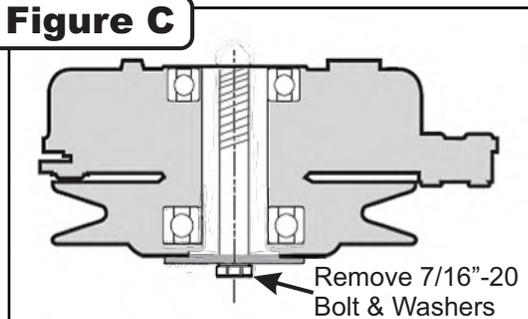
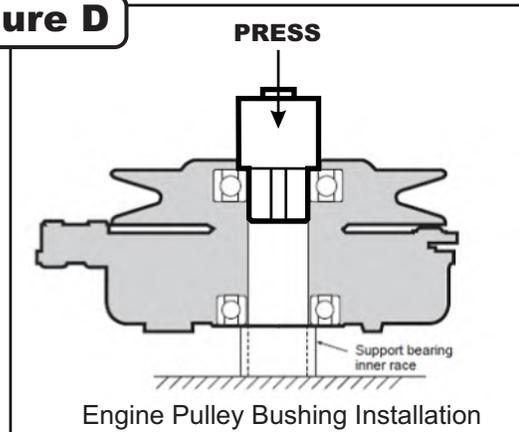

Figure C



The engine pulley assembly must be installed using an arbor press or equivalent. Before installation determine which Engine Pulley Bushing matches your clutch. During installation the opposite bearing inner race must be supported or bearing damage may occur. Refer to Figure D.

Figure D



Once the Engine Pulley Bushing is installed, reattach the clutch assembly & deck PTO belt to the mower and then review Figure E.

Figure E

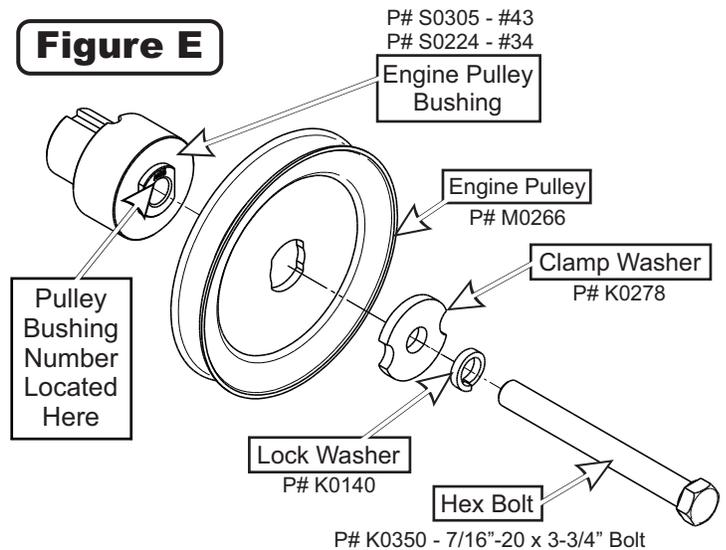

To assemble and fasten the Engine Pulley, align the Engine Pulley Bushing to the mower's clutch pulley and fasten using (1) Clamp Washer, (1) Lock Washer, and (1) Hex Bolt. **Torque the bolt to 55 ft./lbs.** The added pulley will power the collection system and should resemble Figure F when installed.

Figure F

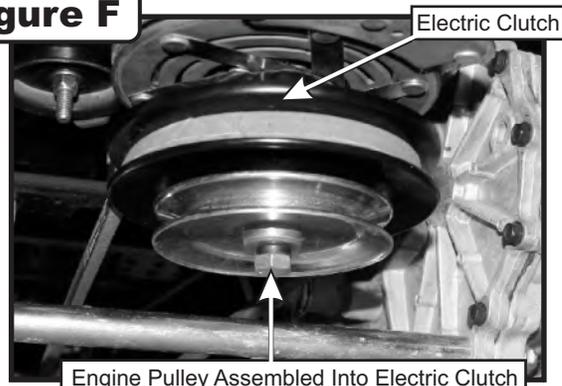

Preparation of Mower (continued)

An Exhaust Diverter will need to be installed on your mower to prevent the exhaust from damaging the PTO Assembly.

Attach (1) Exhaust Diverter (Item #1) to the engine exhaust pipe and secure the Exhaust Diverter using (1) Clamp Kit (Item #2). Refer to Figure A.

Position the diverter so that the exhaust blows to the rear at about a 45 - 60 degree angle so that it does not burn the Collection Bags or the ground. Refer to Figure B.

Figure A

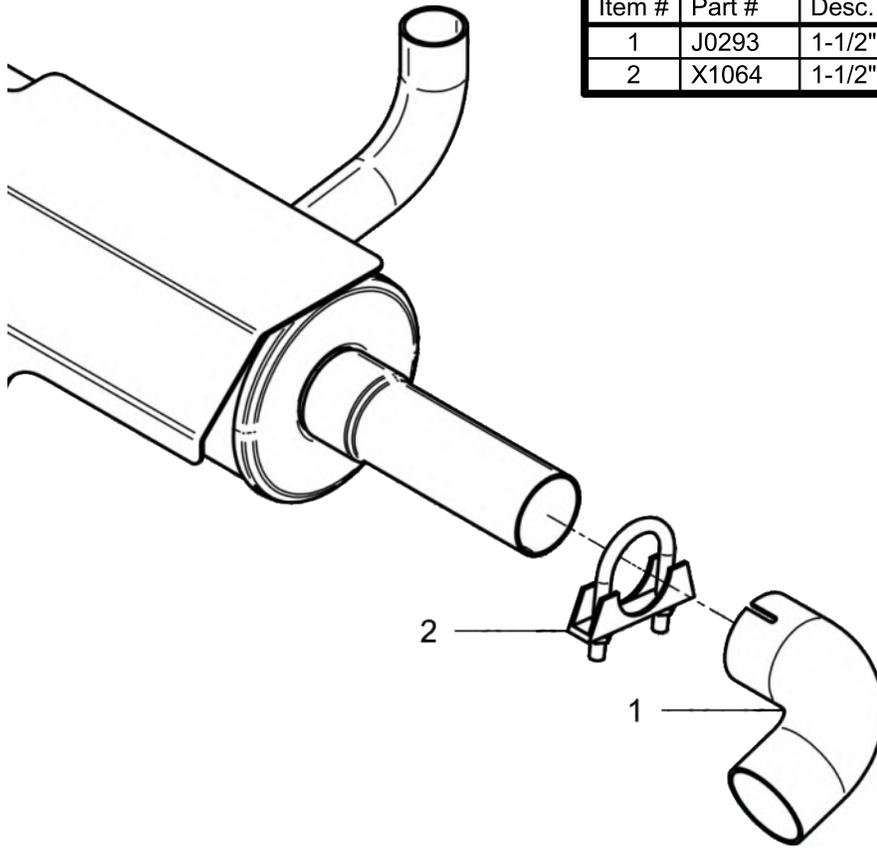

Item #	Part #	Desc.	Qty.
1	J0293	1-1/2" Exhaust Diverter	1
2	X1064	1-1/2" Exhaust Clamp Kit	1

Figure B

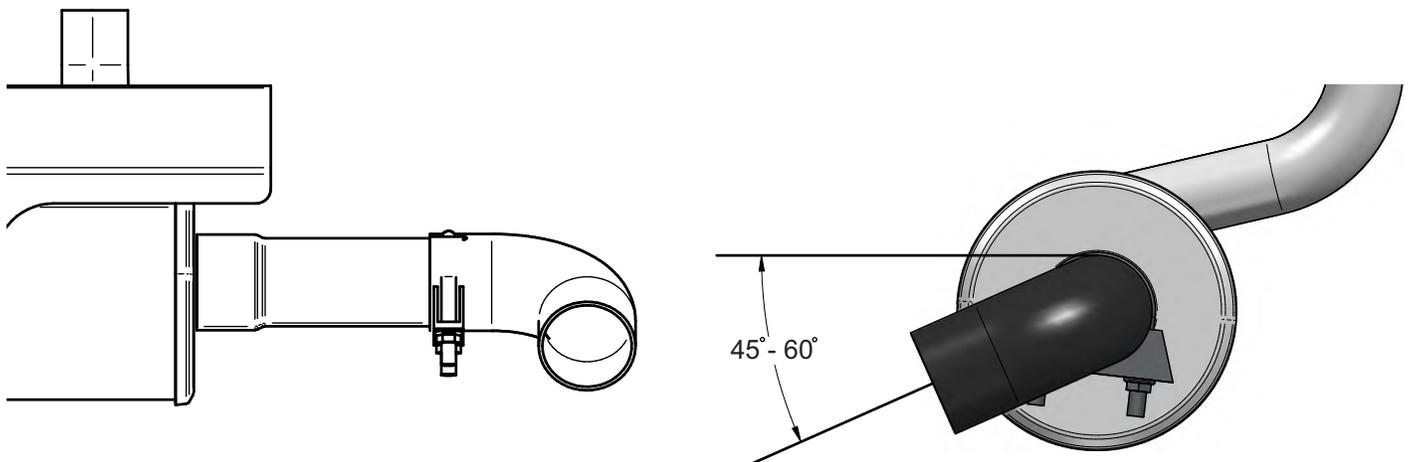

Rear Mount Plate Installation

Attach the Rear Mount Plate P#(B2251) to the rear of the mower using (2) 3/8-16 x 3-1/2" U-Bolts P#(K0407) and (4) 3/8"-16 Ny- Flange Locknuts P#(K2038).

Keep the hardware relatively loose for ease of installation.

Note: Some parts and part features have been removed from view for visual clarity.

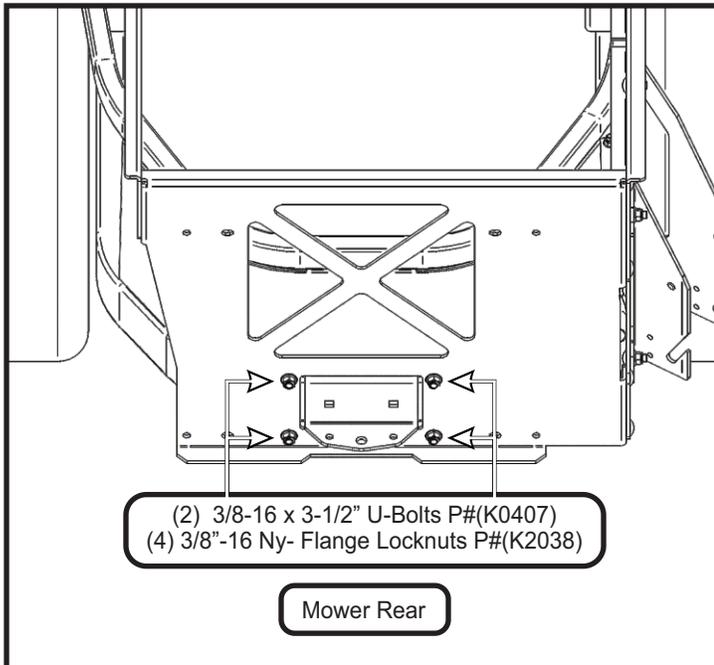

Lower Right Mount Plate Installation

First, before installing the Lower Right Mount Plate P#(B2254), loosely secure (1) 3/8"-16 x 1" Carriage Bolt P#(K1182) & (1) 3/8"-16 Ny-Flange Locknut P#(K2038) to the Bottom Right Mount Plate as shown in the figure. This step will help with the installation of the PTO Mount Plates (pg. 12) later.

Then, install the Lower Right Mount Plate to the lower right side of the mower by using the mower's preexisting hardware. Leave the hardware relatively loose.

Finally, secure the Lower Right Mount Plate to the Rear Mount Plate P#(B2251) by using (2) 3/8-16" x 1" Carriage Bolts P#(K1182) and (2) 3/8"-16 Ny-Flange Locknuts P#(K2038). Be sure the bolt head is oriented as shown in the figure for ease of installation.

Leave the hardware relatively loose.

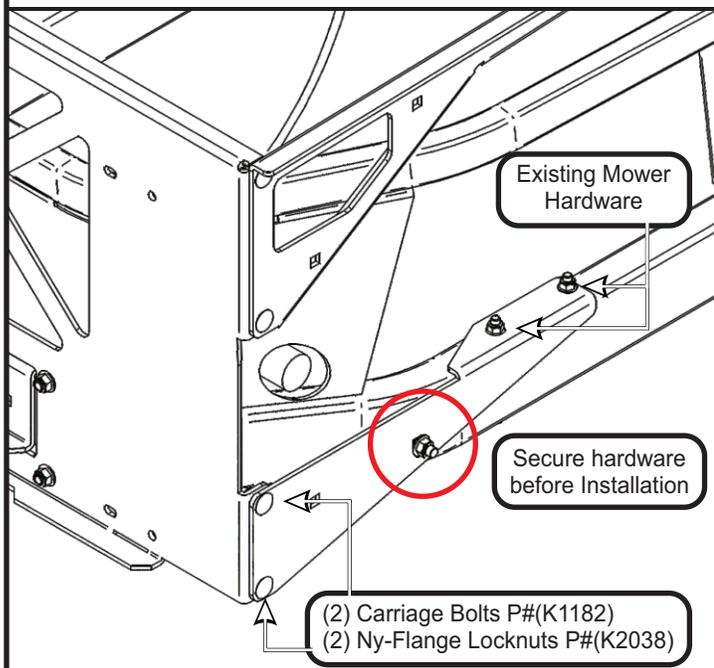

Top Mount Plates Installation

To Install the Left Top Mount Plate P#(B2252), position the Left Top Mount Plate between the ROPS and the Rear Mount Plate P#(B2251) as shown. Secure the Left Top Mount Plate to the ROPS by using (1) 3/8"-16 x 2-11/16" U-Bolt P#(K1119) and (2) 3/8"16 Ny-Flange Locknuts P#(K2038). Secure the Left Top Mount Plate to the Rear Mount Plate by using (2) 3/8-16" x 1" Carriage Bolts P#(K1182) and (2) 3/8"-16 Ny-Flange Locknuts P#(K2038). Leave the hardware relatively loose.

To install the Right Top Mount Plate P#(B2253), position the Right Top Mount Plate over the ROPS and the Rear Mount Plate as shown. Secure the Right Top Mount Plate to the ROPS by using (1) 3/8"-16 x 2-11/16" U-Bolt P#(K1119) and (2) 3/8"16 Ny-Flange Locknuts P#(K2038). Secure the Right Top Mount Plate to the Rear Mount Plate by using (2) 3/8-16" x 1" Carriage Bolts P#(K1182) and (2) 3/8"-16 Ny-Flange Locknuts P#(K2038). Leave the hardware relatively loose.

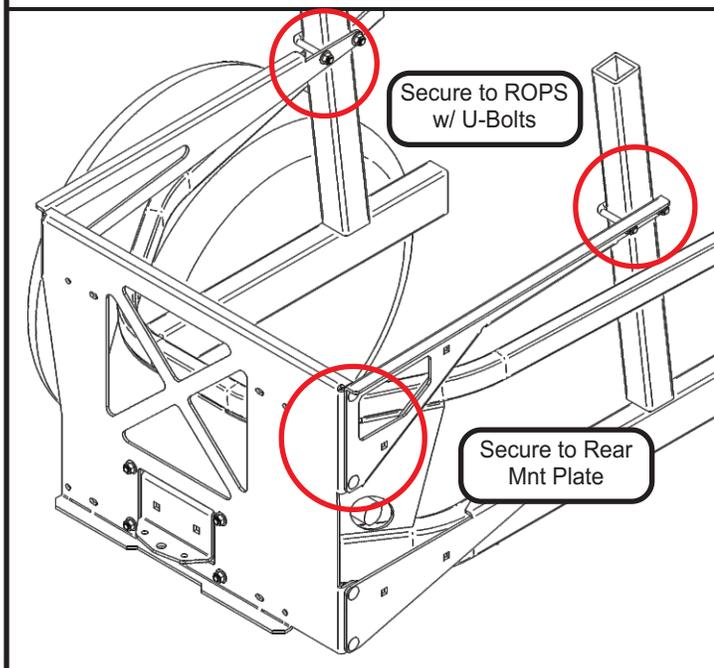

PTO Mount Plates Installation

First, install the Right PTO Mount Plate P#(B2256) to the Top & Lower Right Mount Plates by using the previously installed (1) 3/8-16" x 1" Carriage Bolt P#(K1182) and (1) 3/8"-16 Ny-Flange Locknut P#(K2038) along with another set of (1) 3/8-16" x 1" Carriage Bolt and (1) 3/8"-16 Ny-Flange Locknut. Be sure the bolt heads are oriented facing the mower for an easier installation.

Then, secure the Left PTO Mount Plate P#(B2255) to the Top & Lower Right Mount Plates by using (2) 3/8-16" x 1" Carriage Bolts P#(K1182) and (2) 3/8"-16 Ny-Flange Locknuts P#(K2038). Refer to Figure A.

Note: Some parts and part features have been hidden from view for visual clarity.

Figure A

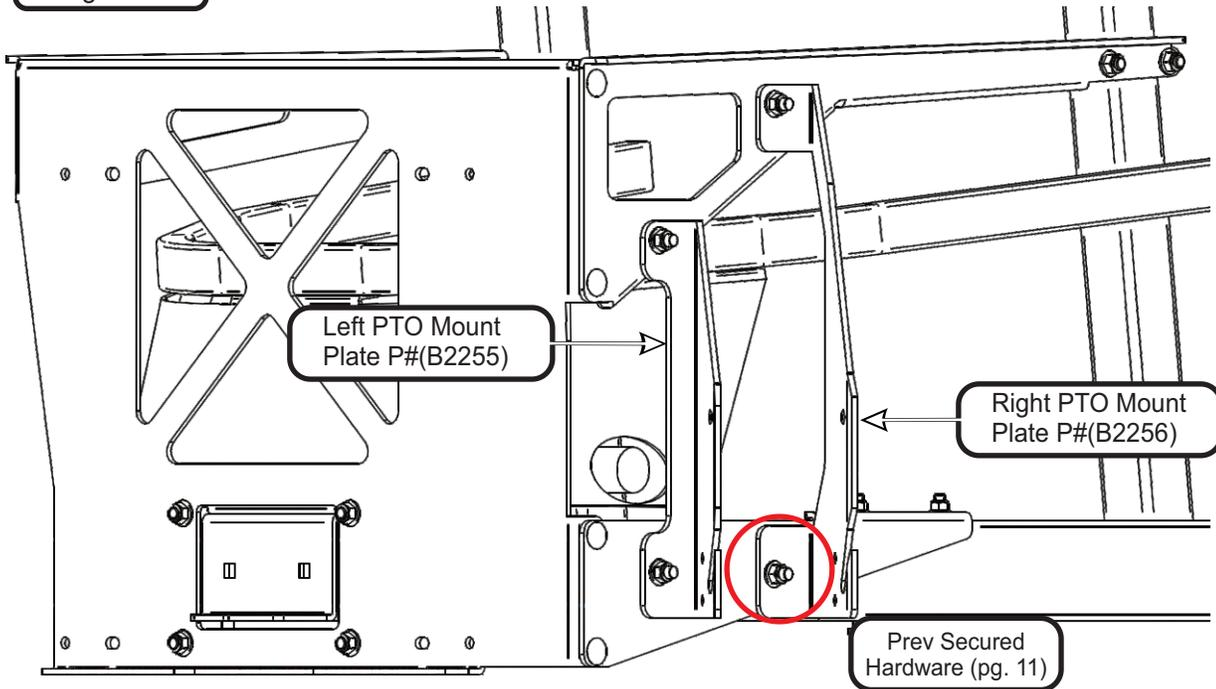

Finally, position the PTO Stop Plate P#(B0733) between the Left & Right PTO Mount Plates. Align all four of the Mount holes and secure the PTO Stop Plate by using (4) 1/4"-20 x 3/4" HHCS P#(K1222) and (4) 1/4"-20 Ny-Flange Locknuts P#(K2014). Refer to Figure B.

Tighten all hardware at this time.

Figure B

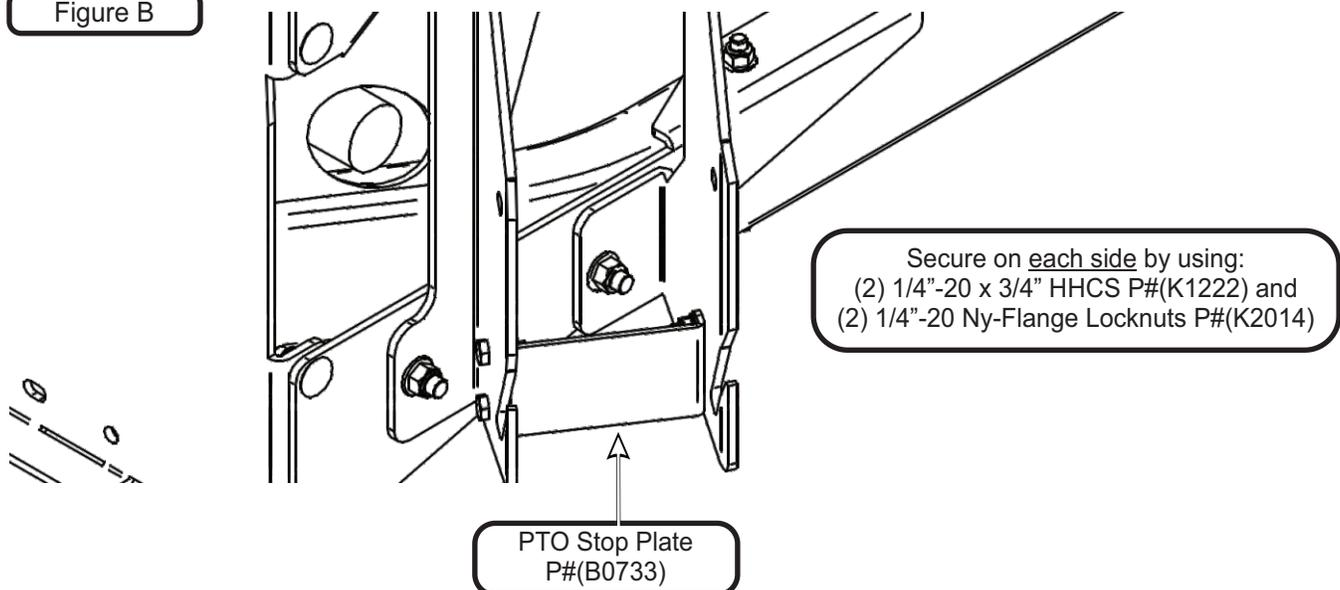

Lower Mount Tube Installation

Attach both Lower Mount Tubes P#(B0939) by using (2) 5/16"-18 x 2.5" U-Bolts P#(K1098) and (4) 5/16"-18 Ny-Flange Locknuts P#(K2516) PER Lower Mount Tube. Refer to Figure A.

Note: Some parts and part features have been hidden from view for visual clarity.

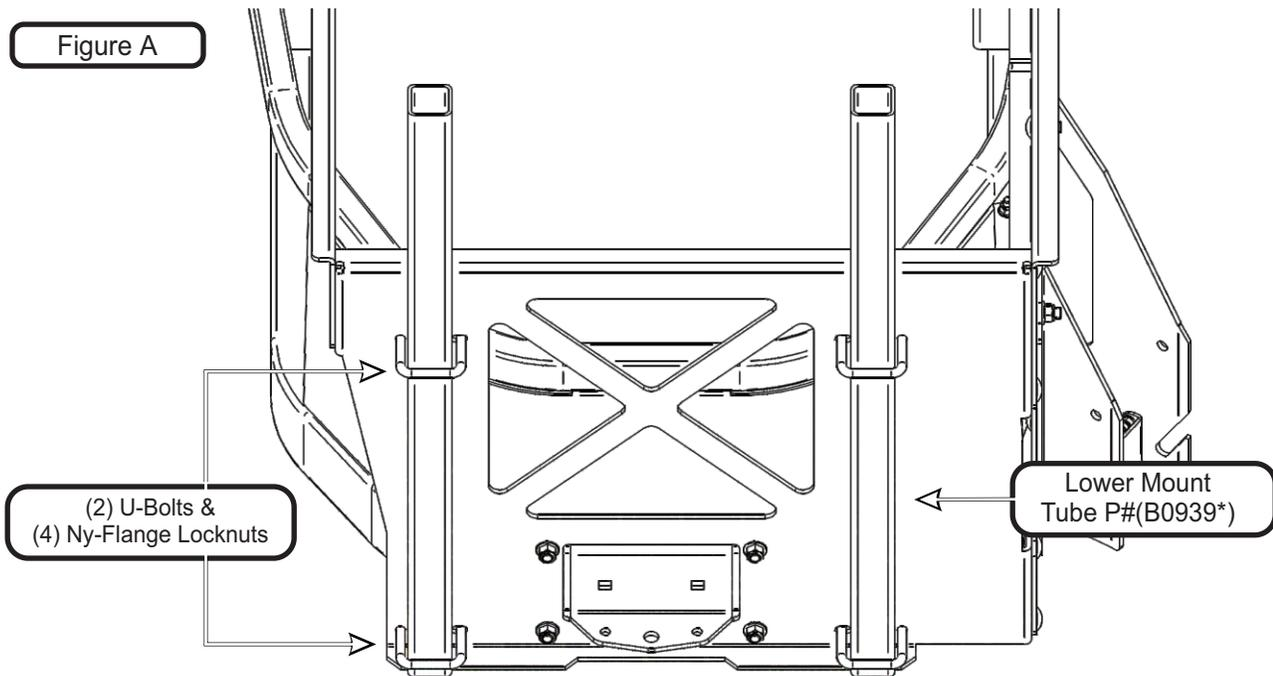

Upper Frame Assembly Installation

Position the Upper Frame Assembly P#(A2047) above the Lower Mount Tubes as shown in Figure B. Slide the Upper Frame Assembly down onto the Lower Mount Tubes and secure using (2) Clevis Pins P#(K0133) and (2) Hair Pin Clips P#(K0088).

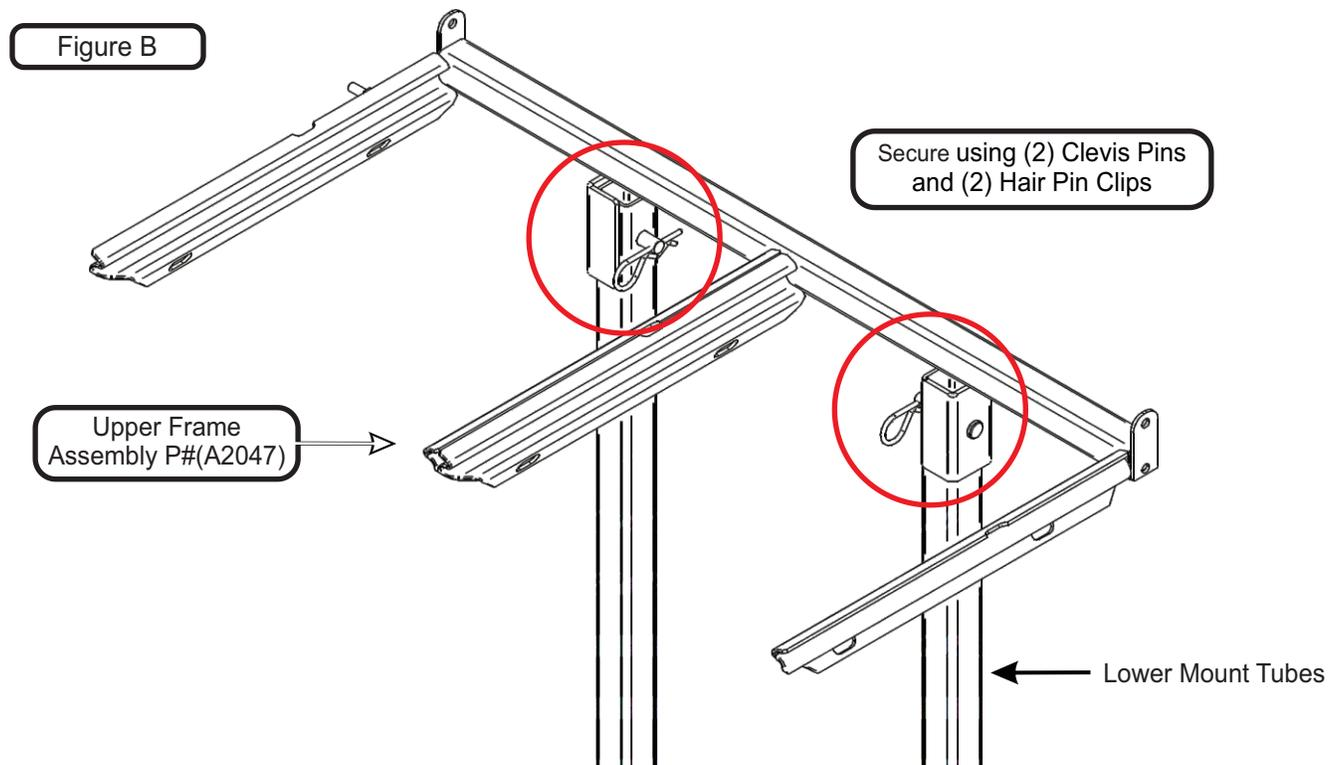

PTO Assembly Installation

Remove (3) 1/4"-20 x 1/2" HHSTS P#(K0353) from the PTO assembly to remove the belt guard. Insert the mount rod of the PTO assembly, into the mounting slots on the PTO mount plates, as shown in Figure A.

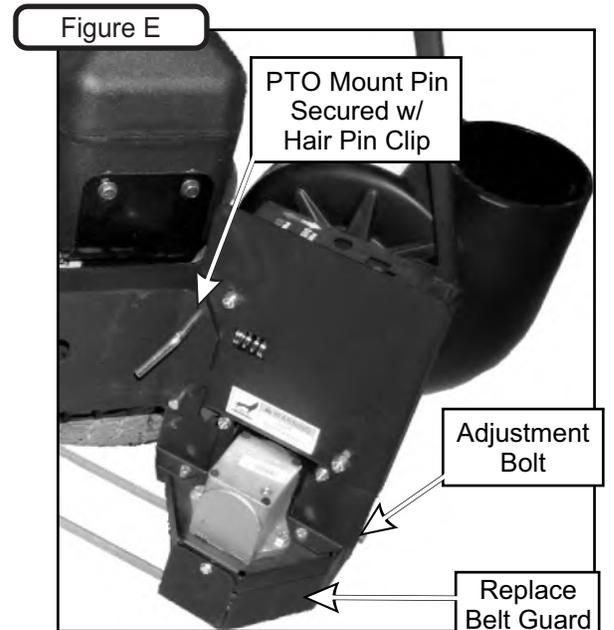
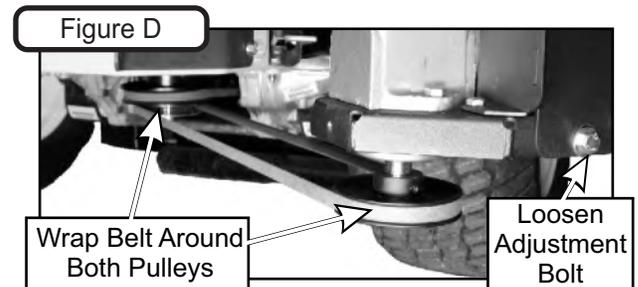
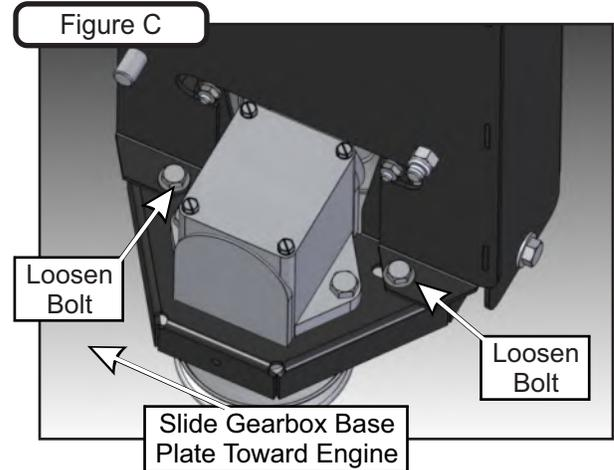
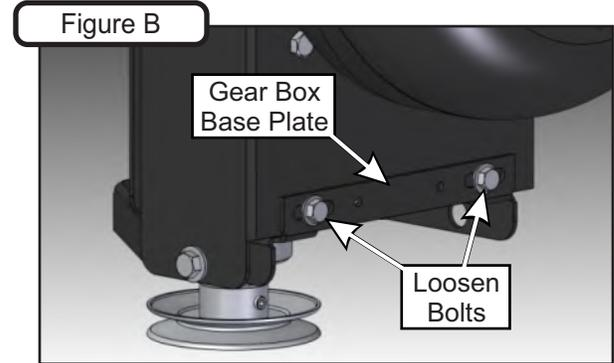
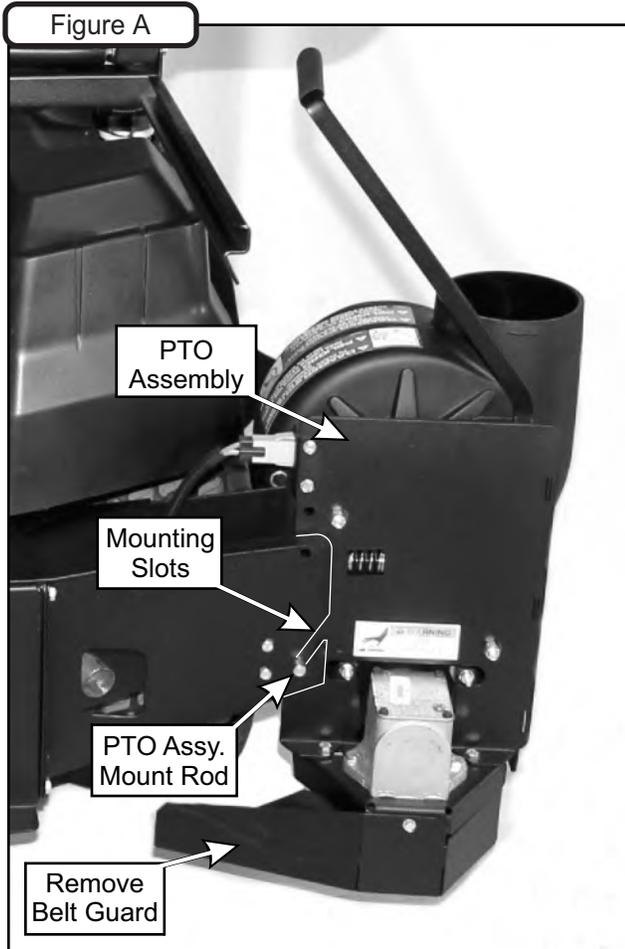

Belt Installation/Removal & Adjustment

Installation/Removal: Loosen the (4) 5/16"-18 x 3/4" HHCS P#(K1153) that secure the gear box base plate. Loosen the adjustment bolt (1) 3/8"-16 x 2" hex bolt P#(K0348). Slide the gearbox towards the mower until there is enough clearance for the kevlar belt to slide over both the engine and gearbox pulleys. Install the kevlar belt. Pivot PTO assembly to align holes, then fasten by inserting (1) PTO mount pin P#(B0274). Secure the mount pin using (1) hair pin clip P#(K0086). Refer to Figures B,C & D.

Adjustment: To adjust the belt tension, turn the adjustment bolt clockwise until there is 1" of deflection, with 10-11lbs of pressure applied to the center of the belt. When proper tension is achieved, tighten the (4) 5/16"-18 x 3/4" HHCS that secure the gear box base plate to the PTO assembly. Replace the belt guard and (3) 1/4"-20 x 1/2" HHSTS. Refer to Figure E.

Front Baffle Installation (48" Deck)

Front Baffle Installation (54" Deck)



CAUTION

To avoid personal injury:

- Disengage the PTO, stop the engine, remove the key and wait for all moving parts to stop
- Never operate the mower without a discharge cover or grass-catcher boot installed.

1. Remove the discharge cover by removing the cotter pin and slide the pin out.

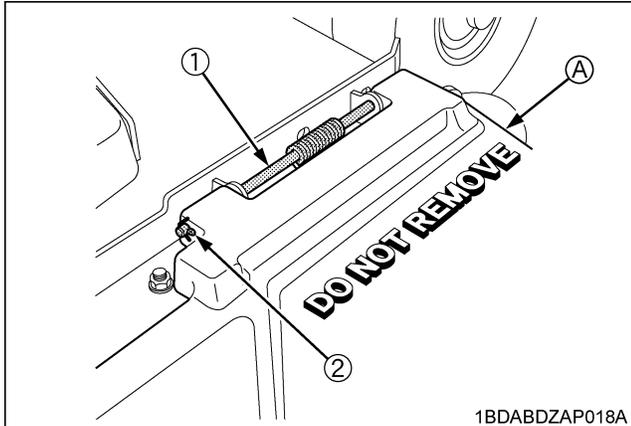

- (1) Discharge pin (A) Discharge cover
(2) Cotter pin

2. Acquire adequate access to the bottom of the mower deck by raising the mower deck to the "carry" position.

3. Install the Front Baffle Plate 2 using the (2) existing carriage bolts and Ny-Flange Locknuts.

Fully Tighten both fasteners.

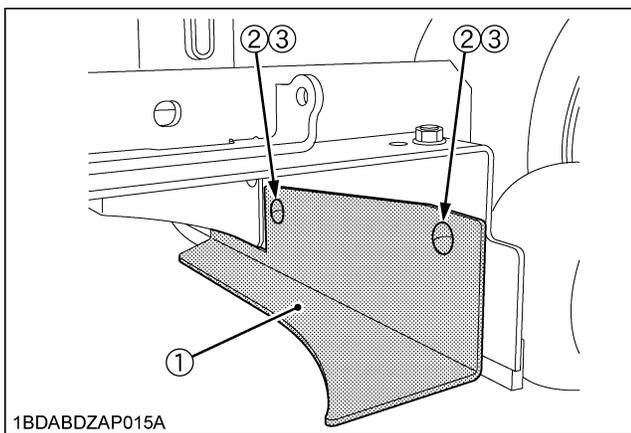

- (1) Front Baffle Plate 2 P#(B0929)
(2) M8 x 16 square neck bolt
(3) M8 Flange Lock Nut

1. Remove the discharge cover by removing the cotter pin and slide the pin out.

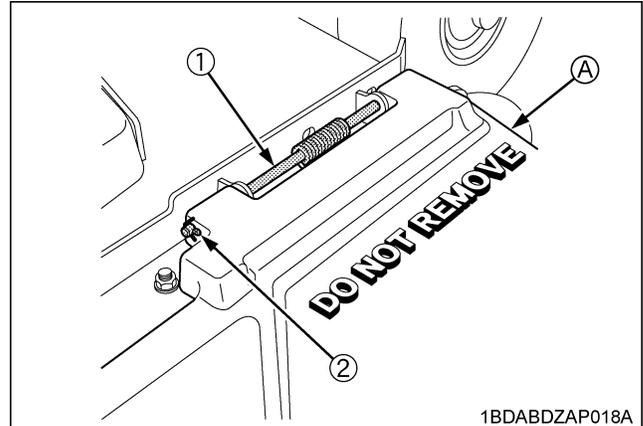

- (1) Discharge pin (A) Discharge cover
(2) Cotter pin

2. Fasten the 2 Front Baffle Plates together using (2) 5/16"-18 x 3/4" Carriage Bolts with (2) Ny-Flange Locknuts.

Fully tighten both fasteners.

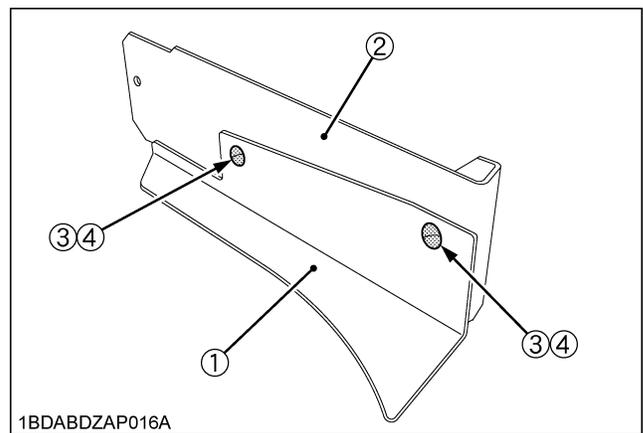

- (1) Front Baffle Plate 2 P#(B0929)
(2) Front Baffle Plate P#(B0928)
(3) Carriage Bolt 5/16"-18 x 3/4" P#(K1142)
(4) Ny-Flange Lock Nut 5/16"-18 P#(K2516)

3. Acquire adequate access to the bottom of the mower deck by raising the mower deck to the "carry" position.

4. Install the front baffle assembly using the existing 2-M8 x 16 square neck bolts with 2 - M8 flange nuts. Fully tighten both fasteners.

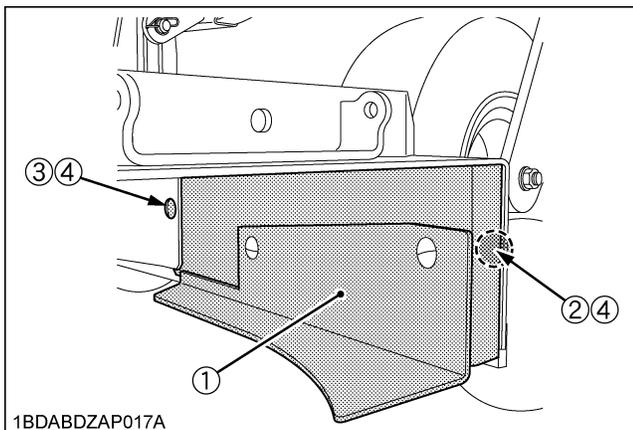

- (1) Front baffle assembly
- (2) M8 x 16 square neck bolt <19>
- (3) M8 x 20 square neck bolt <20>
- (4) M8 flange nut <24>

Safety Interlock Installation

Your PECO bagging system is equipped with a Safety Interlocking system designed to disengage the blower if the operator is not seated. The components to install the Safety Interlock are located in Hardware Bag P#(HB0649).

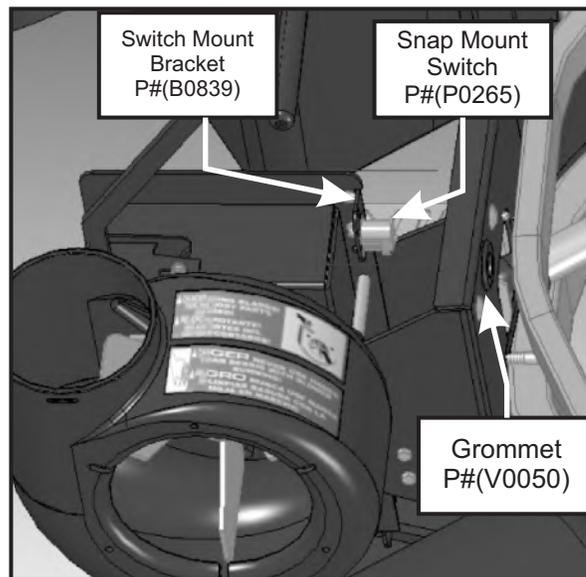
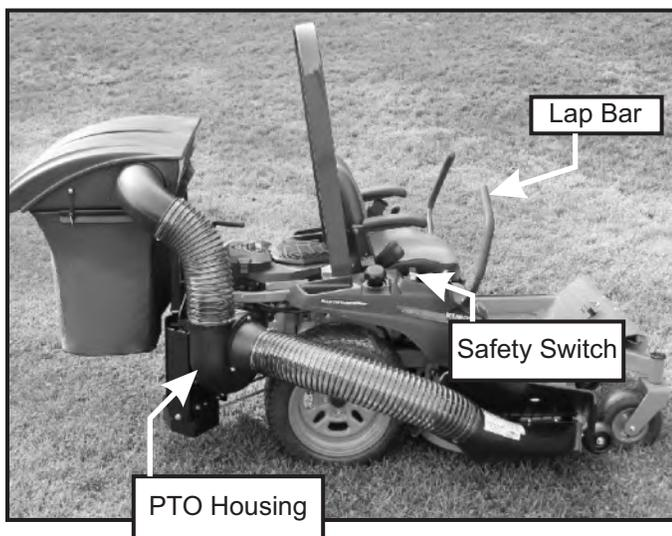

First, install Switch Mount Bracket P#(B0839) on the side of the PTO housing with Snap Mount Switch P#(P0265) inserted into slot using (2) 1/4"-20 x 5/8" Carriage Bolts P#(K1010) and (2) 1/4"-20 Ny-Flange locknuts P#(K2014). Next, insert Rubber Grommet P#(V0050) into hole located on the Right Mount Frame Plate.

Feed the Safety Interlock Harness P#(P0268) end with one connector through the grommet from the mower outward towards the PTO. Connect to switch. Next, carefully feed the harness around to the right side lap bar following the fuel line and through the rubber grommet used by the fuel line. Secure using the zip ties provided. Once through the fuel line grommet, feed the harness downward and to the right. Bring harness over the frame to avoid sagging.

Locate the safety switch that engages when the lap bar is in its outermost, neutral position. Unplug the connector from the bottom of the switch and plug the matching connector from the Harness to the switch. Then plug the two remaining ends together. Refer to the next page for further reference.



Fuel Line and Grommet

Wire Harness

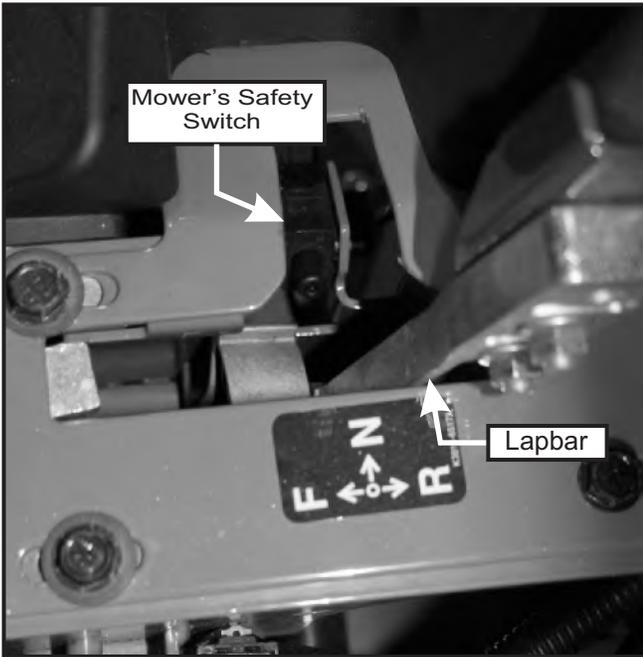

Mower's Safety Switch

Lapbar

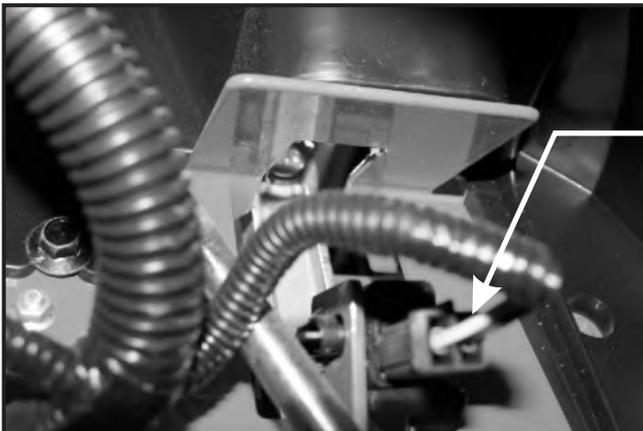

Disconnect Mower's Safety Switch here and connect Safety Interlock Harness Between.

Top Assembly To Upper Frame Assembly Installation

Align the Top Assembly Pivot Holes to the Upper Frame Assembly. See Figure A below. Before fastening, pull Rubber Dust Guard outward to seal against Upper Frame Assembly (towards the mower's operator seat). Fasten the Top Assembly to the Upper Frame Assembly using (2) 5/16"-18 x 2-1/2" HHCS P#(K0125) and (2) 5/16"-18 Ny-Flange Locknuts P#(K2516). Leave the Ny-Flange Locknuts slightly loose to allow the Top Assembly to open and close easily.

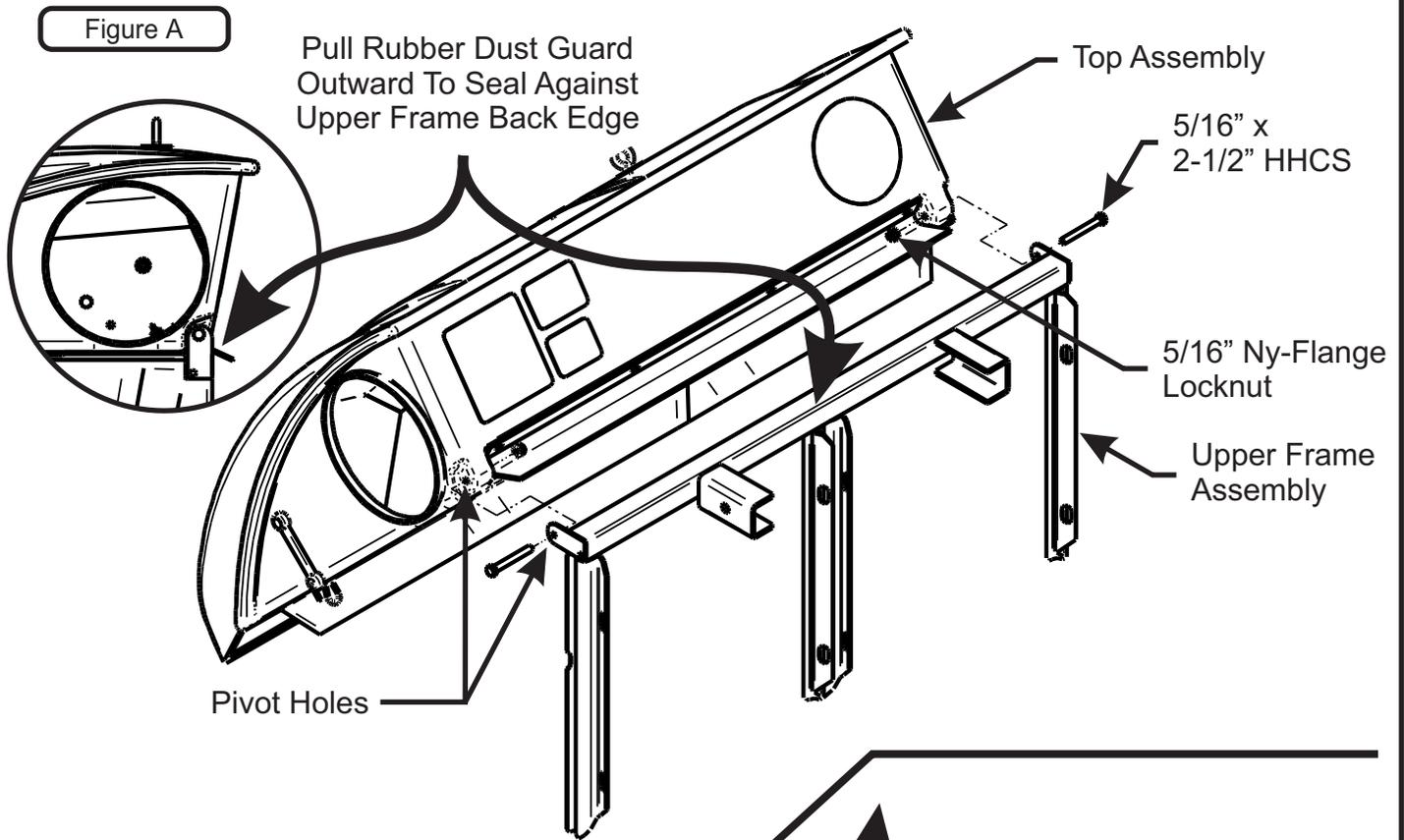

Inlet Installation

Position the Top Assembly on its side with the Inlet Hole facing up. See Figure B. 1: Insert the Inlet from inside the Top Assembly, up through the Inlet Hole, until the Inlet Retaining Lip meets the Inlet Hole. 2: Position the Inlet as shown in Figure B, then pull the Inlet until a portion of the Inlet Retaining Lip protrudes from the Inlet hole. 3: Next, lift the Inlet as shown in Figure B until all of the Inlet Retaining Lip protrudes from the Inlet Hole. Once installed, the Inlet should pivot freely about the Inlet Hole.

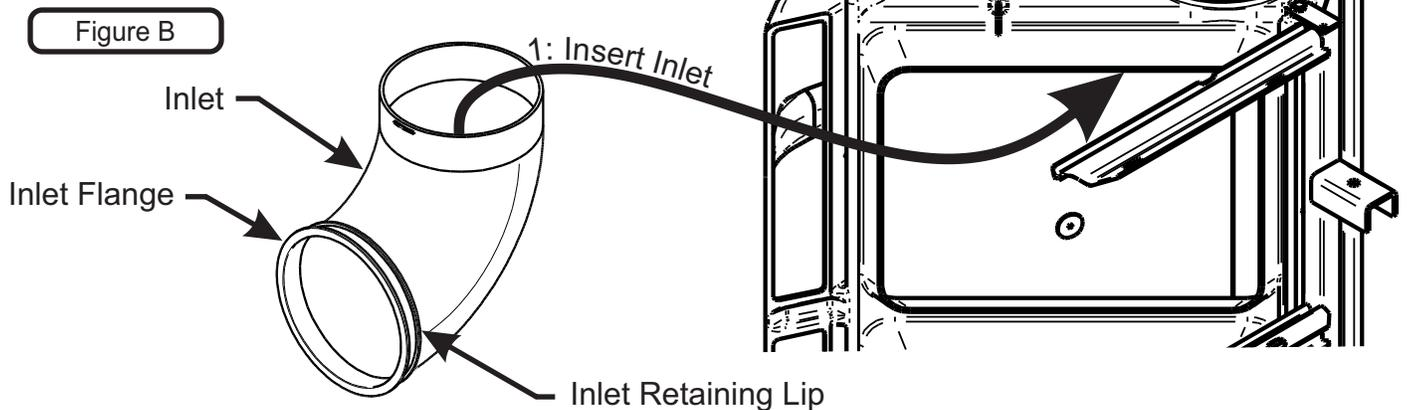

Hinge Kit Assembly Installation

Assemble the Hinge Kit using (1) Latch Plate P#(B0884), (1) 5/16"-18 x 1-1/4" HHCS P#(K1156), (1) 5/16"-18 Ny-Flange Lock Nut P#(K2516), (3) 5/16" Flat Washers P#(K0042), (1) Latch Spacer P#(S0006), (2) Extra Heavy 5/16" Fender Washers P#(K0505) and (1) 5/16"-18 Lock Nut P#(K0506). Leave the nuts loose enough to allow fluid movement of the top when opening and closing. When opened, the top should rest in the Latch Plate Slot.

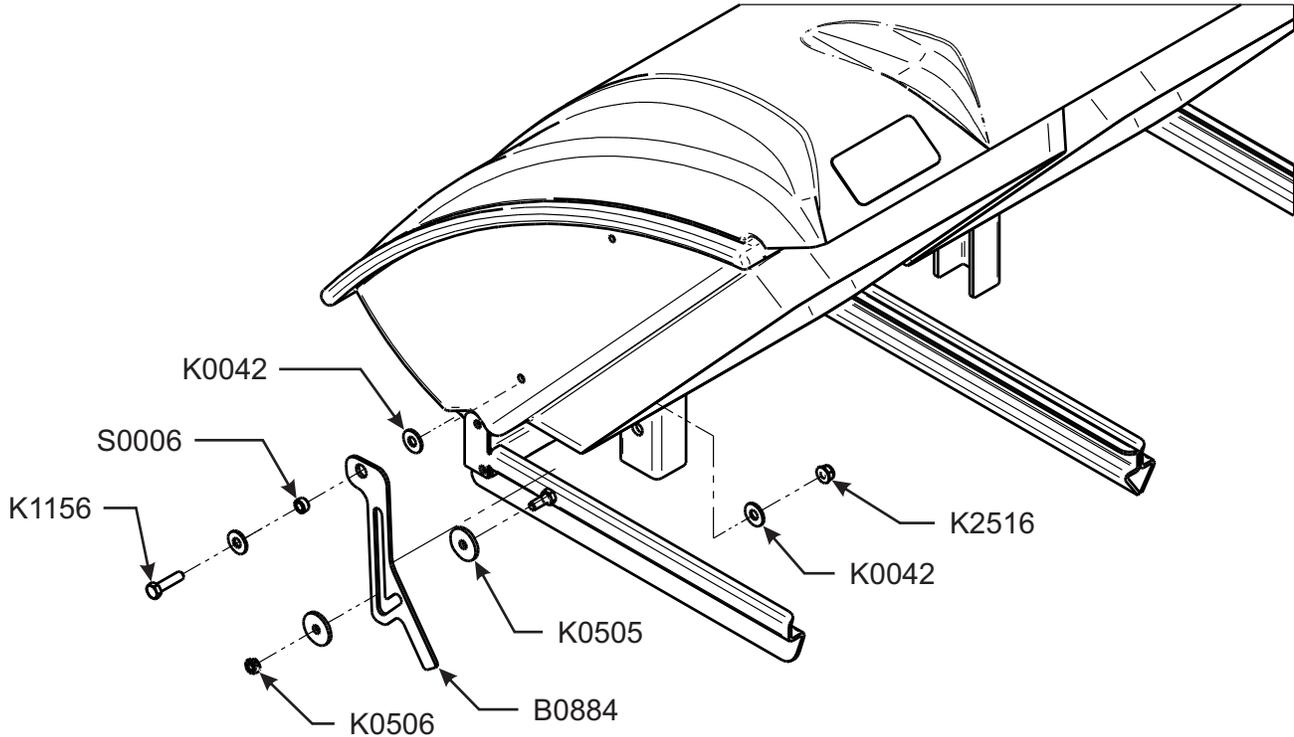

Even Bag Fill Adjustment

Flap can be adjusted Up/Down depending on mowing conditions. Adjust flap up to allow more dense material to reach left bag. Adjust flap down to allow less dense material to reach the right bag. Once adjusted properly, both bags should fill evenly, but may require further adjusting when mowing conditions change.

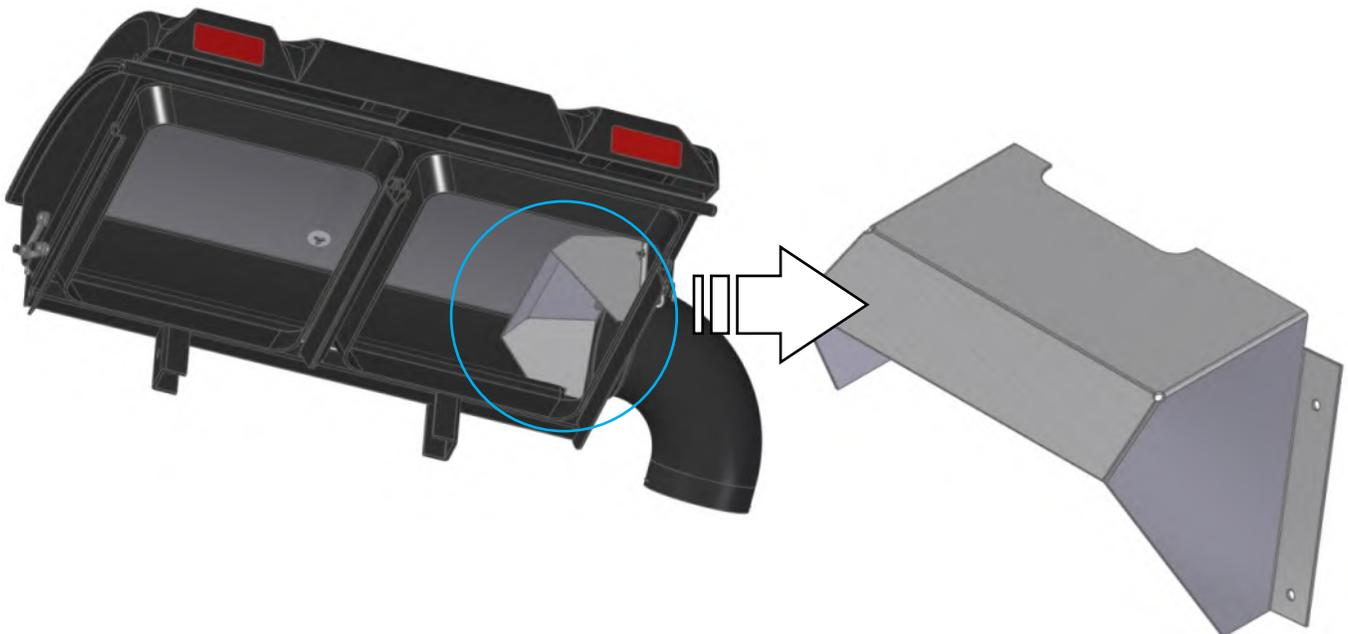

Bag Assembly

First, take one of the Bag Ring Split Ends and insert it through the Bag Seam Opening. Next, rotate the Bag around the Bag Ring (1) full turn (360 degrees) until the Bag Ring Split Ends and the Bag Seam Opening are positioned on the same side. Then, connect the Bag Ring Split Ends using (1) End Connector. Last, rotate the Bag Ring and the End Connector Assembly (1/2") turn (180 degrees) to position the Connector opposite of the Bag Seam Opening. Note Final End Connector Location below in Figure A. Repeat for each Bag.

Figure A

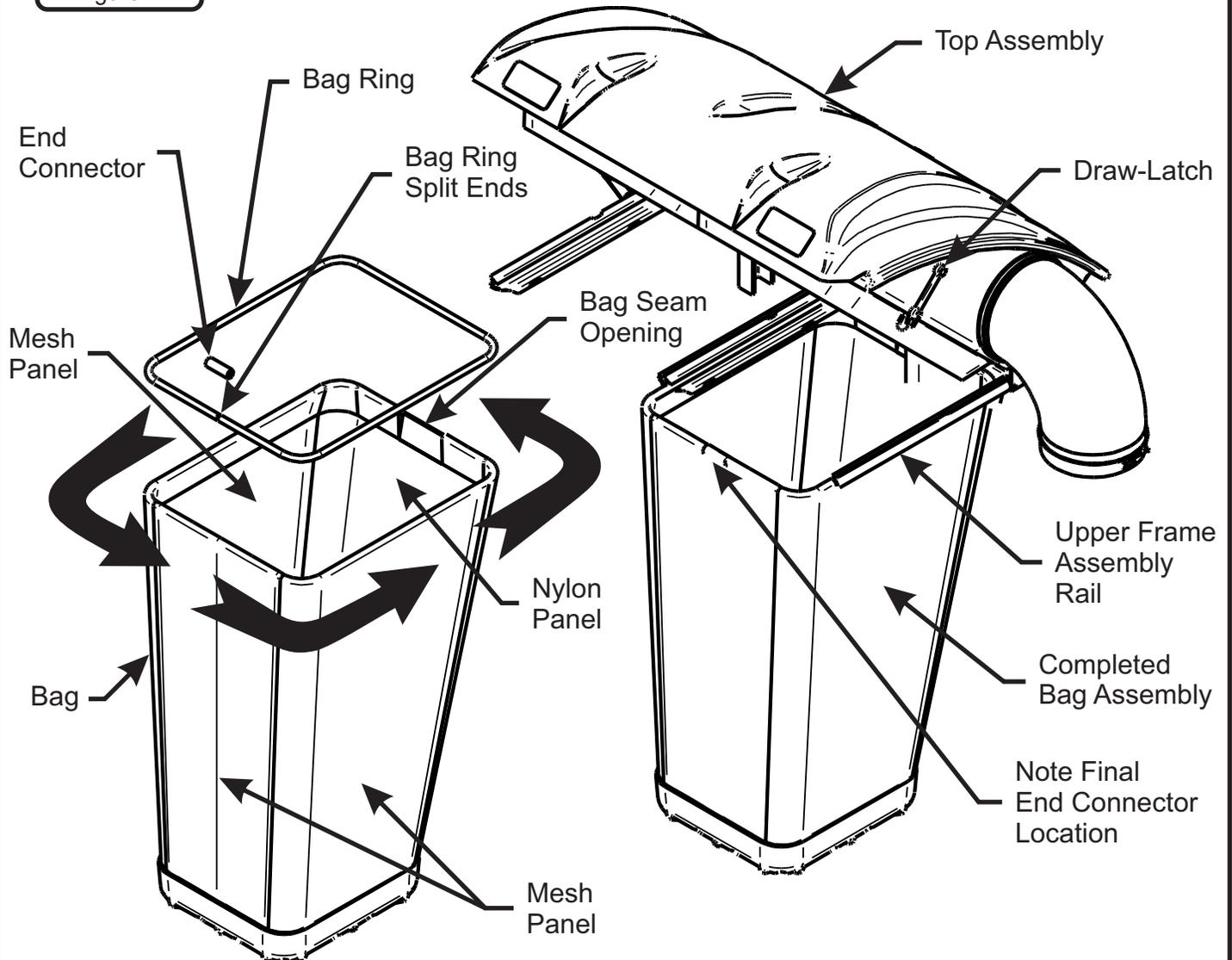

Bag Assembly Installation

Slide the Completed Bag Assembly into the Upper Frame Assembly Rails and close the Top Assembly. Fasten the Draw-Latch on either side to hold the bagger closed.

Blower Cone Installation

Align the bolt holes of the Blower Cone (Item#1) to the bolt holes located on the Blower Housing of the PTO Assembly. Secure the Blower Cone to the Blower Housing by using (3) 1/4"-20 x 3/4" HHCS (Item #4), (3) 1/4" Lock Washers (Item #3), and (3) 1/4" Flat Washers (Item #2).

Figure A

Item #	Part #	Desc.	Qty.
1	V0016	6" Plastic Blower Cone	1
2	K0037	Flat Washer / 1/4" (.75 OD x .312 ID x .060 T)	3
3	K0039	1/4" Lock Washer	3
4	K1222	1/4"-20 X 3/4" HHCS	3

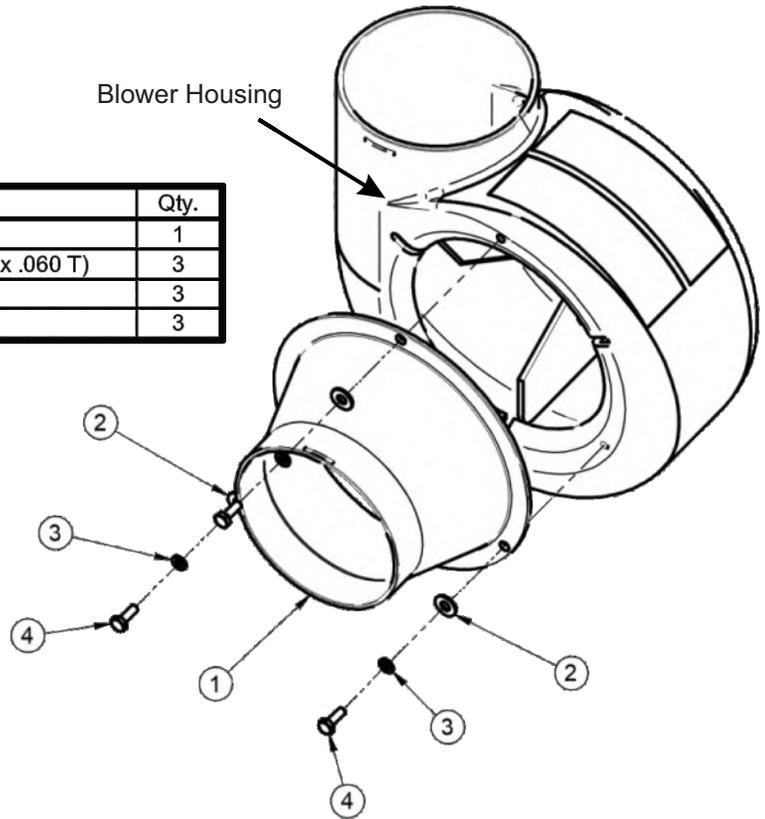

Boot Installation

Fasten Boot Plate P#(B0906) onto top of Boot and the Boot Plate Fastener P#(B0910) on the inside of Boot P#(V0048) using (3) P#(K1144) 5/16"-18 x 1" Carriage Bolts and (3) P#(K2516) 5/16"-18 Ny-Flange Locknuts. Align holes with the corresponding holes marked on the top plate. Lift mower's discharge chute and place boot on mower deck as shown. Refer to Figure B below.

Figure B



Length Of Hose Adjustment

The hoses in steps must be cut to fit your machine. Do not cut the hoses until you have tried to fit them on your machine. Remember that the hoses have to be long enough to adjust for the blower assembly's movement as well as allow for enough clamping surface between the inlet, blower assembly, and the deck boot.

Upper Hose Installation

Fasten the inlet to the plastic top by sliding the inlet from the inside of the top to the outside and lock into place. Slide a pre-assembled hose clamp onto both ends of the 6" upper hose (Figure A). Then slide one end of the 6" hose onto the inlet. Make sure there is about a two-inch overlap between the hose end and the container inlet. Proceed to slide the opposite end of the 6" hose onto the outlet of the blower assembly. See (Figure A) for details. Make sure both ends of the hose are clearly attached to the inlet and the blower assembly inlet. Tighten the hose clamps.

Lower Hose To Blower Cone Installation

Slide a pre-assembled hose clamp over both ends of the lower hose. Then proceed to slide the lower hose onto the blower cone. Tighten the hose clamp. The assembly should look like Figure A.

Lower Hose To Boot Installation

Take the unattached end of the lower hose and slide it over the circular end of the boot. Use the lower hose clamp to secure the hose to the boot (Figure A). Tip: Before securing clamp rotate hose counter-clockwise (away from yourself) approximately 1" to aid in retaining boot to mower deck.

Figure A

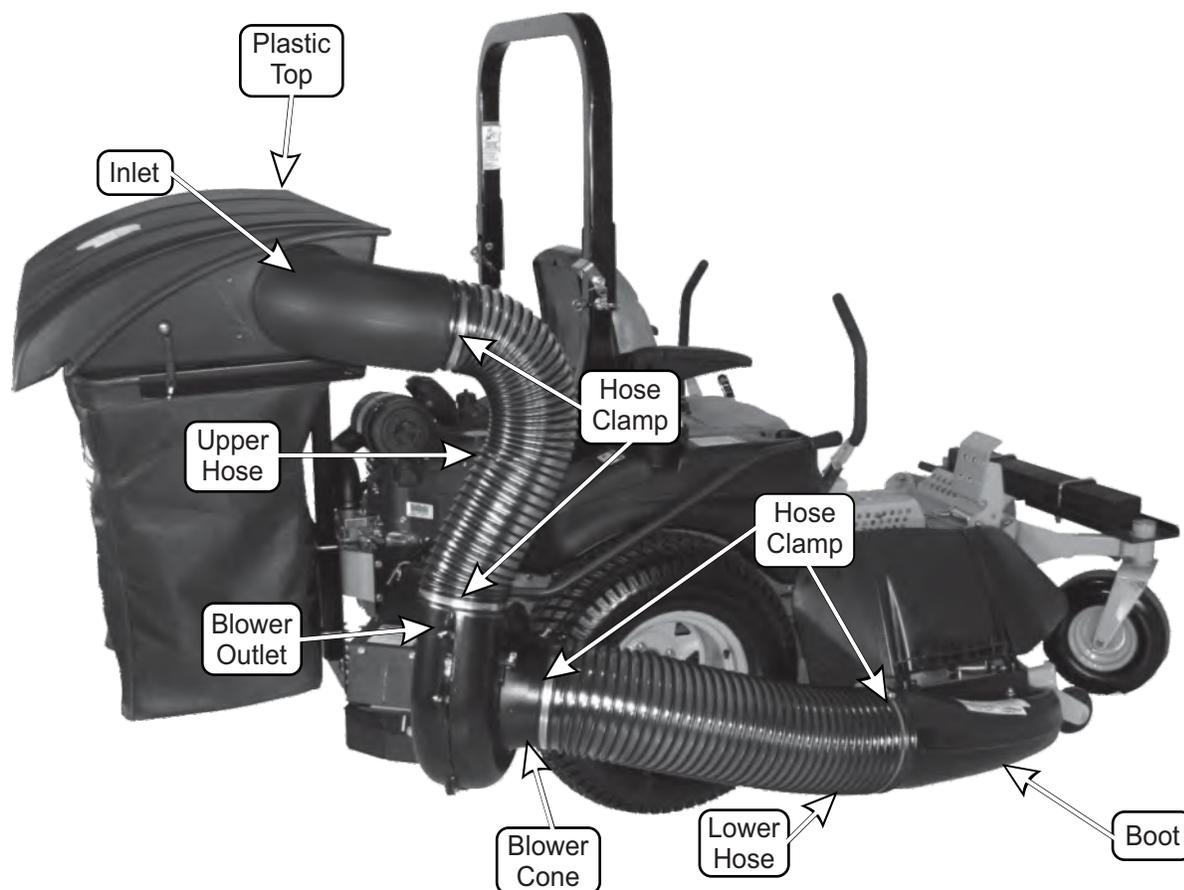

Impeller Blade Removal/Replacement

Removal

Step 1: Remove the blower cone from the blower housing located on the PTO assembly. With the blower cone removed, you will have access to the impeller blade assembly. Refer to Figure A.

Step 2: Remove the 5/16"-24 LH x 1-1/4" hex bolt P#(K1171) and washer P#(K1446).

Step 3: Insert the 1/2"-13 x 1" hex bolt (K1231) into the threads on the blade assembly and tighten. The blade should break free from the shaft.

Step 4: Remove the blade assembly and key from the PTO shaft.

Note: If necessary, use a break free agent to aid in the removal of the blade.

Installation

Step 1: Insert the key into the key way on the PTO shaft.

Step 2: Insert the blade assembly onto the PTO shaft.

Step 3: Secure the blade assembly to the PTO shaft with (1) washer P#(K1446) and (1) 5/16"-24 LH x 1-1/4" hex bolt. Torque the bolt to 19 ft./lbs.



WARNING

Before **REMOVING/REPLACING** the Impeller Blades, be sure the Mower is **TURNED OFF**, the PTO Assembly is **DISENGAGED** and The Negative Cable is **REMOVED** from the **BATTERY**. Failure to do so **MAY RESULT** in **SEVERE INJURY** or **DEATH**.

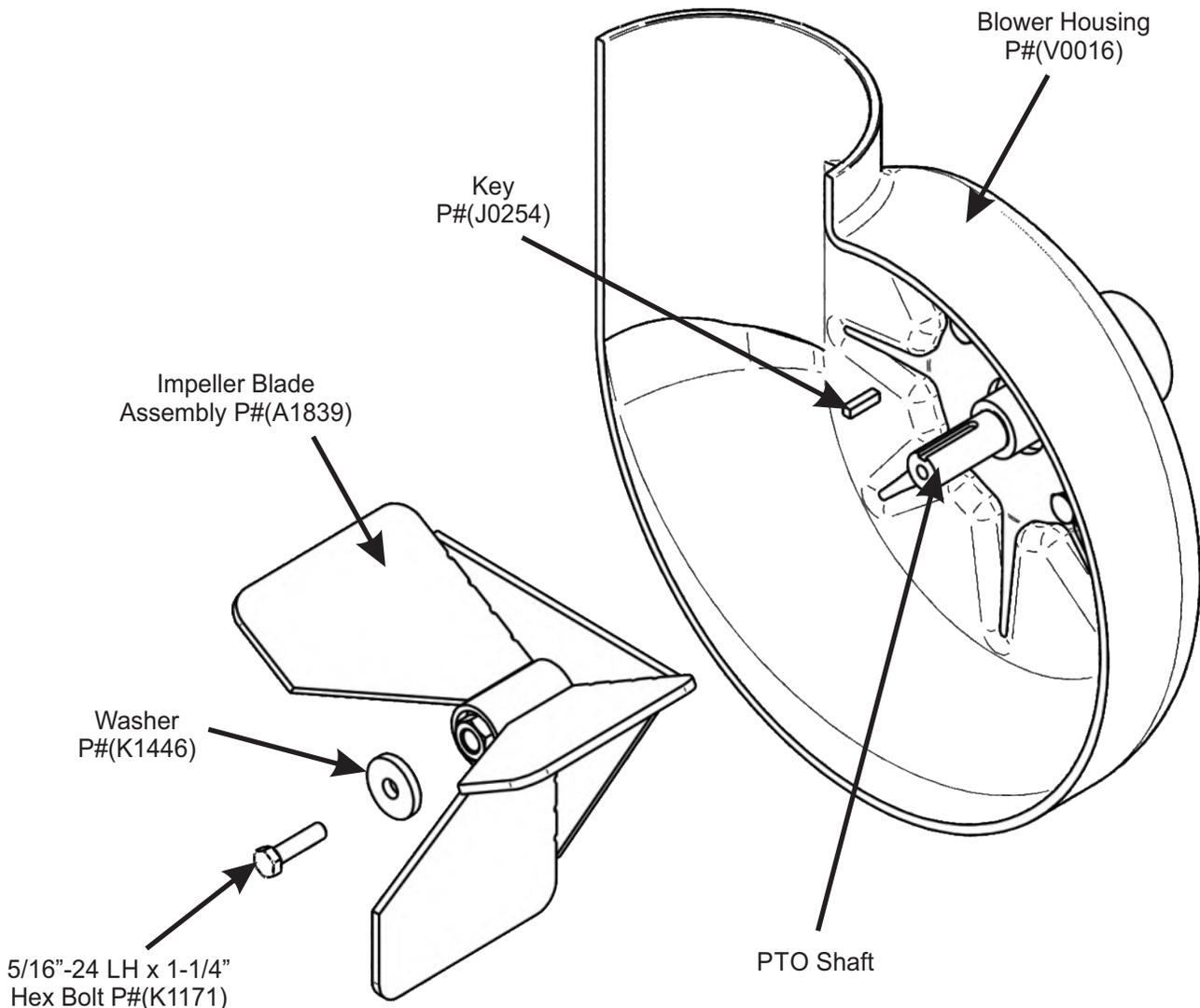

Weight Kit Installation

Place (2) U-Bolts P#(K0289) through the holes on the front side of Weight Bracket P#(B0941) and start (2) 1/2"-13 Ny-Flange Locknuts P#(K2012) on the backside of the Weight Bracket. Next, place Weight Bar P#(B0704) through U-Bolts and tighten firmly. Place Weight Bracket on front of footrest and secure using (2) 5/16"-18 x 3/4" Carriage Bolts P#(K1142) and (2) 5/16"-18 Ny-Flange Locknuts P#(K2516). (Note: On models with head lights, remove existing bolt and nut and discard. Be sure to bolt steel plate, holding the wire harness up, with new carriage bolts) Refer to Figure B below.

Figure A

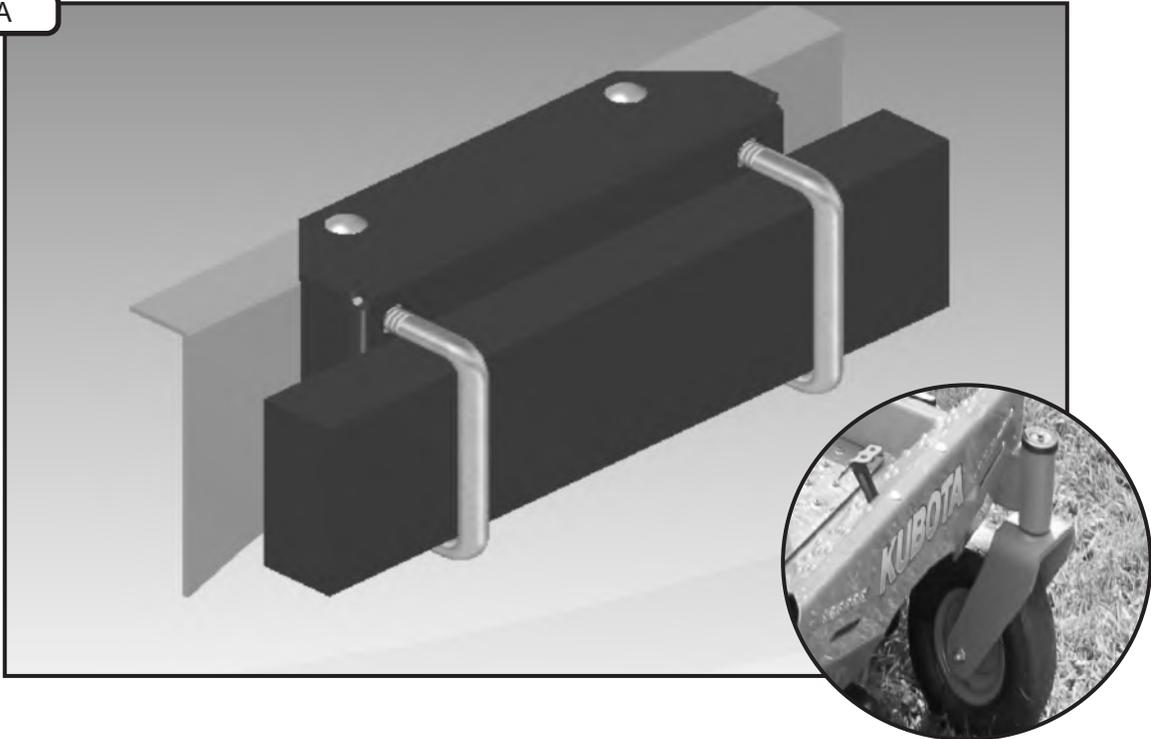
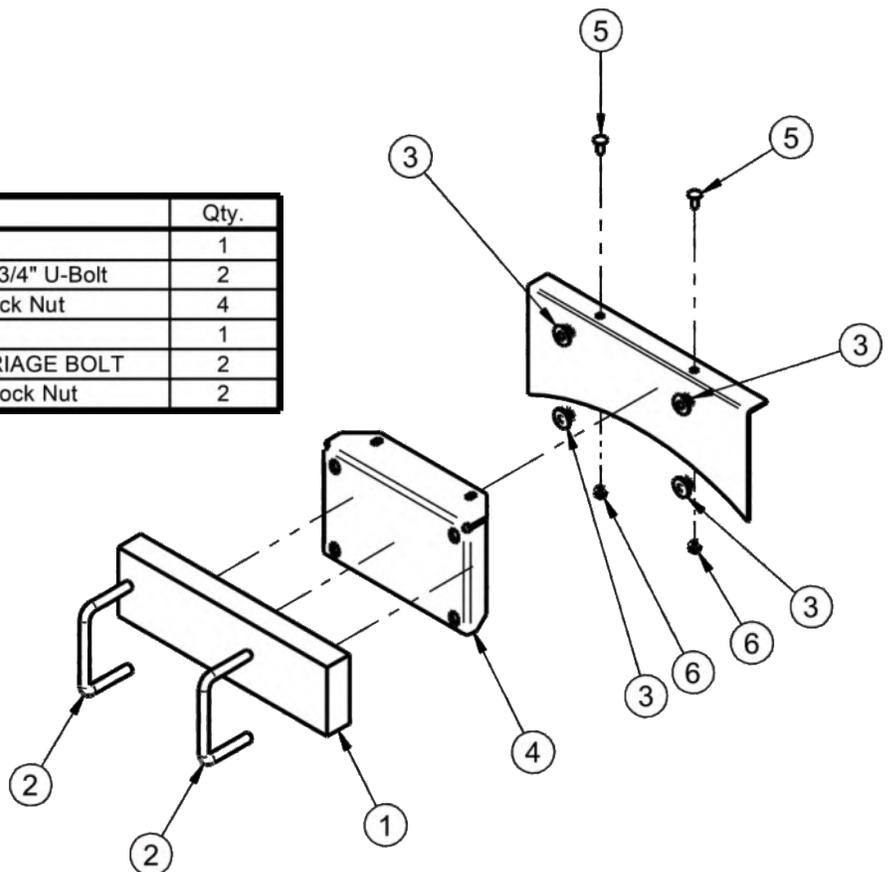
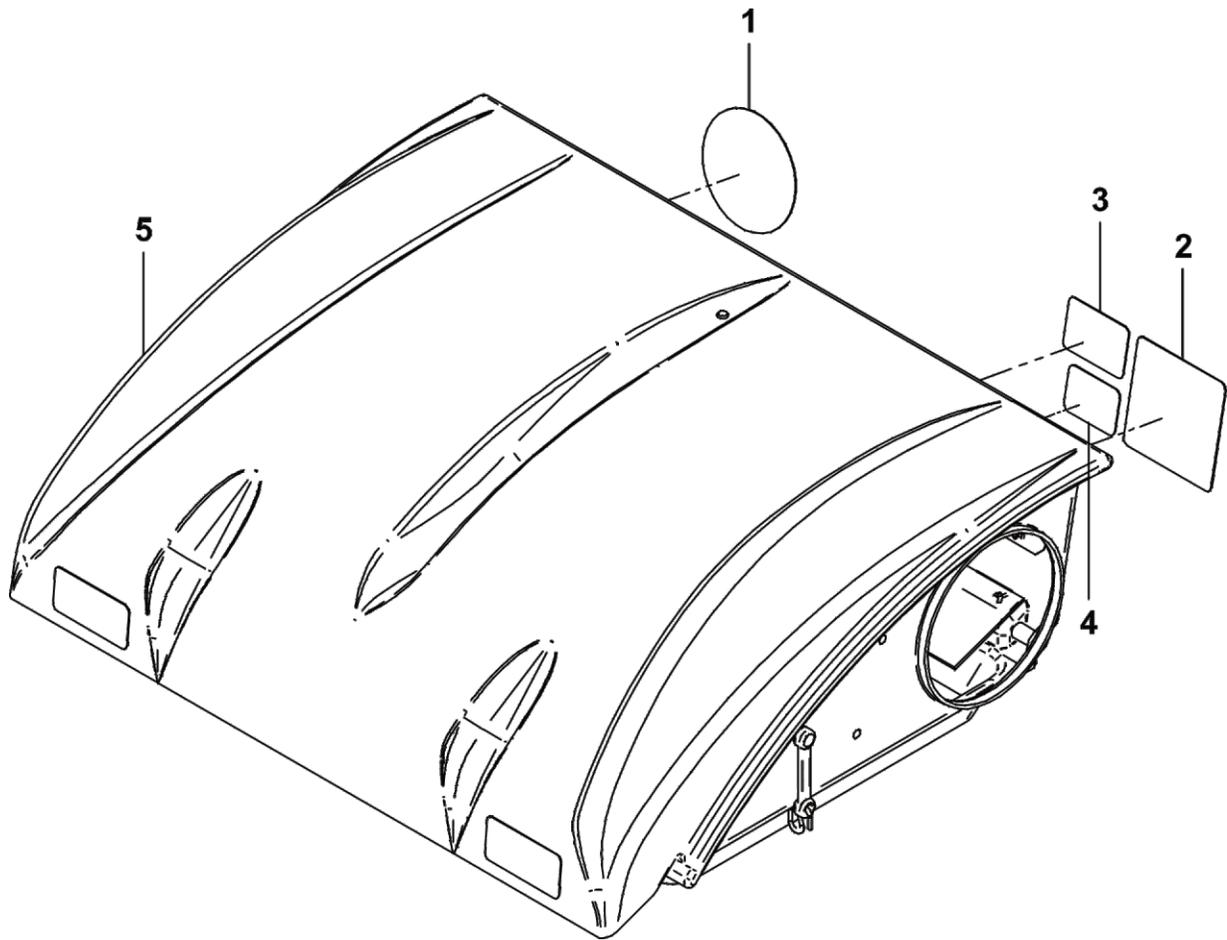

Figure B

Item #	Part #	Desc.	Qty.
1	B0704	Large Weight Bar	1
2	K0289	1/2"-13 x 4-5/16" x 2-3/4" U-Bolt	2
3	K2012	1/2"-13 Ny-Flange Lock Nut	4
4	B0941	Weight Bracket	1
5	K1142	5/16"-18 x 3/4" CARRIAGE BOLT	2
6	K2516	5/16"-18 Ny-Flange Lock Nut	2



**A2101 Top Assembly / Standard
Exploded Parts View**



Item #	Part #	Desc.	Qty.
1	R0022	Decal / Built In The USA / Lg	1
2	R1069	Decal / Warning - Turn Off Blower	1
3	R1054	Decal / Important Check Hoses	1
4	R1051	Decal / Warning - Use Hearing Protection	1
5	A2222	Top Assy / P2B+ Gen. 2 / Base Model	1

A2222 Top Assembly / Base Exploded Parts View

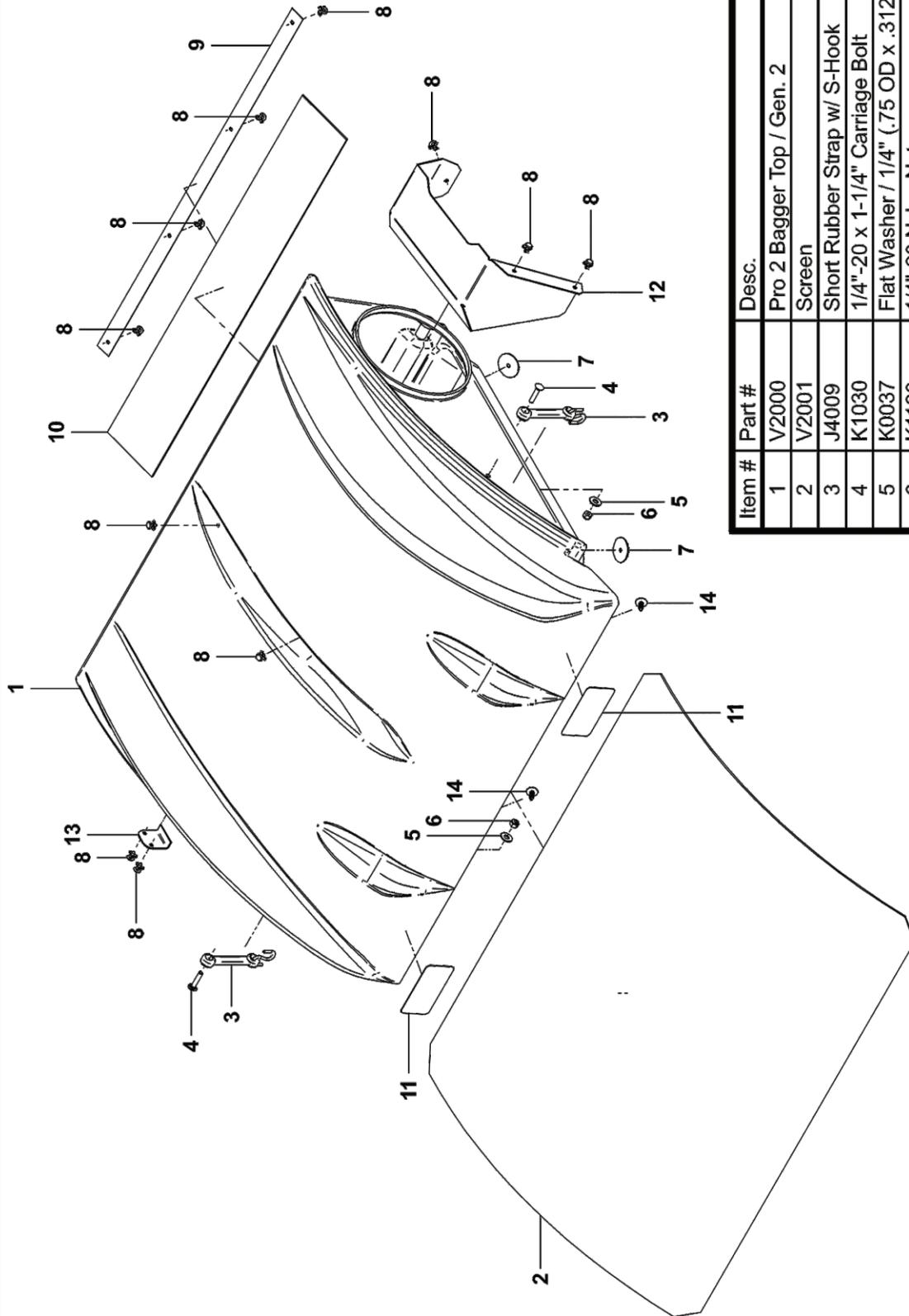

Item #	Part #	Desc.	Qty.
1	V2000	Pro 2 Bagger Top / Gen. 2	1
2	V2001	Screen	1
3	J4009	Short Rubber Strap w/ S-Hook	2
4	K1030	1/4"-20 x 1-1/4" Carriage Bolt	2
5	K0037	Flat Washer / 1/4" (.75 OD x .312 ID x .060 T)	2
6	K1128	1/4"-20 Nyloc Nut	2
7	K0062	Fender Washer / .230 ID x 1.500 OD / Zinc	2
8	K0114	Black Plastic Rivet	11
9	C0067	Dust Guard Mt. Brkt.	1
10	V1117	Dust Guard	1
11	R1057	Decal / 2" x 4" Red Reflector	2
12	C0026	Grass Deflector	1
13	B0676	Hinge Stop Pl.	1
14	K1265	Black Panel Retainer	2

A2194_01 PTO-R Base Assy Exploded Parts View

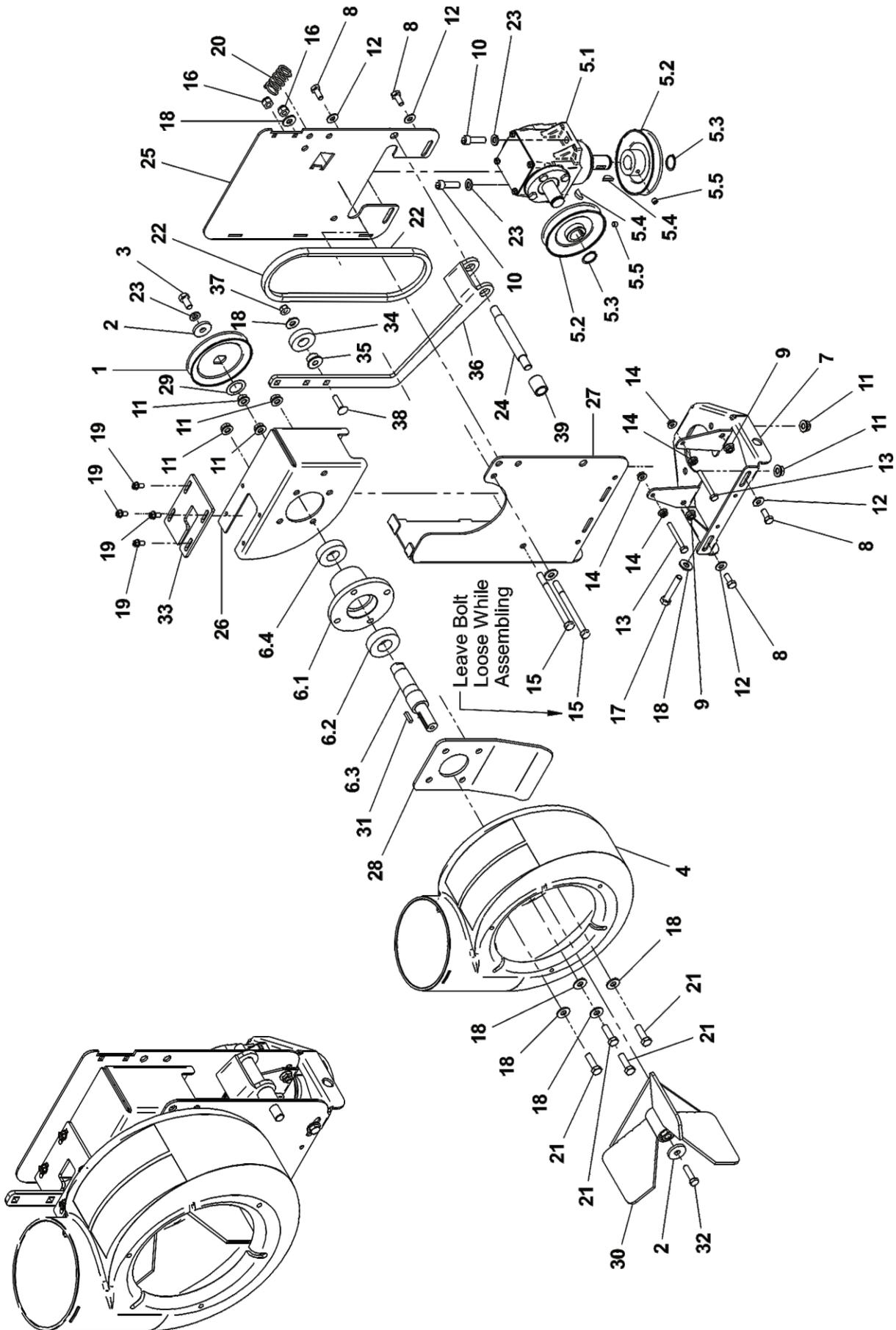

A2194_01 PTO-R Base Assy Exploded Parts List

Item #	Part #	Desc.	Qty.
1	M0266	A-Section Pulley / 4.25 OD	1
2	K1446	PTO Housing Washer	2
3	K1190	HHCS / 3/8"-16 x 3/4"	1
4	V0015	Blower Hsg.	1
5	A0429	Gear Box Assy.	1
5.1	A0431	Gearbox	1
5.2	A0498	Pulley Assy. / Gear Box	2
5.3	K0360	Snap Ring / 7/8" Shaft	2
5.4	J0272	Woodruff Key #9	2
5.5	K0035	Set Screw 5/16"-18 x 1/4" Cup Point	2
6	A1004	PTO Shaft Assy.	1
6.1	E0015	Housing / PTO Shaft	1
6.2	N0147	Bearing (2.0472 OD, 0.9843 ID, 0.5906 W)	1
6.3	B0460	PTO Shaft	1
6.4	N0165	Bearing (1.875 OD, .875 ID, .500 W)	1
7	A1003	PTO Base Plate Assy.	1
8	K1153	HHCS 5/16"-18 x 3/4"	4
9	K1178	Flange Nut 5/16"-18	4
10	K0309	3/8"-16 x 1-1/4" SHCS	2
11	K1215	Flange Nut 3/8"-16	6
12	K0037	Flat Washer / 1/4" (.75 OD x .312 ID x .060 T)	4
13	K1150	HHCS / 1/4"-20 x 2-1/4"	2
14	K1126	Flange Nut 1/4"-20	4
15	K1202	HHCS / 3/8"-16 x 4-1/2" / G5	2
16	K1216	Nyloc Nut / 3/8"-16	2
17	K0348	HHCS / 3/8"-16 x 2" All Thread	1
18	K0042	Flat Washer 5/16" / .875 OD x .380 ID x .075 T	8
19	K0353	HWHTCS 1/4"-20 x 1/2"	4
20	J0303	Spring	1
21	K1192	HHCS 3/8"-16 x 1-1/4" GR5	4
22	M0267	Kevlar Belt / A28K	1
23	K0048	Lock Washer 3/8"	3
24	B0505	Mount Rod	1
25	B0506_01	Lt. PTO Arm	1
26	B0642_01	Mount Bracket / Blower Hsg.	1
27	B0643_01	Rt. PTO Arm	1
28	B0739	Stiffener Plate / Blower Hsg.	1
29	K0070	Flat Washer (1.295 OD x .881 ID x .020 T)	1
30	A1839	3-Blade Impeller Assy.	1
31	J0254	Key / 3/16" x 3/16" x 3/4"	1
32	K1171	HHCS / 5/16"-24 LH x 1-1/4" / G5 w/ Patch Coating	1
33	B1875	Belt Tension Adjust Bracket	1
34	N0148	Bearing (1.625 OD, 0.750 ID, 0.4375 W)	1
35	S0021	Flange Bushing / Bearing	1
36	B1897	Base Handle	1
37	K2516	Ny-Flange Lock Nut 5/16"-18	1
38	K1146	5/16"-18 x 1-1/4" Carriage Bolt	1
39	S0229	Spacer Bushing	1

A1137_01 PTO-R Handle Ext. Kit Exploded Parts View

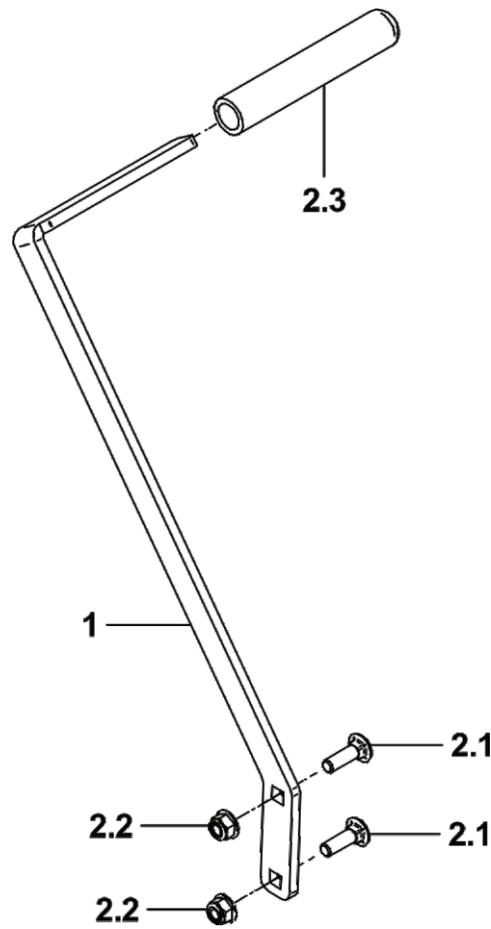

Item #	Part #	Desc.	Qty.
1	B0683_01	Handle Ext. / PTO-R	1
2	HB0783	HW Bag / Handle Ext. Kit / PTO-R	1
2.1	K1144	5/16"-18 x 1" Carriage Bolt	2
2.2	K2516	Ny-Flange Lock Nut 5/16"-18	2
2.3	V1151	Black Handle Grip (5/8" ID x 4-3/4" L)	1

SAFETY DECALS

To promote safe operation, New PECO, Inc. supplies safety decals on all products manufactured. Damage can occur to safety decals either through shipment, use or reconditioning. Contact your local Service Center for replacement decals.



Part# R1070
PECO Logo



Part# R0022
Designed & Built
In The USA



Part #: R2007
Danger - Never
Use Hands

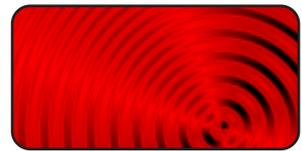

Part #: R2008
Danger - Rotating
Blades



Part #: R1057 - (2)
Red Reflectors

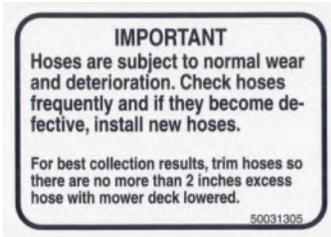

Part #: R1054
Important - Hose Wear



Part #: R1100
Engage-Disengage Label



Part #: R1069
Warning - Turn Off Blower



Part #: R4037
Warning: Hot Surface Label



Part #: R1051
Warning - Hearing Protection



Part # R0025
Danger - Rotating
Blades



Part # R0024
Danger - Keep Hands
Clear

Troubleshooting

2017 (v1.0)

Collection System Performance

Problem	Possible Cause	Corrective Action
Abnormal Vibration	<ul style="list-style-type: none"> • Cutting blades are bent or unbalanced • Loose blower pulley or pulley assembly • Impeller blade out of balance 	<ul style="list-style-type: none"> • Install new cutting blade • Tighten the pulley • Contact dealer to replace
Reduced collection system performance	<ul style="list-style-type: none"> • Low engine speed • Plugged screen • Loose belt • Full collection bags 	<ul style="list-style-type: none"> • Always operate collection system at full throttle • Remove debris, leaves, or grass clippings from the screen • Replace/tighten belt • Empty the collection bags
Blower and hoses plugging too frequently	<ul style="list-style-type: none"> • Collection bags are too full • Low engine speed • Grass is too wet • Grass is too long • Ground speed is too fast • Worn belt • Loose belt 	<ul style="list-style-type: none"> • Dump more frequently • Always operate collection system at full throttle • Cut grass when it is dry • Cut the grass several times • Drive slower at full throttle • Replace belt • Adjust the pulley and tighten belts
Debris blowout	<ul style="list-style-type: none"> • Collection bags are too full • Plug/clog in the collection system • Ground speed is too fast 	<ul style="list-style-type: none"> • Dump more frequently • Clean the collection system • Drive more slowly at full throttle
Impeller doesn't rotate freely	<ul style="list-style-type: none"> • Plug in the blower housing • Worn impeller blade • Shaft bearings bad/failing 	<ul style="list-style-type: none"> • Clean the blower housing • Contact dealer to replace • Contact dealer to replace

Notes



New PECO, Inc.
10 Walden Dr | Arden, North Carolina 28704
Phone: 1-800-438-5823 | 828-684-1234
Fax: 828-684-0858
Email: peco@lawnvac.com
Website: www.lawnvac.com