



PTO-X DRIVEN - GRASS COLLECTION SYSTEM

Dixie Chopper Eagle

Jacobsen ZT900

Model Year: **2018 - Newer**

Deck Sizes: **54" & 60"**

Model # **38651201**

Pro12 DFS



OPERATOR'S MANUAL

ASSEMBLY • OPERATION • MAINTENANCE

GRASS COLLECTION SYSTEM

TABLE OF CONTENTS

SECTION	PAGE	SECTION	PAGE
Safety	2	Inlet, Inlet Ring & Debris Deflector Installation	20
Safety Alert Symbols	3	Wiring Harness Installation	21-22
Warranty	4	Length of Hose Adjustment	23
I INTRODUCTION AND DESCRIPTION	5	Upper Hose Installation	23
Introduction	5	Lower Hose To Blower Cone Installation	23
Description	5	Lower Hose To Boot Installation	23
II INSTALLATION FOR USE	6	Impeller Blade Removal/Replacement	24
Preparation Of Mower	6	Weight Kit Installation	25-26
Left Mount Plate Installation	7	Exploded Views & Parts List	27-38
Right Mount Plate Installation	8	Overall Parts List	39
Rear Mount Plate Installation	9	Safety Decals	40
PTO Mount Plate Installation	10	III OPERATING INSTRUCTIONS	41
Mount Arm/Tube Assy Installation	11	General Safety	41
Main Frame Mount Installation	12	Operation & Tips On Mowing	41
Main Frame Assy Installation	13	Disengagement Of The PTO Assembly	41
PTO Drive Assy	14-15	Unloading The Collection System	41
Drive Assy & Belt Installation	16	IV MAINTENANCE	41-42
Boot Kit Installation	17	Maintenance Checklist	41
Lift Handle Installation	18	Lubrication	42
Aluminum Box Assy Installation	19	V PARTS AND SERVICE	42
Dump Mechanism Adjustment	19	Parts And Service Information	42
		Torque Specifications	43
		Troubleshooting	44

SAFETY

1. Read the operator's manual carefully and familiarize yourself with the proper use of your attachment. Do not allow anyone who is not acquainted with the Safety Instructions to use your attachment.
2. Know the controls and how to stop them quickly. **READ THE OPERATOR'S MANUAL!**
3. Do not allow children to operate the machine. Do not allow adults to operate it without proper instruction.
4. Be especially watchful of children and pets entering into the area while operating.
5. Keep your eyes and mind on your machine while mowing or operating your attachment. Don't let others distract you.
6. Do not attempt to operate your machine when not in the driver's seat.
7. Always shut off blades and engine when emptying the container.
8. Stop machine, shut off deck attachment, set parking brake, shut off engine and remove ignition key before removing clogs, removing or replacing hose, boot, blower cone, or performing any maintenance.
9. Mow across the face of slopes (not more than 10 degrees); never up and down the face.
10. It is recommended that the container be emptied when half full while operating on slopes. Start mowing on slopes when the container is empty.
11. Inspect your lawn and remove any foreign objects before mowing. Never deliberately run the mower across any foreign object.
12. Wear hearing protection.
13. Wear eye protection to prevent debris from getting into your eyes.

SAFETY

WARNING! NEVER operate the mower unless the discharge guard and either the deflector assembly or the vacuum collector adapter are fastened securely in place.

WARNING! Do not work around the mower deck boot or the blower area until you are certain that the mower blades and the blower impeller have stopped rotating.

WARNING! To avoid serious injury, perform maintenance on the vacuum collector; **ONLY AFTER STOPPING THE MOWER'S ENGINE AND WAITING FOR ALL MOVING PARTS TO COME TO A COMPLETE STOP.** Set the parking brake. Always remove the ignition key before beginning maintenance.

WARNING! For your own personal safety, **ALWAYS mow ACROSS the face of slopes and NEVER UP and DOWN the face. NEVER attempt to mow excessively steep slopes, and use caution when turning on any slope.**

Safety Alert Symbol



This Safety Alert Symbol means: **“ATTENTION! BECOME ALERT! YOUR SAFETY IS INVOLVED!”**

This symbol is used to call attention to safety precautions that should be followed by the operator to avoid accidents. When you see this symbol, carefully read the message that follows and heed its advice. Failure to comply with safety precautions could result in death or serious bodily injury.

Safety Signs

The signal words **DANGER**, **WARNING**, and **CAUTION** are used on the equipment safety signs. These words are intended to alert the viewer to the existence and the degree of hazard seriousness.



White letters on **RED**

This signal word indicates a potentially hazardous situation which, if not avoided, will result in death or serious injury.



Black letters on **ORANGE**

This signal word indicates a potentially hazardous situation which, if not avoided, could result in death or serious injury.

It may also be used to alert against unsafe practices.



Black letters on **YELLOW**

This signal word indicates a potentially hazardous situation which, if not avoided, will result in minor or moderate injury.

It may also be used to alert against unsafe practices.

PECO LIMITED WARRANTY FOR NEW PRODUCTS

New PECO, Inc. extends the following warranties to the ORIGINAL PURCHASER of each New PECO, Inc. consumer product purchased from one of our Dealers or directly from New PECO, Inc., subject to the following limitations:

A. ITEMS COVERED UNDER WARRANTY

1. **PRODUCT WARRANTY** – Any part or parts which are deemed defective in material or workmanship, as delivered to the original purchaser, will either be repaired or replaced, as New PECO, Inc. elects, without charge for parts or labor, if the defect appears within 12 months from the date of purchase of the product to the Original Purchaser.
2. **PARTS REPLACED DURING WARRANTY** – Any New PECO, Inc. part which is furnished in performance of this warranty and is defective in material or workmanship as delivered to the purchaser will be repaired or replaced, as New PECO, Inc. elects, before the expiration of the original warranty period.

B. WARRANTY DISTINCTIONS

1. **RESIDENTIAL** - Products put to a personal use around a single household or residence are considered Residential. Products designated as “Residential” are warranted for 12 months from the date of purchase of the product, to the ORIGINAL PURCHASER with proof of purchase, when used for or in residential applications.
2. **COMMERCIAL** – Products put to any business use (agricultural, commercial or industrial) or used at multiple locations are considered Commercial. Products designated as “Commercial” are warranted for 12 months from the date of purchase of the product, to the ORIGINAL PURCHASER with proof of purchase, when used for or in commercial applications. Products designated as “Residential” are warranted for 90 days from the date of purchase of the product, to the ORIGINAL PURCHASER with proof of purchase, when used for or in Commercial applications.
3. **RENTAL** – Products used for Rental or Lease Purposes are warranted for 45 days from date of purchase of the product, to the ORIGINAL PURCHASER with proof of purchase, when used for or in a rental business.

C. ITEMS NOT COVERED BY NEW PECO WARRANTY

1. **ENGINES & BATTERIES:** Engines and Batteries attached to New PECO, Inc. products are covered under their respective separate manufacturer warranties and those companies must be contacted directly to file a warranty claim. Briggs & Stratton: https://www.briggsandstratton.com/na/en_us/support/warranty.html
2. **UNAPPROVED ALTERATION OR MODIFICATION:** All obligations of New PECO, Inc. under this warranty shall be terminated if products are altered or modified in any way not approved by New PECO, Inc.
3. **ACCIDENTS & NORMAL MAINTENANCE:** This warranty covers ONLY manufacturers defective material and workmanship. It does not cover depreciation or damage caused by normal wear & tear, accident, improper maintenance, misuse or abuse of products. New PECO, Inc. products must be operated and maintained in accordance with the instructions furnished in the manuals. The cost of normal maintenance and normal replacement of service items such as belts, cutting blades, hoses, bags, etc., which are not defective shall be paid for by the purchaser.
4. **NO SERVICE CENTER WARRANTY:** The selling Service Center/Dealer makes no warranty on his own on any item warranted by New PECO, Inc. unless he delivers to purchaser a separate written warranty certificate specifically warranting the item. The Service Center or Dealer has no authority to make any representation or promise on behalf of New PECO, Inc. or to modify the terms of the original warranty in any way.
5. **NO REPRESENTATIONS ADDITIONAL WARRANTIES, DISCLAIMER:** Neither New PECO, Inc. nor any company affiliated with New PECO, Inc. makes any warranties, representations or promises as to the quality of performance of its products other than those set forth herein. Except as described above, New PECO, Inc. makes no other warranties **AND SPECIFICALLY DISCLAIMS ANY AND ALL IMPLIED WARRANTIES OF FITNESS AND MERCHANTABILITY.**
6. **REMEDIED EXCLUSIVE:** The only remedies the purchaser has in connection with the breach or performance of any warranty on New PECO, Inc. consumer products are set forth above. In no event will New PECO, Inc. be liable for special incidental or consequential damages.

Warranty service is available through your local authorized service dealer or distributor. If you do not know the dealer or distributor in your area, search by your zip code on www.lawnvac.com or contact our Sales Department at New PECO, Inc. 800-438-5823 or email Sales@lawnvac.com.

Section I - INTRODUCTION AND DESCRIPTION

Introduction

We are pleased to have you as a PECO customer. Your collection system has been designed to give you a low maintenance, simple, and effective way to collect the grass clippings from your mower. The manuals are provided to give you the necessary instructions to properly mount, operate and maintain the collection system on your mower. Please read this manual thoroughly. Understand what each control is for and how to use it. Observe all safety decal precautions on the machine and noted throughout the manual.

NOTE: All references made to right, left, front, rear, top or bottom are as viewed from the normal operator's position on the mower.

Description

The grass collection system is designed for turf maintenance where there is a need to collect the grass clippings as the mower cuts the turf. It is also used for picking up leaves in pre-season and post-season clean-up. The blower, mounted on the right side of the unit, uses a belt and gearbox system from the engine PTO shaft. Drive train protection comes through belt slippage. The blower draws grass clippings from the discharge area of the cutting deck back to the collection bags at the rear portion of the mower frame. The operator can engage the blower with a push of the over-center linkage on the right side of the unit. Once the bags are full with clippings, they can be easily released for dumping.



Section II - INSTALLATION FOR USE

Preparation Of Mower

NOTE: The mower deck PTO belt must be removed from the electric clutch before continuing with the installation. Refer to your mower's owner's manual for instructions on PTO belt removal.

From the underside of the engine, disconnect the wiring harness attached to the electric clutch. Remove the bolt and electric clutch from the mower. Refer to Figure A.

Figure A

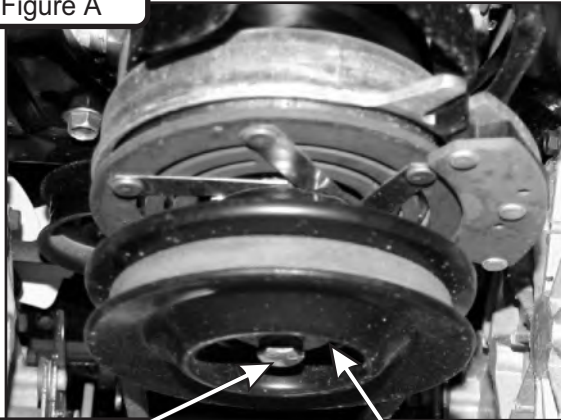

Remove Bolt

D-Drive Spacer

Upon removal of clutch determine if your mower is equipped with a D-drive spacer. If so, then proceed to Figure B. If your mower is equipped with bolt, fender and lock washer without D-drive spacer proceed to Figure C. Remove the D-drive spacer using an arbor press or equivalent. On removal, adjacent bearing OUTER race must be supported or bearing damage may occur. Refer to Figure B.

Figure B

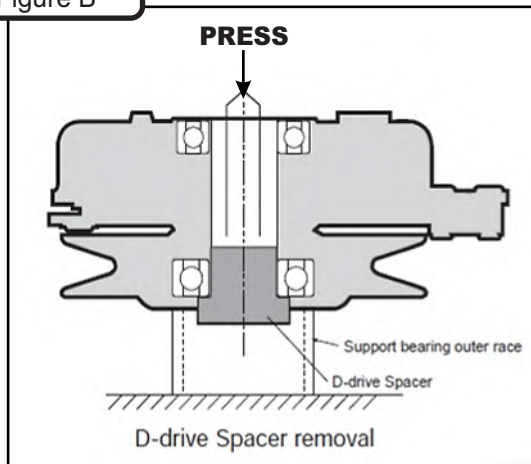
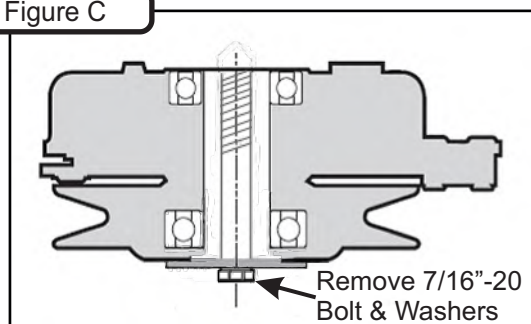
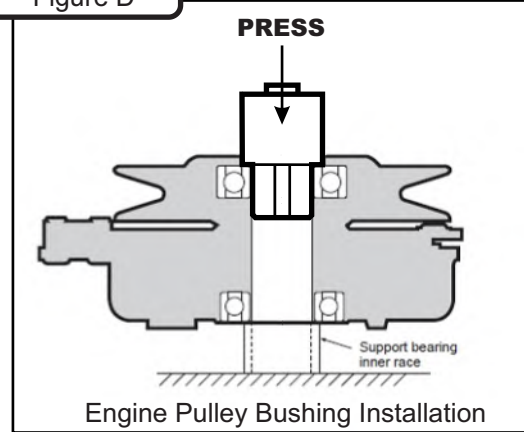

Figure C



The engine pulley assembly must be installed using an arbor press or equivalent. During installation, opposite bearing inner race must be supported or bearing damage may occur. Refer to Figure D.

Figure D



Once the Engine Pulley Bushing is installed, reattach the clutch assembly & deck PTO belt to the mower and then review Figure E.

Figure E

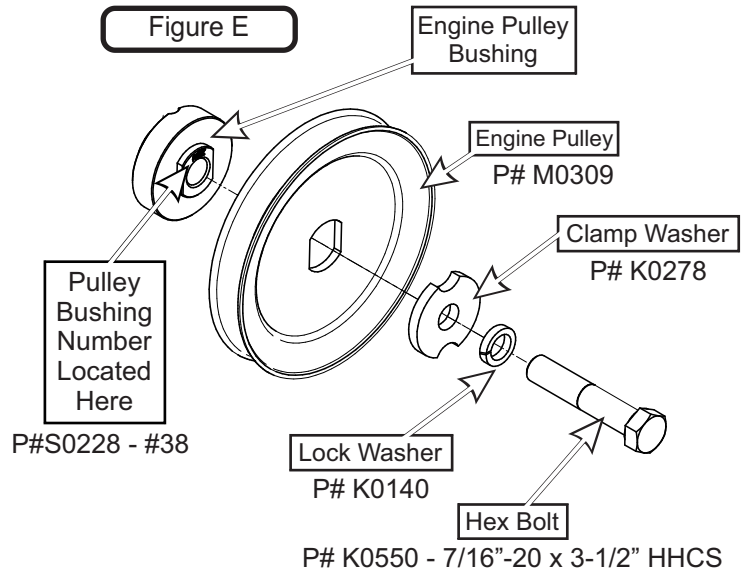

To assemble and fasten the Engine Pulley, align the Engine Pulley Bushing to the mower's clutch pulley and fasten using (1) Clamp Washer, (1) Lock Washer, and (1) Hex Bolt. Torque the bolt to 55 ft./lbs. The added pulley will power the collection system and should resemble Figure F when installed.

Figure F

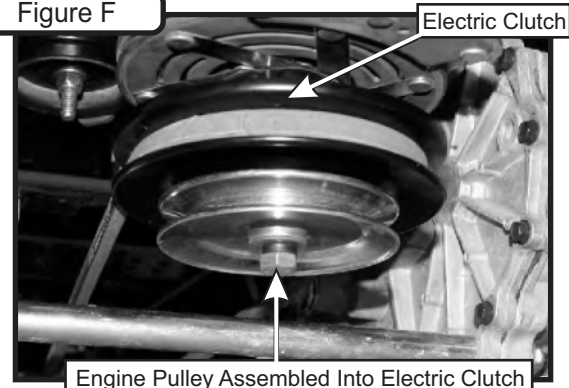

Left Mount Plate Installation

Before installing the Left Mount Plate (Item #1), remove the hardware fastening the lower left side of the mower's rear bumper to reveal (2) bolt holes.

Next, align the bottom (2) left bolt holes of the Left Mount Plate to the ones on the lower left side of the mower's rear bumper. Secure the Left Mount Plate to mower by using (2) 3/8"-16 x 1-1/4" Carriage Bolts (Item #2) and (2) 3/8"-16" Ny-Flange Lock Nuts. Refer to Figure A.

Note: Some part features have been hidden from view for visual clarity.

Item #	Part #	Desc.	Qty.
1	B1090	Left Mount Plate	1
2	K1183	Carriage Bolt 3/8"-16 x 1-1/4"	2
3	K2038	Ny-Flange Lock Nut 3/8"-16	2

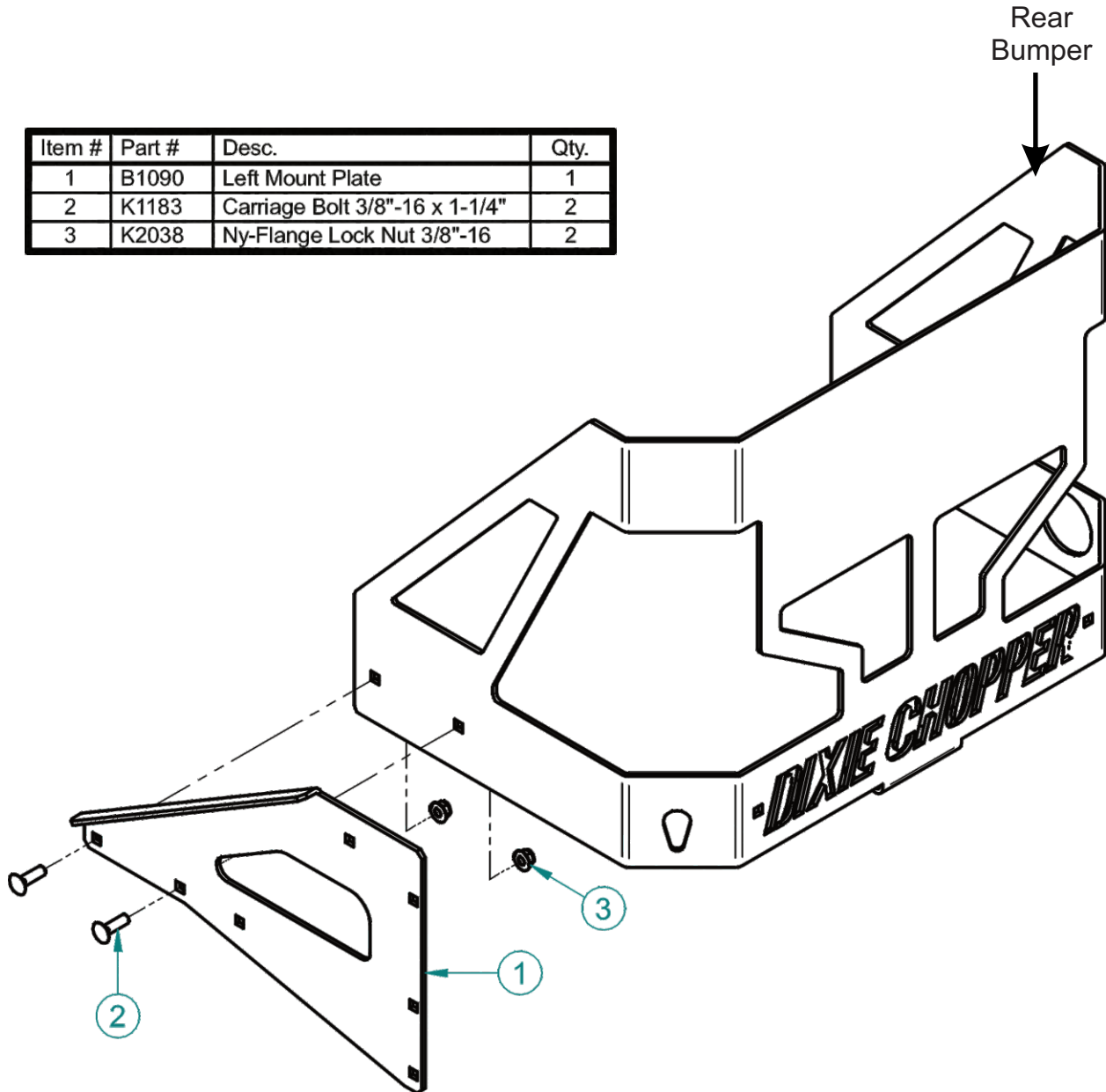

Right Mount Plate Installation

Before installing the Right Mount Plate (Item #1), remove the hardware fastening the lower right side of the mower's rear bumper to reveal (2) bolt holes. Then remove the hardware from the lower bolt hole of the right side of the ROPS to reveal (1) bolt hole.

Next, align the bottom (2) right bolt hole of the Right Mount Plate to the ones on the lower right side of the mower's rear bumper and align the top right bolt hole of the Right Mount Plate to the one on the ROPS, refer to the figure below. Secure the Right Mount Plate to the mower by using (1) 1/2"-13 x 3-1/2" Hex Bolt (Item # 2), (1) 1/2" Flat Washer (Item #3), (1) 1/2"-13 Flange Nut (Item #4), (2) 3/8"-16 x 1-1/4" Carriage Bolts (Item #5) and (2) 3/8"-16" Ny-Flange Lock Nuts (Item #6). Refer to the figure below.

Leave the (2) 3/8"-16 x 1-1/4" Carriage Bolt and (2) 3/8"-16 Ny-Flange Lock Nuts relatively loose for the installation of the PTO Mount Arm.

Note: Some parts and part features have been hidden from view for visual clarity.

Item #	Part #	Desc.	Qty.
1	B1081	Right Mount Plate	1
2	K1237	1/2"-13 x 3-1/2" HHCS GR5	1
3	K0055	Flat Washer 1/2" / 1.383 OD x .560 ID x .120 T	1
4	K1246	Flange Nut 1/2"-13	1
5	K1183	Carriage Bolt 3/8"-16 x 1-1/4"	2
6	K2038	Ny-Flange Lock Nut 3/8"-16	2

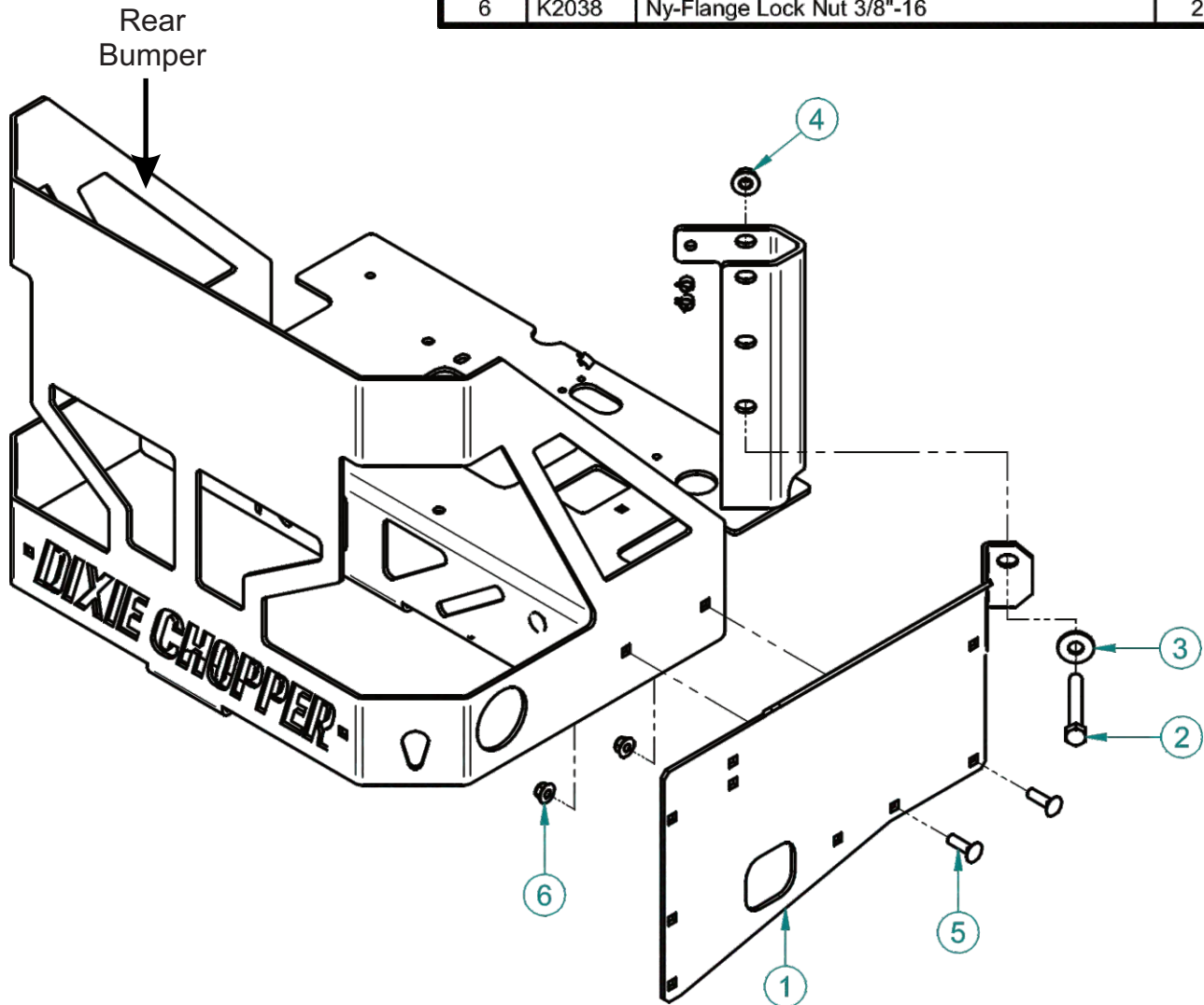

Rear Mount Kit Assembly Installation

Before the installation of the Rear Mount Plate (Item #1), remove the existing hardware underneath the rear bumper around the hitch receiver.

Position the Rear Mount Plate to the mower's rear bumper and align the bottom (2) bolt holes located on the bottom tab of the Rear Mount Plate to those on the mower's rear bumper, see Figure A. Secure the Rear Mount Plate, relatively loose, using (2) 3/8"-16 x 1-1/2" Carriage Bolts (Item #2), (2) Spacers (Item #3) and (2) 3/8"-16 Ny-Flange Lock Nuts (Item #4). Refer to Figure A.

Next, align the side bolt holes of the Rear Mount Plate to those on the Left and Right Mount Plate. Secure the Rear Mount Plate to the Left Mount Plate using (3) 3/8"-16 x 1" Carriage Bolts (Item #2) and (3) 3/8"-16 Ny-Flange Lock Nuts (Item #3). Secure the Rear Mount Plate to the Right Mount Plate Using (1) 3/8"-16 x 1" Carriage Bolt (Item #1) and (1) 3/8"-16 Ny-Flange Lock Nut (Item #3). Refer to Figure B. Tighten all hardware at this time.

Note: Some parts and part features have been hidden from view for visual clarity.

Figure A

Item #	Part #	Desc.	Qty.
1	B1084	Rear Mount Plate	1
2	K1337	Carriage Bolt 3/8"-16 x 1-1/2"	2
3	S3287	Spacer .437 ID x .750 OD x .250 T	2
4	K2038	Ny-Flange Lock Nut 3/8"-16	2

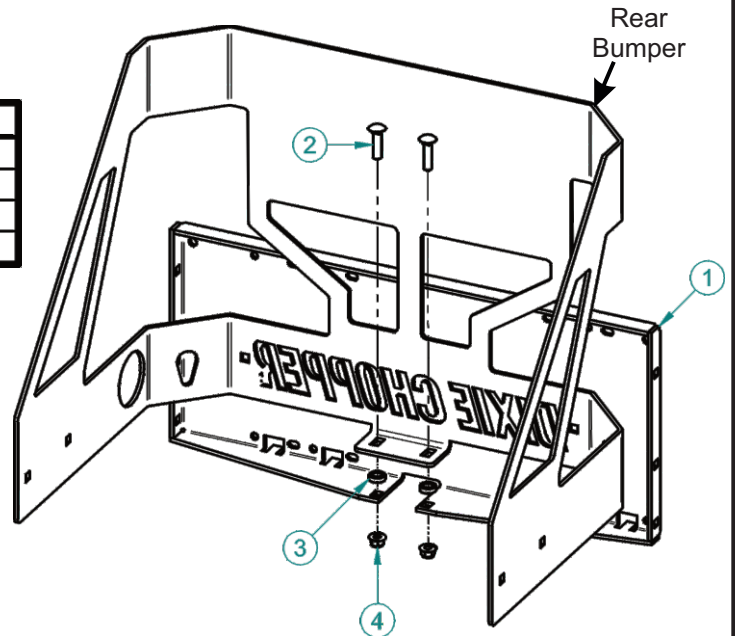
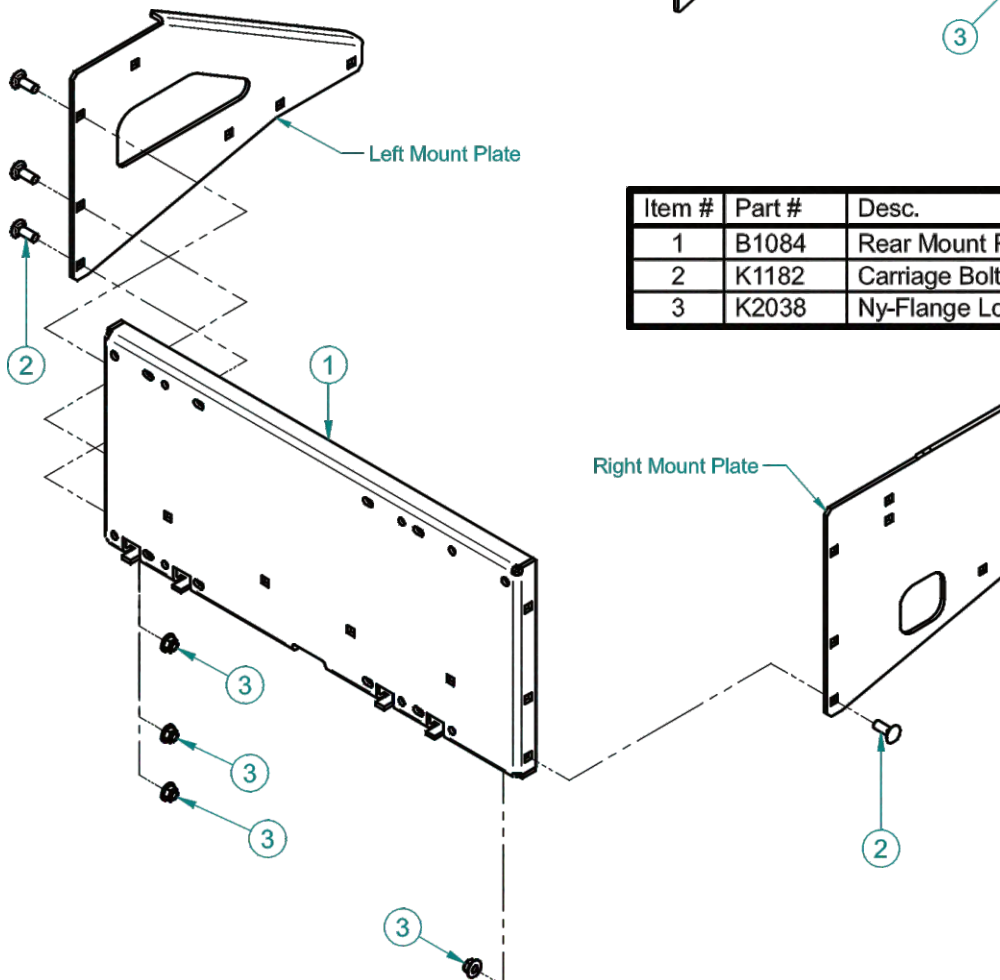

Figure B



Item #	Part #	Desc.	Qty.
1	B1084	Rear Mount Plate	1
2	K1182	Carriage Bolt 3/8"-16 x 1"	4
3	K2038	Ny-Flange Lock Nut 3/8"-16	4

PTO Mount Plate Installation

Before installing the Lower Mount Plate (Item #1) first install the included Exhaust Diverter (Item #J0292) and secure with Exhaust Clamp (Item #X1064). Next loosen and remove the (2) bottom pair of hardware previously used to secure the bottom right of the Right Mount Plate, see Figure A. To install the Lower PTO Mount Plate (Item #1), Align the row of carriage bolt holes of those of the Lower PTO Mount Plate located on the bottom of the Right Mount Plate. Secure the Lower PTO Mount Plate by using (1) 3/8"-16 x 1-1/2" Carriage Bolt (Item #2), (2) 3/8"-16 x 1-1/4" Carriage Bolt (Item #3) and (3) 3/8"-16 Ny-Flange Lock Nuts (Item #4). Refer to Figure A.

Note: Some parts and part features have been hidden from view for visual clarity with the figures below.

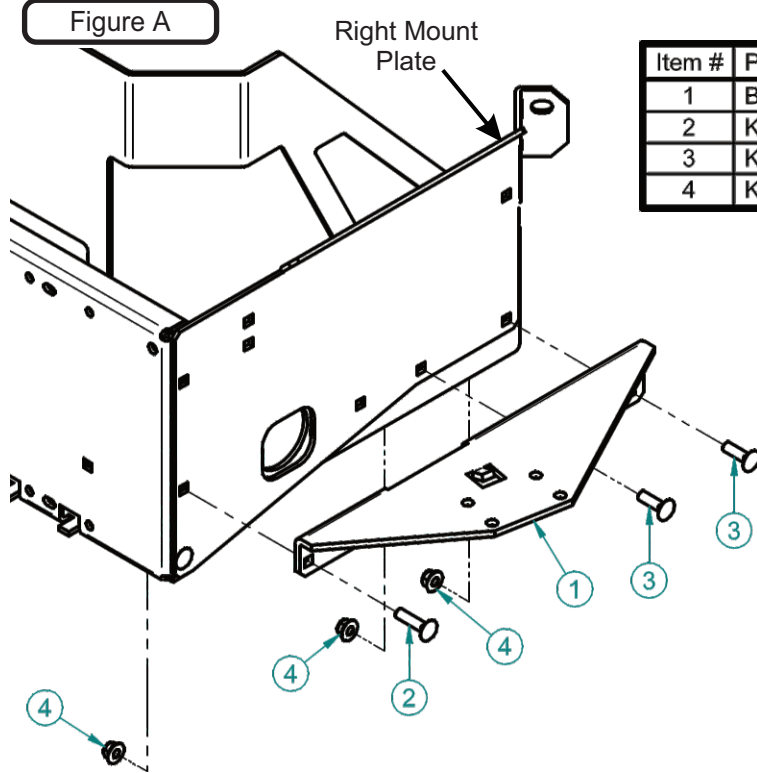

Item #	Part #	Desc.	Qty.
1	B1082	Lower PTO Mount Plate	1
2	K1337	Carriage Bolt 3/8"-16 x 1-1/2"	1
3	K1183	Carriage Bolt 3/8"-16 x 1-1/4"	2
4	K2038	Ny-Flange Lock Nut 3/8"-16	3

To Install the Top Mount Plate (Item #1), align the row of carriage bolt holes to those located on the top of the Right Mount Plate, see Figure B. Secure the Upper PTO Mount Plate by using (1) 3/8"-16 x 1-1/2" Carriage Bolt (Item #2), (2) 3/8"-16 x 1-1/4" Carriage Bolt (Item #3) and (3) 3/8"-16 Ny-Flange Lock Nuts (Item #4). Refer to Figure B.

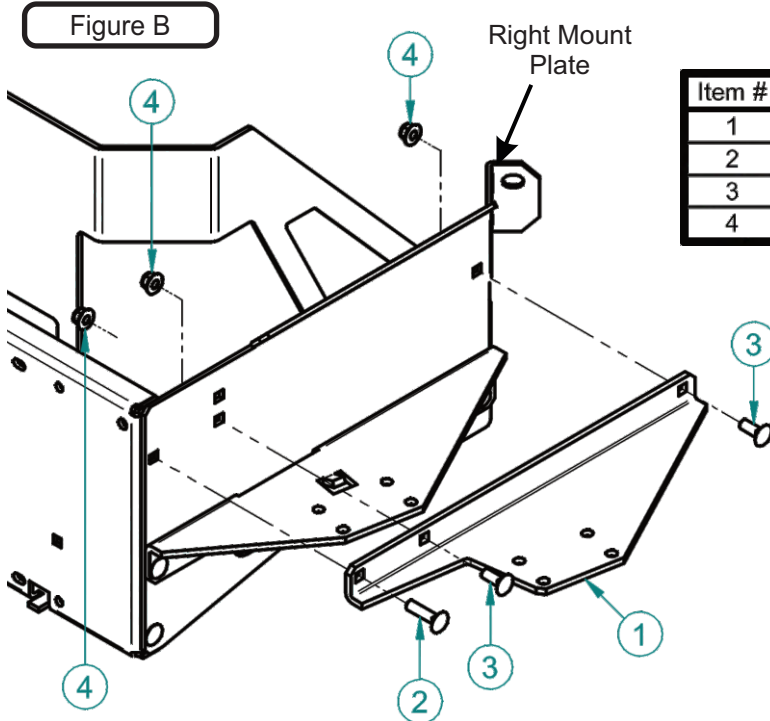

Item #	Part #	Desc.	Qty.
1	B1083	Upper PTO Mount Plate	1
2	K1337	Carriage Bolt 3/8"-16 x 1-1/2"	1
3	K1182	Carriage Bolt 3/8"-16 x 1"	2
4	K2038	Ny-Flange Lock Nut 3/8"-16	3

Mount Arm / Tube Assembly Installation

Position and place the Mount Arm / Tube Assembly (Item #1) between the Upper and Lower PTO Mount Plate. Make sure the back of the Mount Arm / Tube is resting against the bottom stop tab of the Lower PTO Mount Plate, see Figure B. Secure the Mount Arm / Tube to the Upper and Lower Mount Plate by using (4) Grade 5 3/8"-16 x 3-1/2" HHCS (Item #2) and (4) 3/8"-16 Ny-flange Lock Nuts (Item #3). Refer to Figure A.

Note: Some part features have been hidden for visual clarity.

Figure A

Item #	Part #	Desc.	Qty.
1	A2207	Receiver Tube Assy. / Mount Arm	1
2	K1200	3/8"-16 x 3.5" HHCS G5	4
3	K2038	Ny-Flange Lock Nut 3/8"-16	4

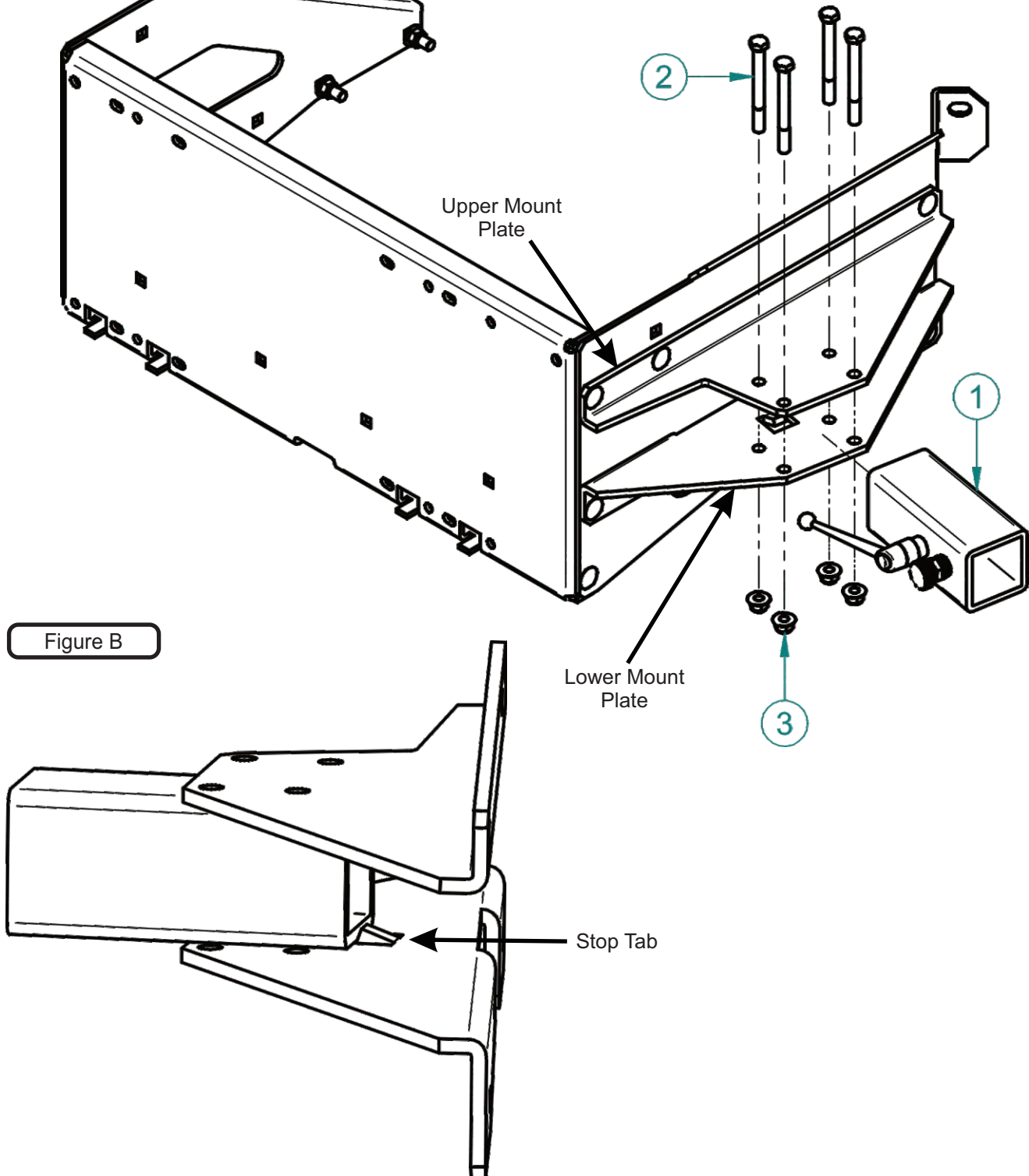
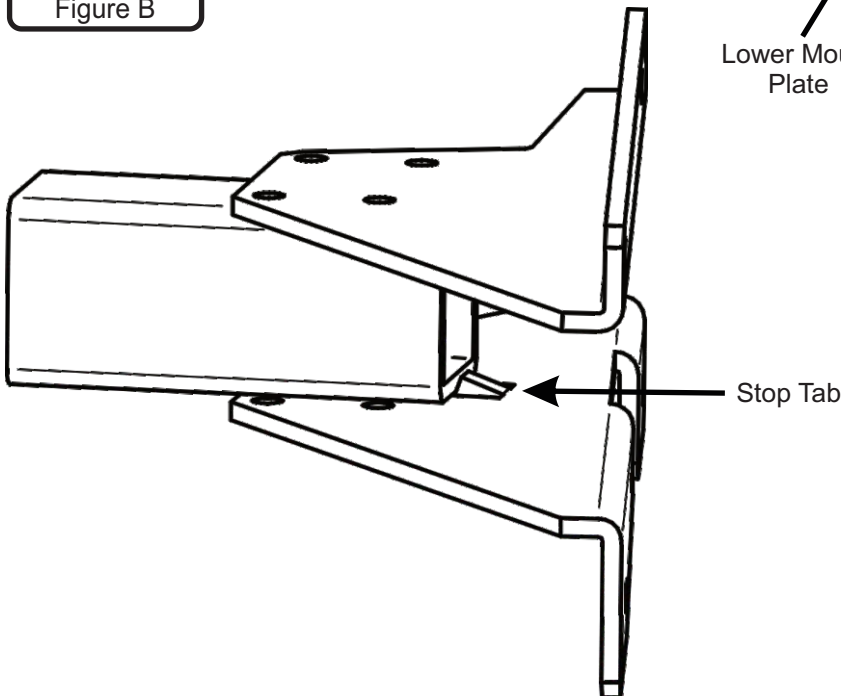

Figure B



Main Frame Mount Installation

Align either the Right Main Frame Mount (Item #1) or the Left Main Frame Mount (Item #2) to the Mount Plates. Make sure the bolt holes of either Main Frame Mounts are aligned to those on the Rear Mount Plate and either Right or Left Mount Plate. Secure either Main Frame Mounts to the Mount Plates by using (2) 3/8"-16 x 1" Carriage Bolts (Item #3) and (2) 3/8"-16 Ny-Flange Lock Nuts (Item #4) PER side. Refer to the Figure below.

Keep all hardware during this step relatively loose for the installation of the Main Frame Assembly.

Note: Some part features have been hidden for visual clarity.

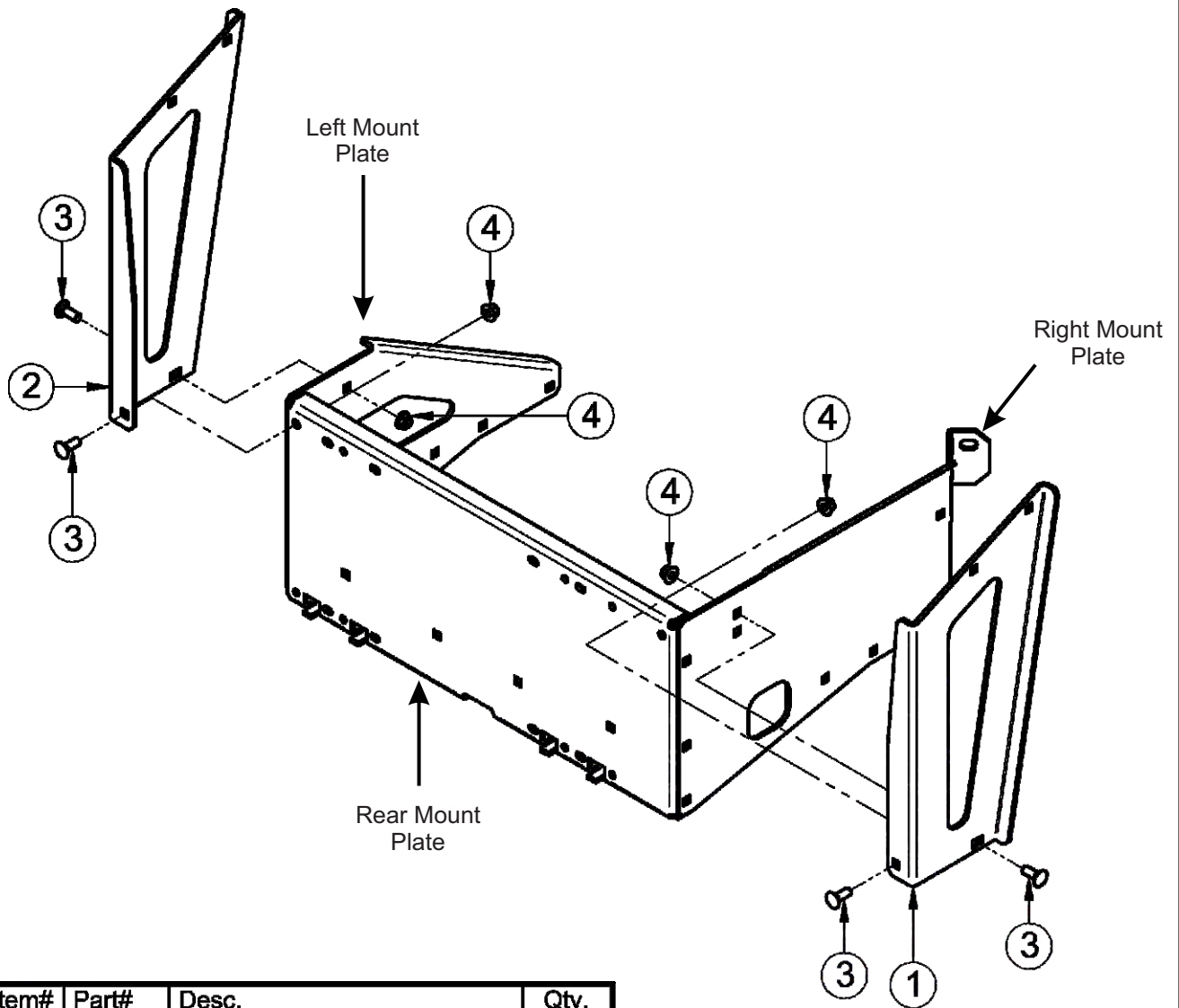

Item#	Part#	Desc.	Qty.
1	B1095	Right Main Frame Mount	1
2	B1096	Left Main Frame Mount	1
3	K1182	Carriage Bolt 3/8"-16x1"	4
4	K2038	Ny-Flange Lock Nut 3/8"-16	4

Main Frame Assembly Installation

Align the bolt holes of the Main Frame Assembly (Item #1) to those on the Left and Right Main Frame Mount. Be sure the Main Frame Assembly is sitting on the inside of both Main Frame Mounts. Secure the Main Frame Assembly by using (2) 3/8"-16 x 1" Carriage Bolts (Item #2) and (2) 3/8"-16 Ny-Flange Lock Nuts (Item #3) PER side. Refer to the Figure below.

Tighten all hardware at this time.

Note: Some part features have been hidden for visual clarity.

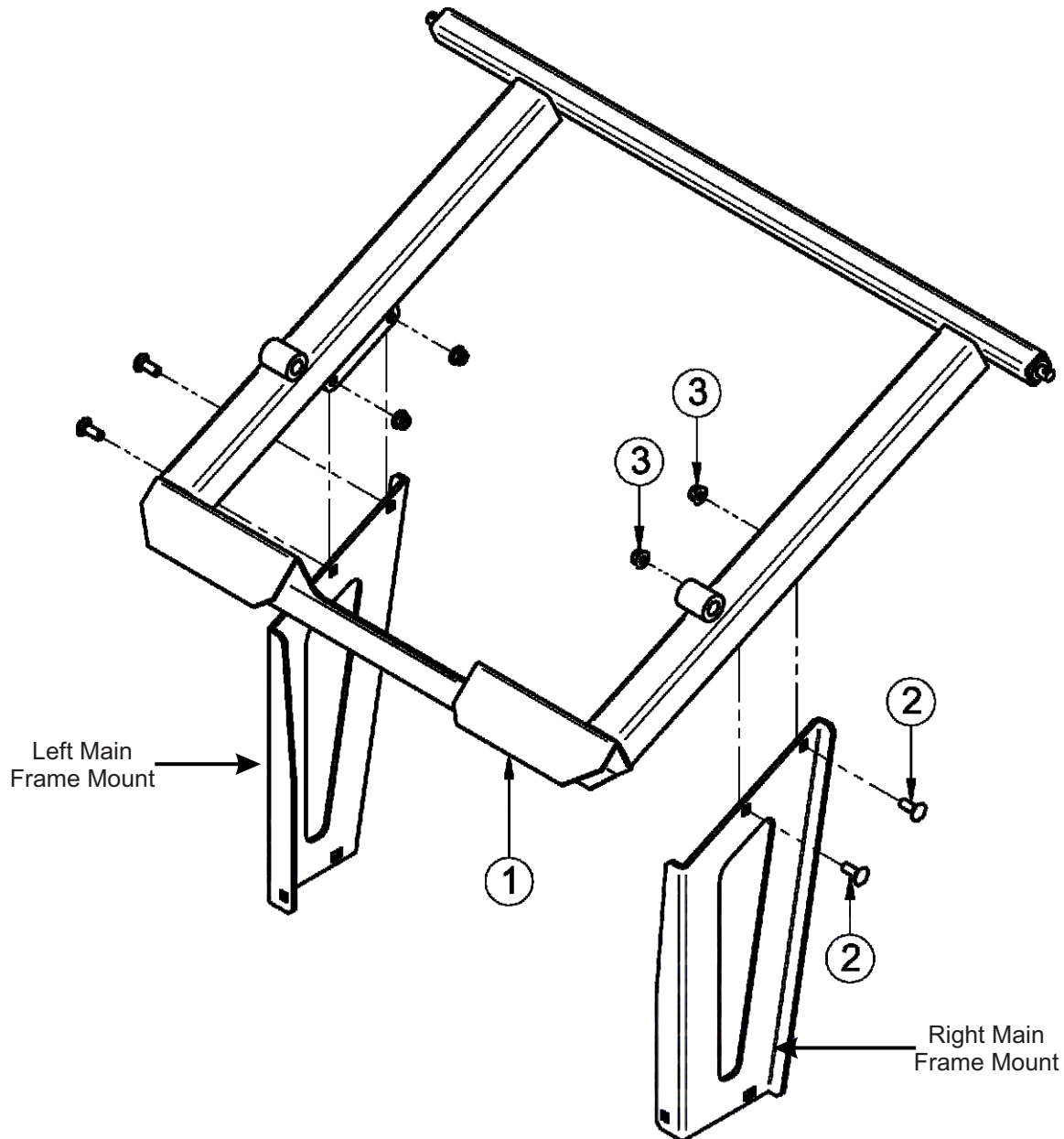

Item#	Part#	Desc.	Qty.
1	A1192	Main Frame Assembly	1
2	K1182	Carriage Bolt 3/8"-16x1"	4
3	K2038	Ny-Flange Lock Nut 3/8"-16	4

PTO Drive Assembly

Once the Mount Arm Assembly is installed and secured to the mower, assemble the Drive Assembly P#(A2061_01), Belt Guard Assembly P#(A2069_02) & Idler Mount Assembly P#(A2067_02).

First, attach the Belt Guard Assembly P#(A2069_02) to the Drive Assembly P#(A2061_03) using (2) 1/4"-20 x 5/8" Carriage Bolts P#(K1010) and (2) 1/4"-20 Ny-Flange Lock Nuts P#(K2014). Refer to Figure A. **Leave Bolts Loose.**

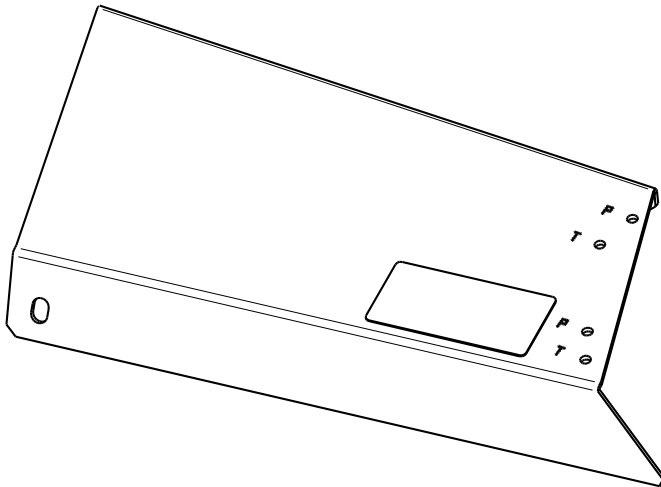

BELT GUARD ASSY. HOLES

Notice Marked Holes Below;
For This Installation, Use Holes
Marked With The Letter 'P'

Figure A

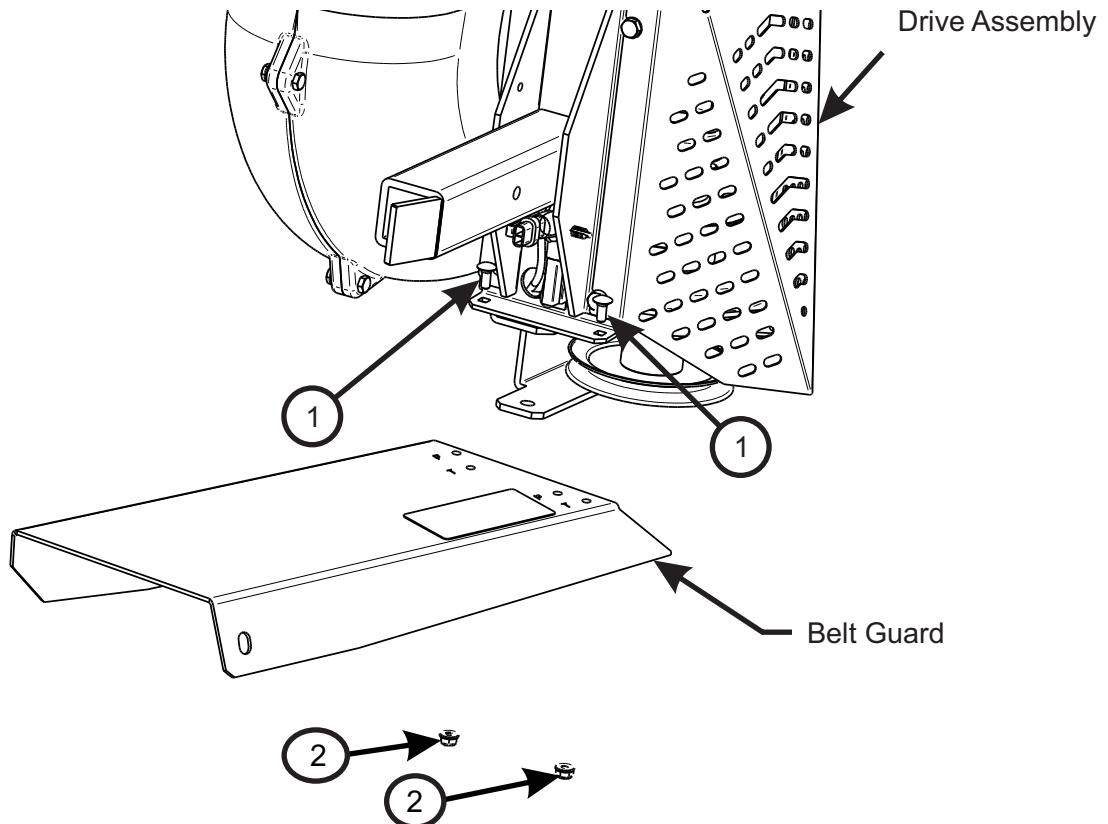

Item #	Part #	Desc.	Qty.
1	K1010	1/4"-20 x 5/8" Carriage Bolt	2
2	K2014	1/4"-20 Ny-Flange Lock Nut	2

PTO Drive Assembly (Continued)

Attach the Idler Mount Assembly P#(A2067_02) to the Drive Assembly using (1) 3/8"-16 x 1" HHCS (A) P#(K1191), (1) 3/8"-16 x 1" Carriage Bolt (B) P#(K1182) and (2) 3/8"-16 Ny-Flange Lock Nuts P#(K2038). Refer to Figure B. Leave Bolts Loose (Note: Orientation of bolts A & B.)

Next, secure the Idler Mount Assembly P#(A2067_02) to the Belt Guard Assembly P#(A2069_02) using (2) 3/8"-16 x 1" Carriage Bolts P#(K1182) and (2) 3/8"-16 Ny-Flange Lock Nuts P#(K2038). Refer to Figure C & D. Tighten All Bolts.

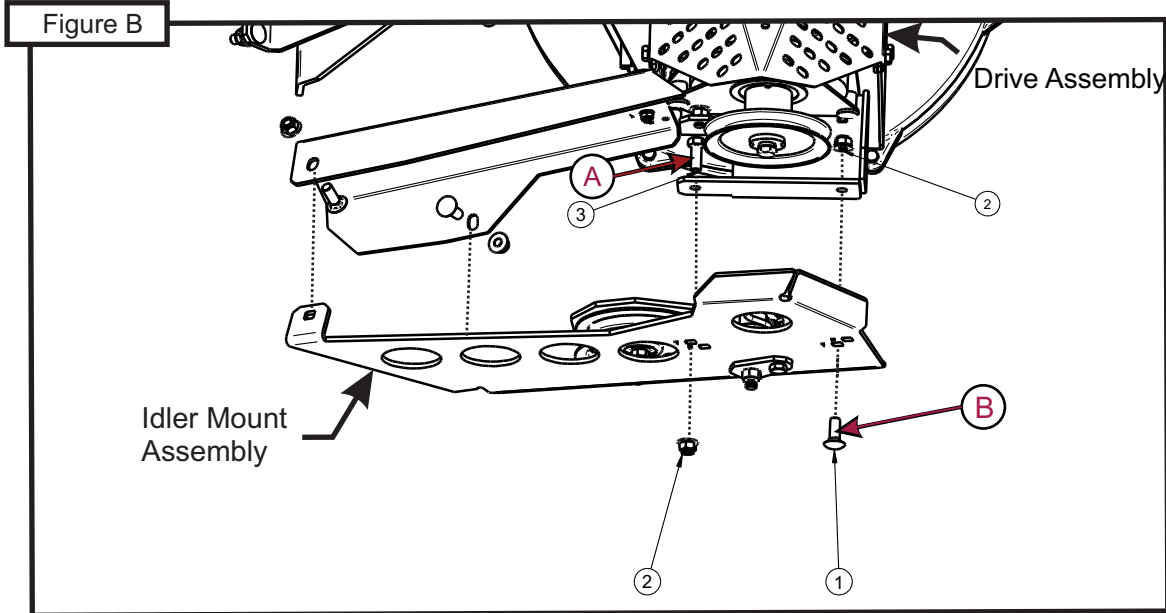

Item #	Part #	Desc.	Qty.
1	K1182	Carriage Bolt 3/8"-16 x 1"	1
2	K2038	Ny-Flange Lock Nut 3/8"-16	2
3	K1191	HHCS 3/8"-16 x 1" GR5	1

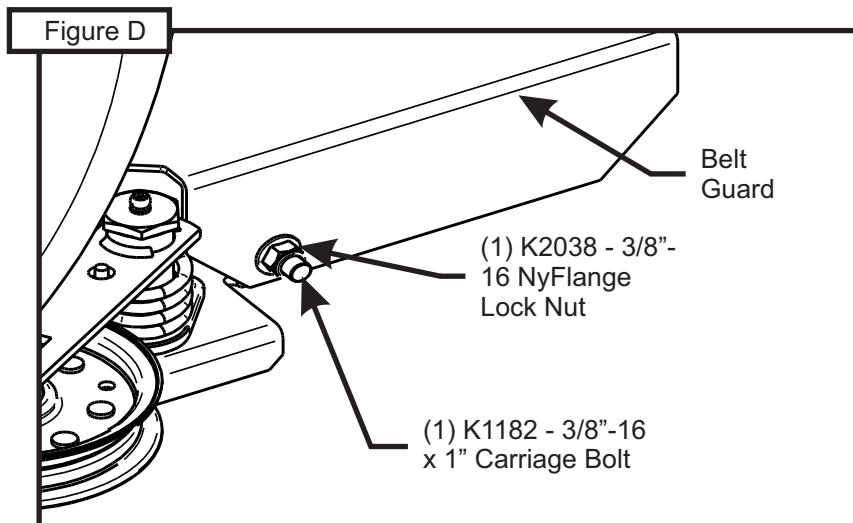
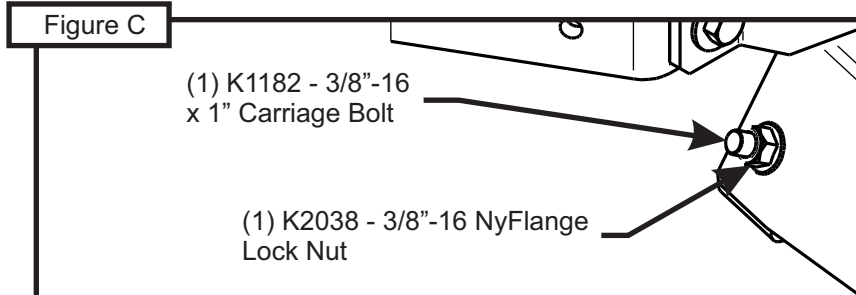

Drive Assembly and Belt Installation

(Note: It is recommended that someone assist during this step.)

Insert the Drive Assembly into the receiver tube on the Mount Arm Assembly until the Knob Plunger Pin engages. Once in place, turn Lock Handle clockwise until tight. Next, feed the AK83 Belt P#(M0315) between the Belt Guard and the Idler Mount Assembly. Place belt around the Engine Drive Pulley on the underside of the mower. While one person inserts a screw driver (or similar tool) into the Idler Mount Assembly and rotates lever arm clockwise, enough to relieve all tension from belt, place belt around the Drive Assembly Pulley. Once the belt is in position, carefully release the tension to tighten belt.

Refer to the images below.

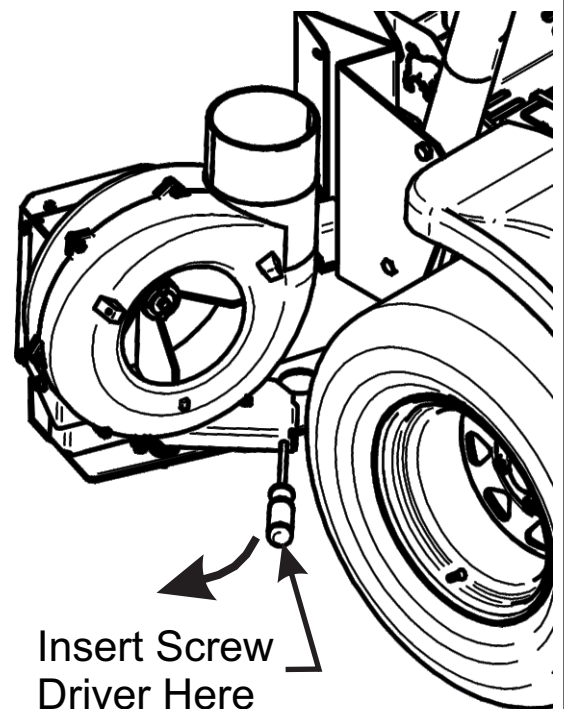
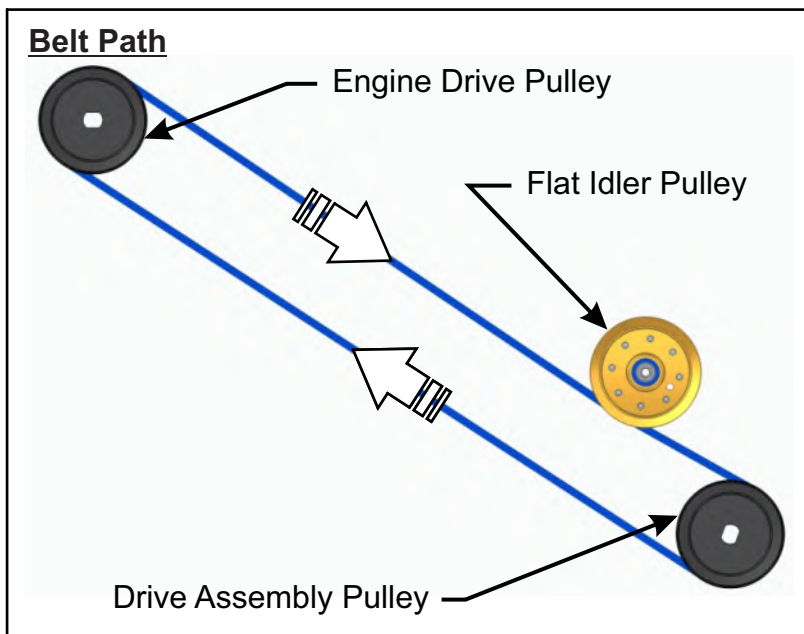
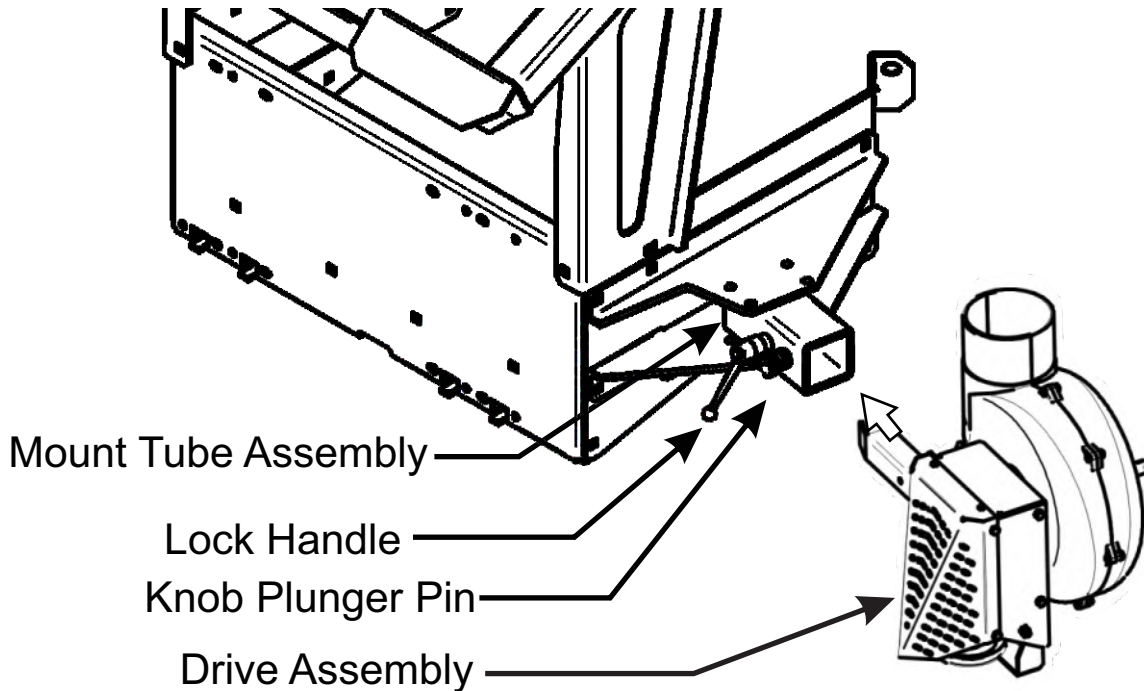

Boot Kit Installation

Step 1 - Remove the mower's Operator Controlled Discharge Chute (OCDC) and attach the Boot Plate Adapter (Item #7) to the far right mounting hole as shown in Figure B using (1) 3/8"-16 x 1" Hex Head Cap Screw (Item #8), (1) 3/8" Flat Washer (Item #9) and (1) 3/8"-16 Ny-Flange Lock Nuts (Item #6).

Step 2 - Secure the Boot Plate (Item #2) to the Aluminum Boot (Item #1) using (2) 3/8"-16 x 1" Carriage Bolts (Item #5) and (2) 3/8"-16 Ny-Flange Lock Nuts (Item #6). Insert the Carriage Bolts from the inside of the Boot so the threads are on the top of the Boot. This will prevent grass clippings from collecting on the threads. Leave the hardware loose until the boot plate has been attached to the mower deck.

Step 3 - Align Boot Plate Bushings to the Boot Plate Adapter Bushings.

Step 4- Insert Boot Rod (Item #3) through the Boot Plate Adapter & Boot Plate Bushings.

Step 5 - Secure the Boot Rod using a Hair Pin Clip (Item #4).

Step 6 - With the Carriage Bolts (Item #5) still loose, adjust the position of the boot so that there is no gap between the mower deck and the boot.

Step 7 - Tighten all hardware at this time.

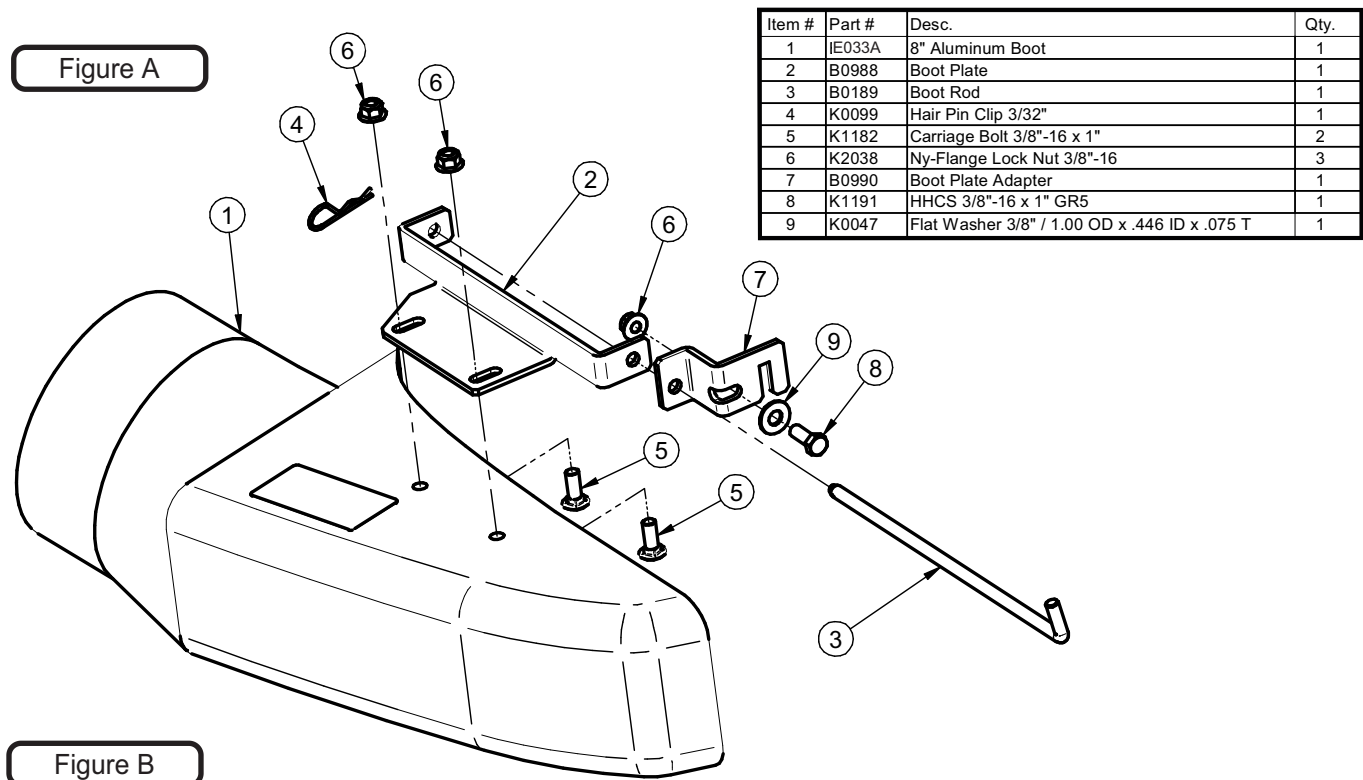

Lift Handle Installation

NOTE: Before continuing the Lift Handle installation, have someone assist you in turning the Box Assembly upside down. Insert (1) 3/8"-16 x 2" HHCS P#(K1208) into the Lift Handle P#(A0897), and secure with (1) 3/8"-16 Flange Nut P#(K1215). Thread the flange nut onto the bolt upside down, as shown in Figure A. Do not tighten the nut fully at this time.

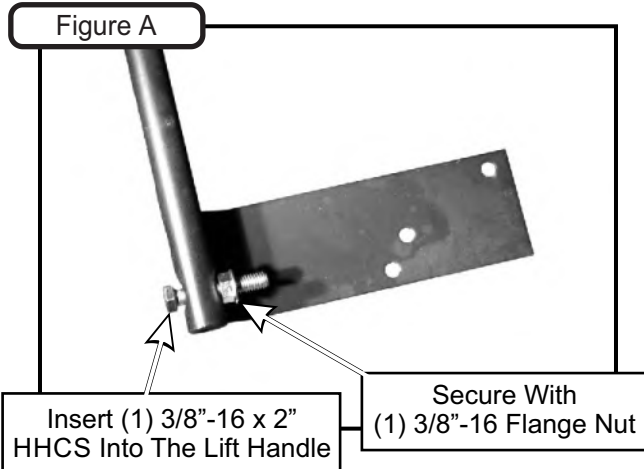

Slide the Lift Handle through the slot on the Handle Mount Bracket. Insert the Lift Handle into the Box Frame as shown in Figure B, and secure using (1) 3/8"-16 Flange Nut P#(K1215) on the inside of the Box as shown in Figure C. Now test the movement of the handle. It should have full-range of movement in the slot. If the handle does not have full-range of movement, adjust the 3/8"-16 Flange Nut from step A. Once achieved, tighten the fasteners.

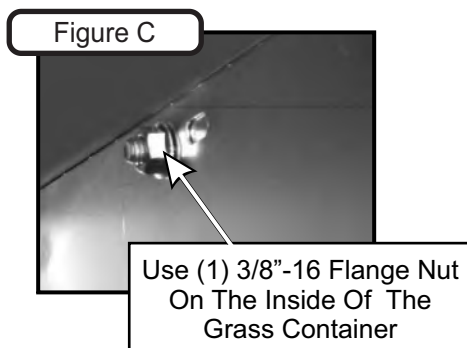
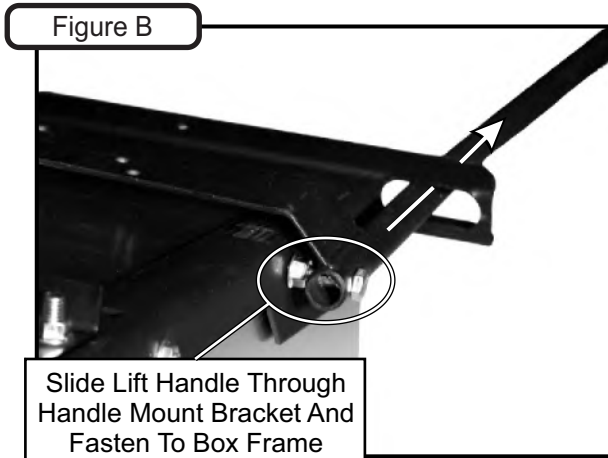

Fasten the Ball Joint P#(K1442) to the end of the Latch Rod P#(A2107). Tighten the Ball Joint to approximately half-way down the threads on the Latch Rod. Attach the Ball Joint to the Latch Hook as shown in Figure D, using (1) 5/16"-24 Hex Nut P#(K1444) and (1) 5/16" Lock Washer P#(K0043).

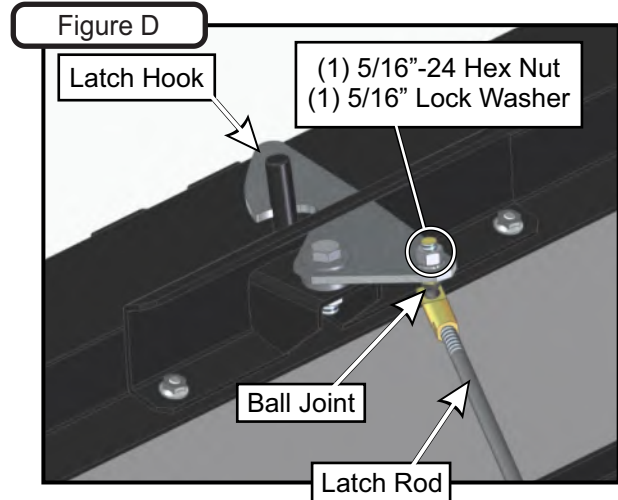

Attach the other end of the Latch Rod to the Lift Handle, as shown in Figure E. Attach one end of the Spring P#(J0176) to the Lift Handle and the other end of the Spring to the Handle Mount Bracket as shown in Figure F. Adjust the Ball Joint up or down on the Latch Rod threads until the Latch Hook closes completely. After adjusting the Latch Hook, secure the Latch Rod to the Lift Handle using (1) Cotter Pin P#(K0094).

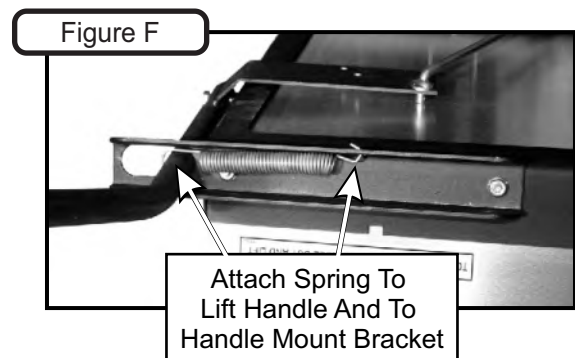
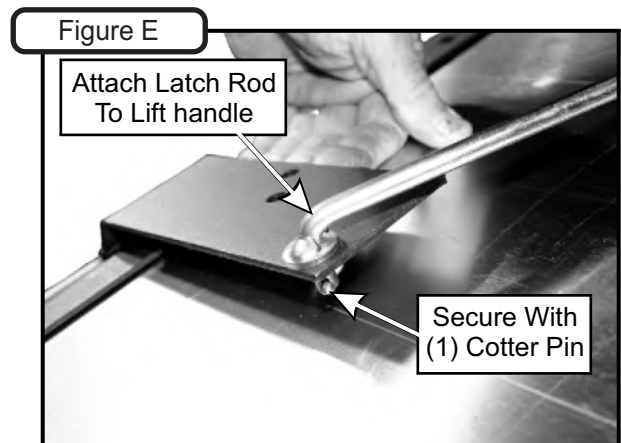

Aluminum Box Assembly Installation

NOTE: It is recommended that two extra people assist in mounting the Box Assembly. Two can lower the Box onto the frame while the third person inserts the Pivot Pins P#(K0172) through the holes. Insert the Pins from the outside to the inside. Secure with (1) 5/8" Washer P#(K0058) and (1) 5/32" x 2-5/8" Hair Pin Clip P#(K0088) per Pivot Pin (Figure B). Reattach the bottom ends of the door opening linkages to the Main Frame by using (1) Rue-Ring Cotter Pin P#(K1437) per side. To test the functionality of the dump mechanism, pull the Lift Handle away from the unit, and lift upward. The Door of the Box Assembly should open and the Box should pivot clockwise towards the ground.

Figure B

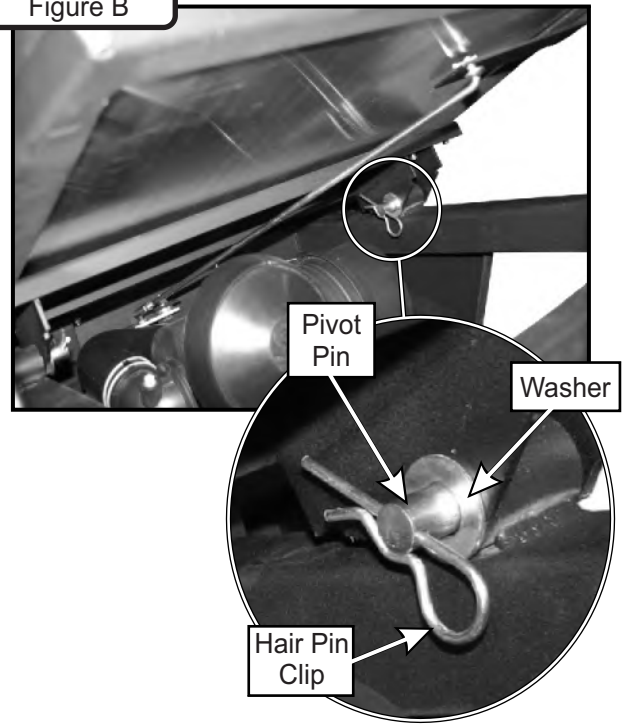
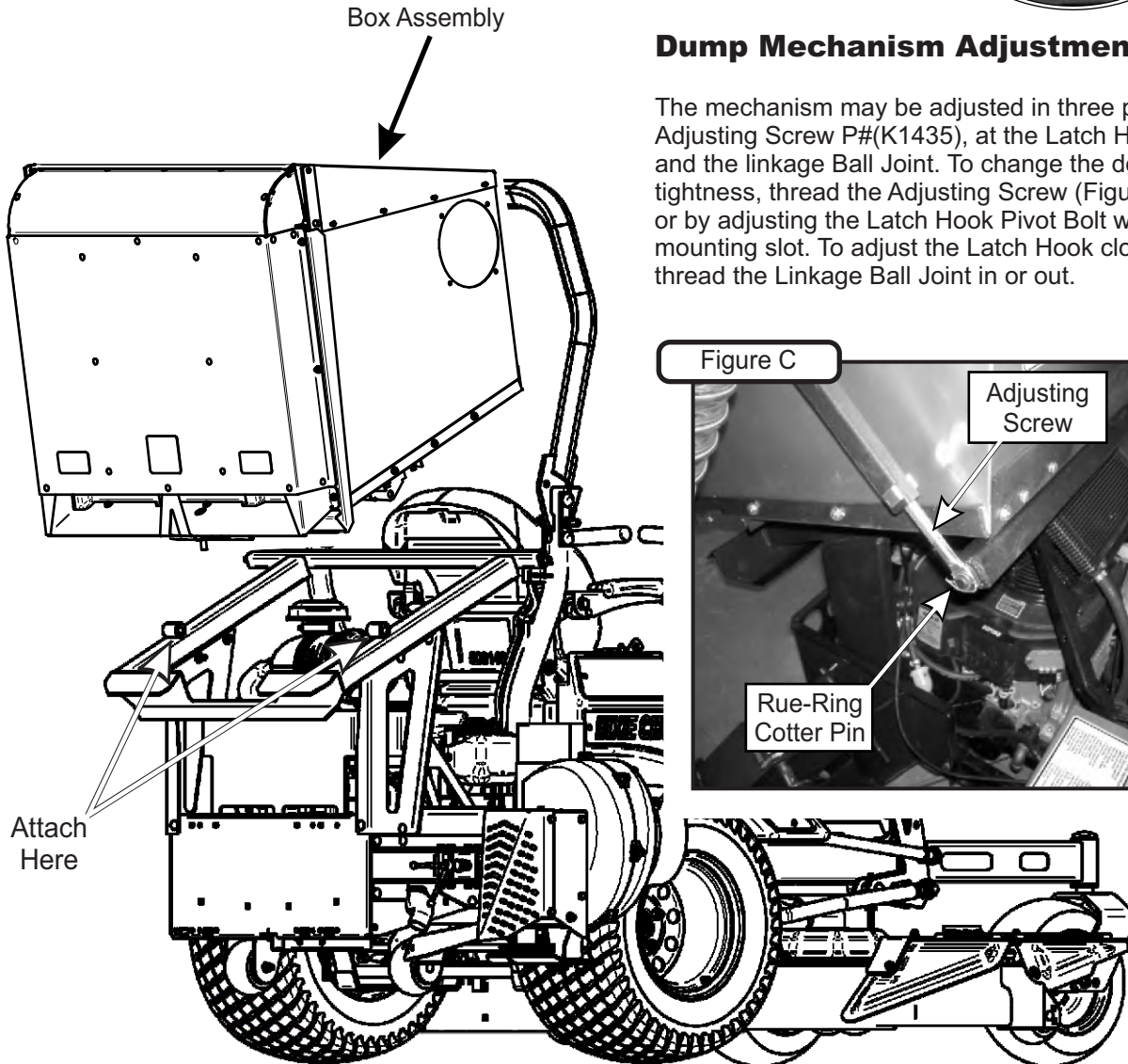

Figure A



Dump Mechanism Adjustment

The mechanism may be adjusted in three places, at the Adjusting Screw P#(K1435), at the Latch Hook Pivot Bolt and the linkage Ball Joint. To change the door closure tightness, thread the Adjusting Screw (Figure C) in or out or by adjusting the Latch Hook Pivot Bolt within its' mounting slot. To adjust the Latch Hook closure angle, thread the Linkage Ball Joint in or out.

Figure C

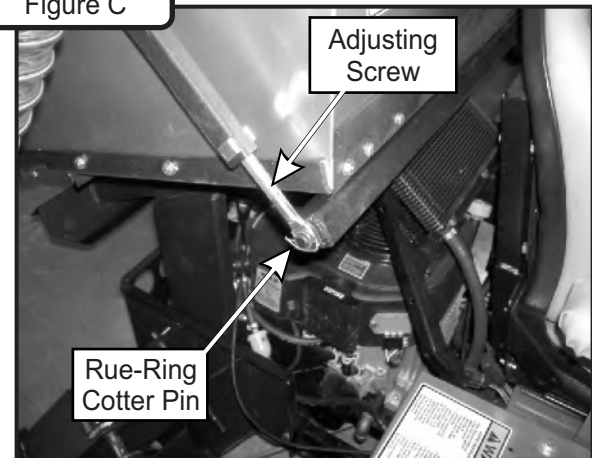

Inlet, Inlet Ring & Debris Deflector Installation

Open box door. From inside box, slide Inlet (Item #3) halfway into inlet hole (See Figure A). Take each half of the Inlet Ring (Item #1) and attach around matching groove in Inlet (Item #3). Slide Inlet (Item #3) & Inlet Ring (Item #1) against inlet hole and align four holes. Fasten Inlet Ring (Item #1) bottom holes using (2) 5/16" IT Tooth Lock Washers (Item #4) & (2) 5/16"-18 x 1/2" HHCS (Item #6) (See Figure B). Fasten Inlet Ring (Item #1) top holes using (2) 5/16" IT Tooth Lock Washers (Item #4) & (2) 5/16"-18 x 1-1/4" HHCS (Item #5). Slide Debris Deflector (Item #2) over inside top bolt threads (Item #5). Fasten Debris Deflector (Item #2) using (2) 5/16"-18 Ny-Flange Lock Nuts (Item #7). Final assembly should resemble Figure C.

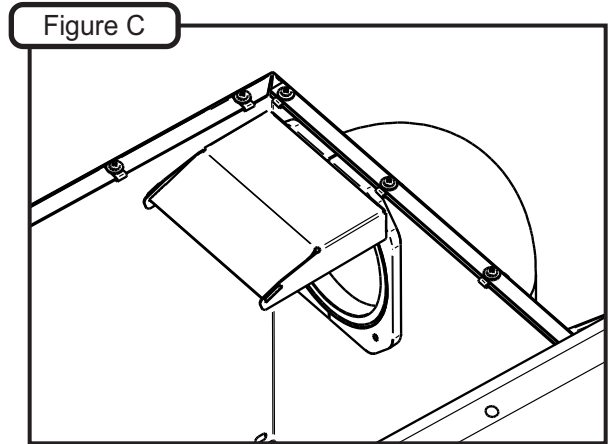
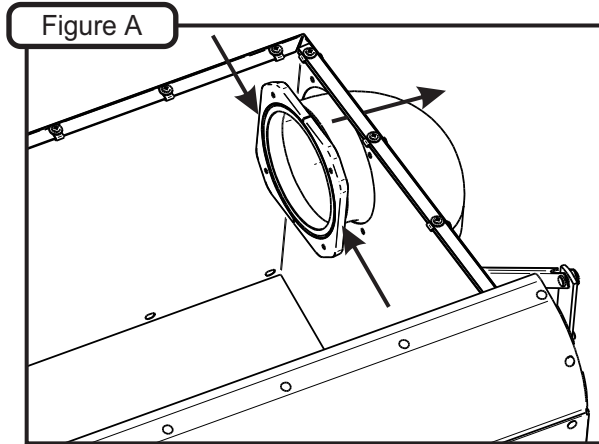
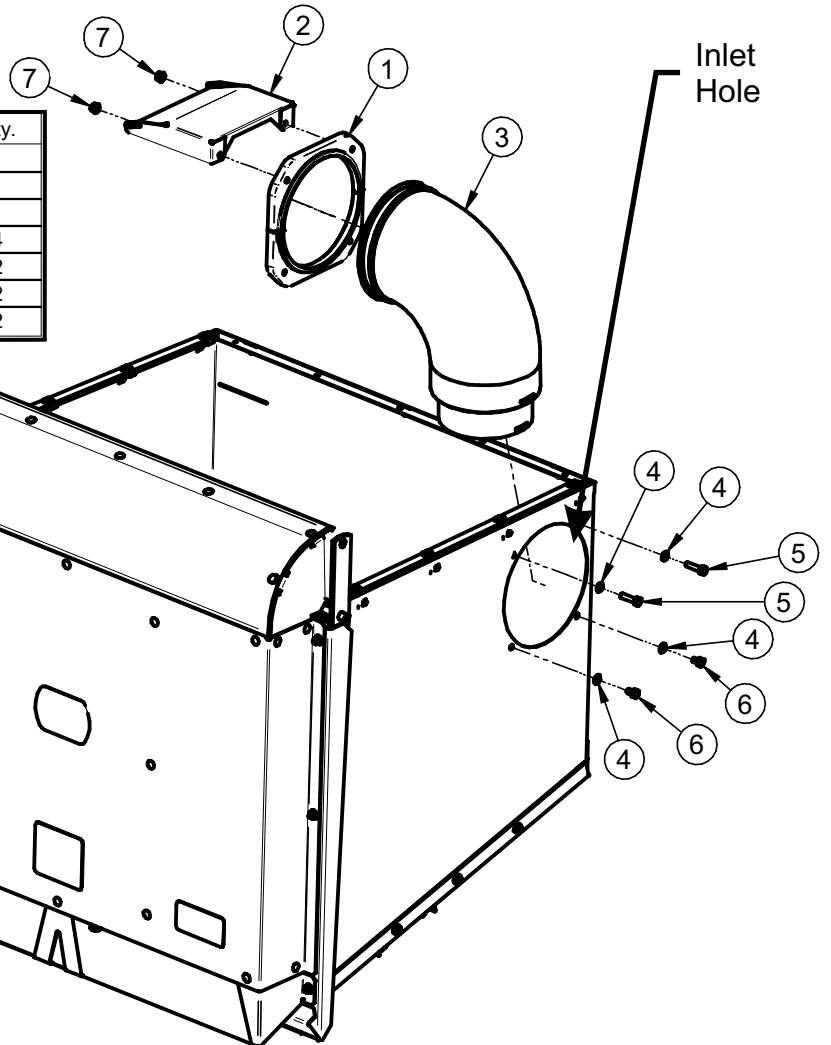

Figure B

Item #	Part #	Desc.	Qty.
1	C0074	Inlet Ring	1
2	C0088	Debris Deflector	1
3	V0025	Universal Inlet / 6" & 7"	1
4	K0044	I/T Tooth Lock Washer 5/16"	4
5	K1156	5/16"-18 x 1-1/4" HHCS	2
6	K1152	HHCS 5/16"-18 x 1/2"	2
7	K2516	Ny-Flange Lock Nut 5/16"-18	2



Open Box Door
To Assemble Inlet,
Inlet Ring & Debris
Deflector

Note: Box Top & Screen Removed
In Figure Above For Visual Clarity.

Wiring Harness Installation



WARNING

**To Prevent Serious Injury-
Proper Installation Of Safety Interlock Harness
Is Mandatory. Please Check That All Interlock
Points Work Correctly Once Installed.**

Route the 2 Way Metri-Pack Connector (P#P0280) around the right side of the engine and down between the side of the ROPS to the right of the Right Mount Plate connecting the Quick Connect Plug (#1) located on the PTO Drive. Refer to Figure A.

Attach the Positive Lead from the Wiring Harness (P#A2144) connected to the Metri-Pack 2 Way Connector (P#P0280) to the PTO Switch (P#J2001) by connecting the Female Disconnecter (P# P0106) from the Positive Lead to the Switch Terminal (A) on the Switch. Refer to Figure B on the next page.

Insert the PTO Switch in and through the PTO Switch Bracket (P#B1020) then attach and secure the Safety Cover (P#P0073).

Before routing the PTO Switch (#2), locate and loosen the existing cap head screw located on the bottom right side of the mower's control panel. Attach the PTO Switch Bracket by sliding it behind the cap head screw and tightening the screw. Refer to Figure A. (Note: This is the recommended positioning of the PTO Switch, the PTO Switch could be mounted anywhere within reasonable distance and clearance to the right of the operator's seat)

Route the PTO Switch to the positive terminal of the battery (#3) using the Ring Terminal (P#P0086) of the Positive Lead to secure the attachment. Route the Negative Lead to the engine block (#4) using the Ring Terminal of the Negative Lead to secure the attachment. Refer to Figure A.

Use the zip ties (P#J0245) that are provided to secure the wires in place.

Figure A

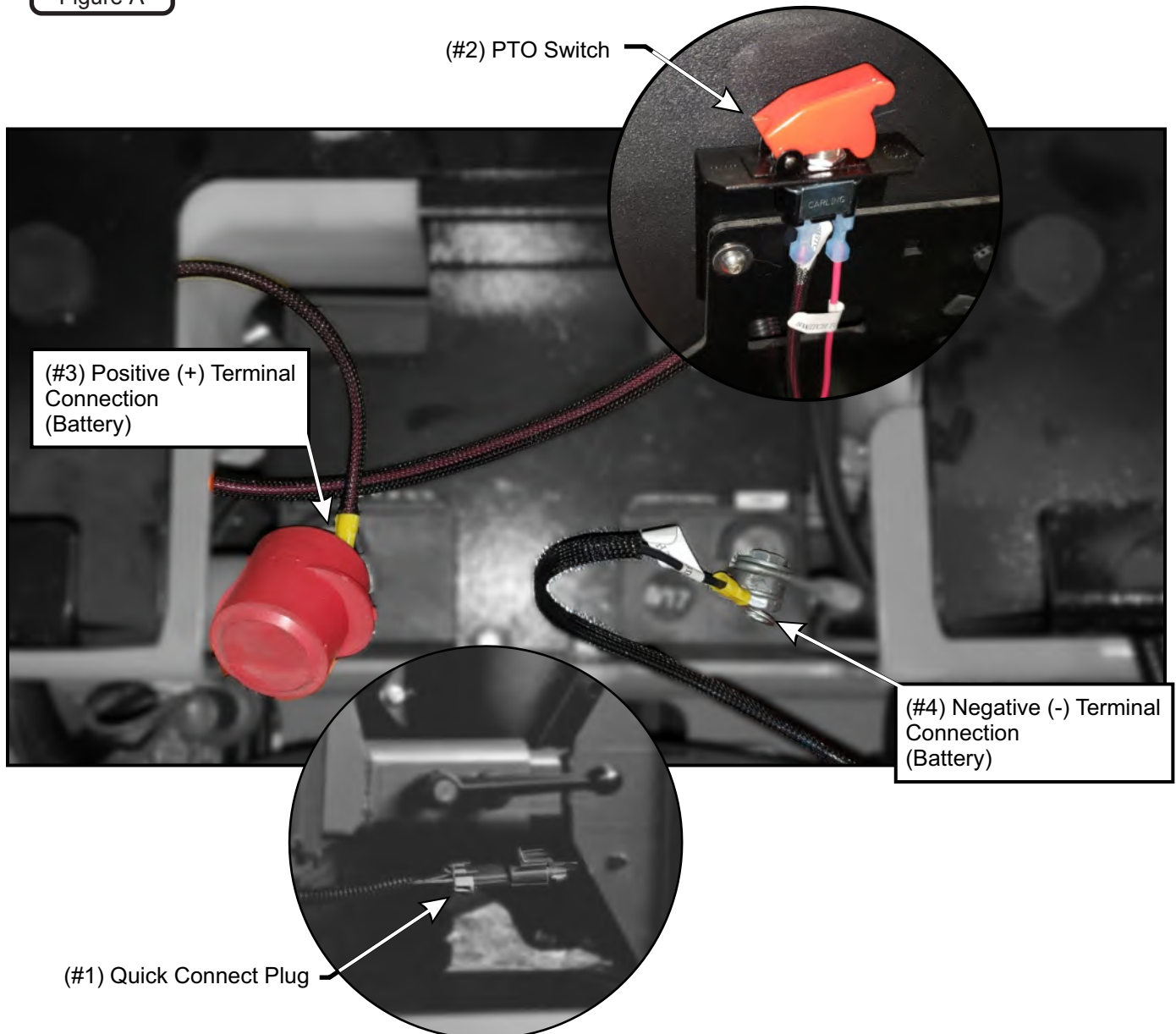

Wire Harness Installation (Continued)

Figure B

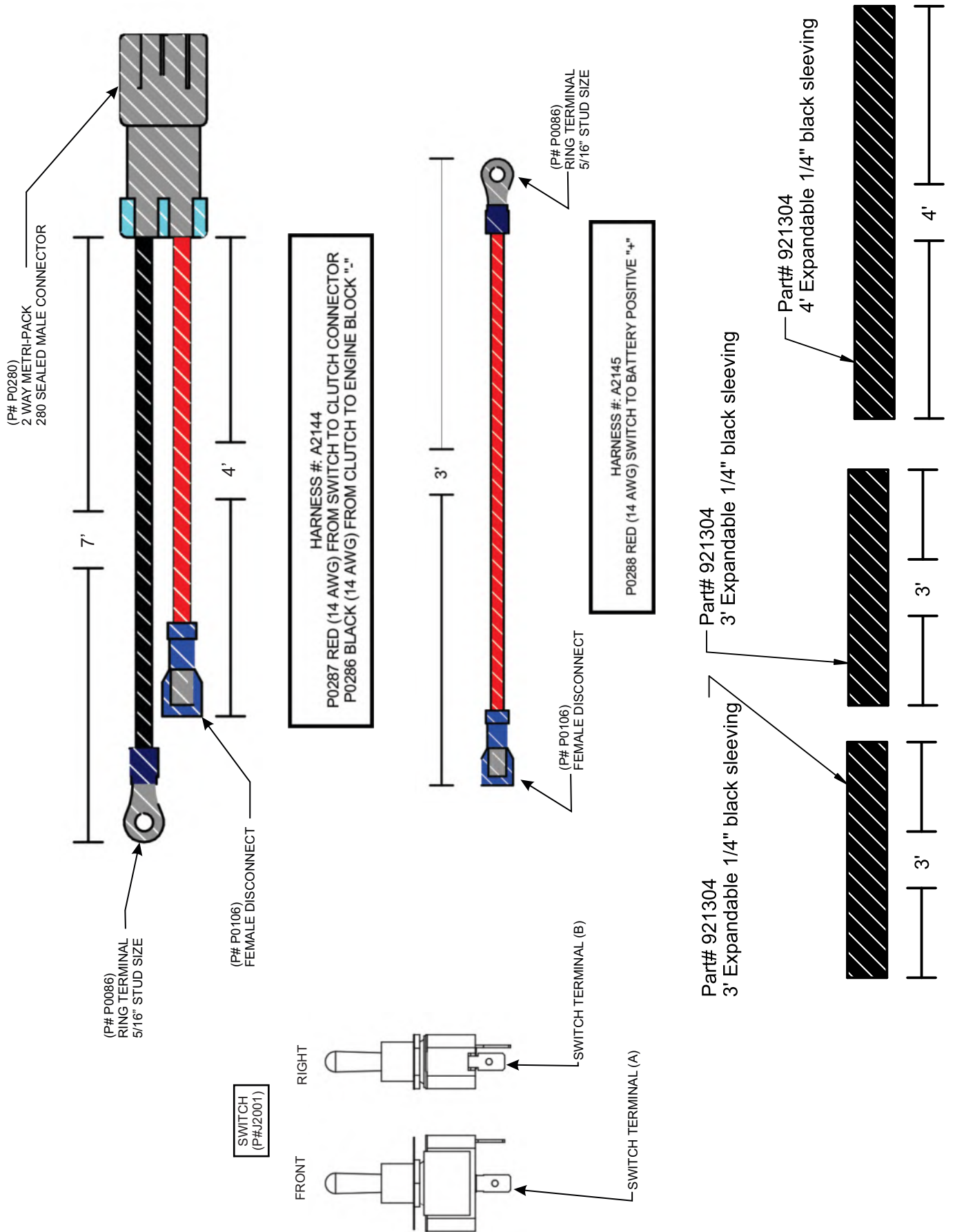

Length Of Hose Adjustment

The hoses in the following steps must be cut to fit your machine. Do not cut the hoses until you have tried to fit them on your machine. Remember that the hoses need to be long enough to allow for the opening and closing of the collection system as well as allowing ample clamping surface between each component.

Upper Hose Installation

Slide a Hose Clamp P#(J0060) over one end of the 6" Upper Hose. Secure this end of the 6" Upper Hose to the Blower Outlet. See Figure below for details. Secure opposite end of the 6" Upper Hose to the Inlet with another Hose Clamp P#(J0060). Make sure both ends are securely fastened by tightening the Hose Clamp.

Lower Hose To Blower Cone Installation

Slide a Hose Clamp P#(J0080) over both ends of the Lower Hose. Secure one end of the Lower Hose to the Blower Cone and fasten by tightening the Hose Clamp.

Lower Hose To Boot Installation

Take the unattached end of the Lower Hose and secure it to the circular end of the Boot and fasten by tightening the Hose Clamp.

Tip: Before securing Hose Clamp fully, rotate Lower Hose counter-clockwise (away from yourself) approximately 1" to aid in retaining Boot to mower deck.

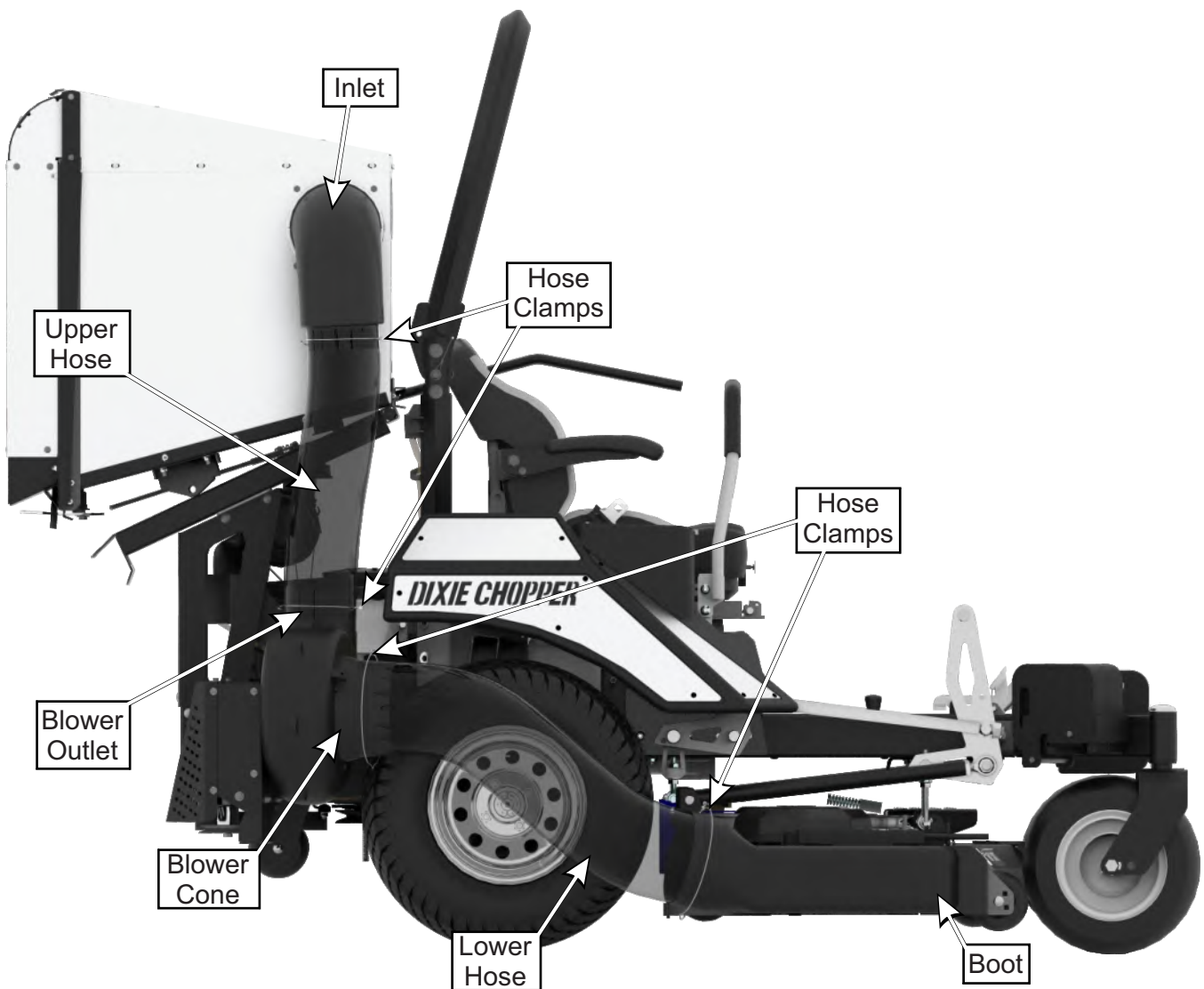

Impeller Blade Removal/Replacement

To Remove: First remove the 5/16"-24 x 1" HHCS P#(K0428) (#1), Taper Lock Bushing Washer P#(K0284) (#3), (2) 5/16 Flat Wahers P#(K0042) and Spacer Bushing P#(S0159) (#4) from the Taper-Lock Bushing P#(S0157) (#5). Next remove the (2) 1/4"-20 x 1" HHCS (#2) and place them into the threaded holes of the Taper-Lock Bushing (#5). Gradually thread each bolt evenly into the Taper-Lock Bushing, forcing the blade to break-away from the Taper-Lock Bushing. If the Impeller will not move, carefully hit the base of the Impeller, between each vein, with a hammer, then try again.

To Replace: Place Impeller Blade over the engine shaft. Slide the Taper-Lock Bushing (#5) on to the engine shaft and into the Impeller Blade, aligning the **non-threaded** holes of the Taper-Lock Bushing to the threaded holes of the Impeller Blade. Fasten by using (2) 1/4"-20 x 1" HHCS (#2), (1) Spacer Bushing (#4) (1) Taper-Lock Bushing Washer (#3), and (1) 5/16"-24 x 1" HHCS (#1). Torque to the proper specifications in the torque chart on the back of this manual. Next, rotate the Impeller Blade to ensure that the blade is clear of contact on all sides of the blower housing.

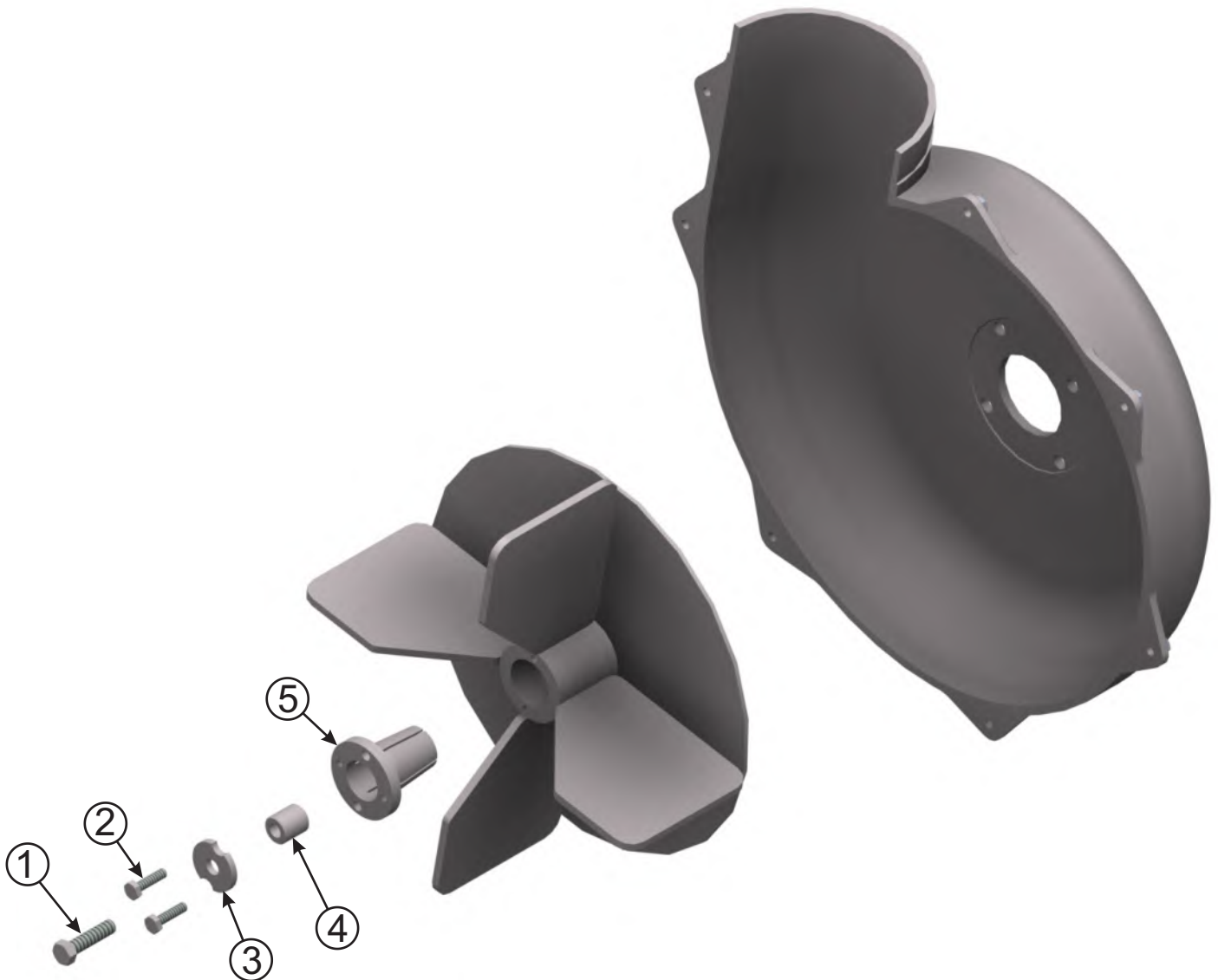

Weight Kit Installation

Remove the existing front name plate by removing the top two screws and bottom two screws. Refer to Figure A. Remove the footrest to expose (4) large carriage bolts and nuts, located behind the name plate. Remove and keep (2) existing nuts from the existing carriage bolts, (1) from the far lower left and (1) from the far lower right. Refer to Figure B. Place Weight Bracket (#1) over the front of the mower and under the footrest as shown in Figure B. Replace and tighten the (2) nuts removed earlier to the existing carriage bolts.

Figure A

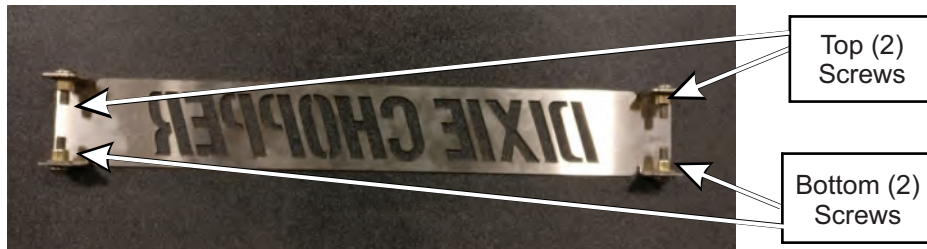

Figure B



Insert (2) Suitcase Weights (#2) per side onto the weight bracket & align the holes of the Suitcase Weights to the holes of the Weight Bracket. Secure each set of (2) Suitcase Weights by using (1) Hitch Pin (#3) and (1) Hair Pin Cotter (#4).

Figure C

Item #	Part #	Desc.	Qty.
1	B0989	Weight Bracket	1
2	Y0025	28 lb. Suitcase Weight	4
3	A0312	Hitch Pin Weldment	2
4	K1478	Hair Pin Cotter / Double Loop	4

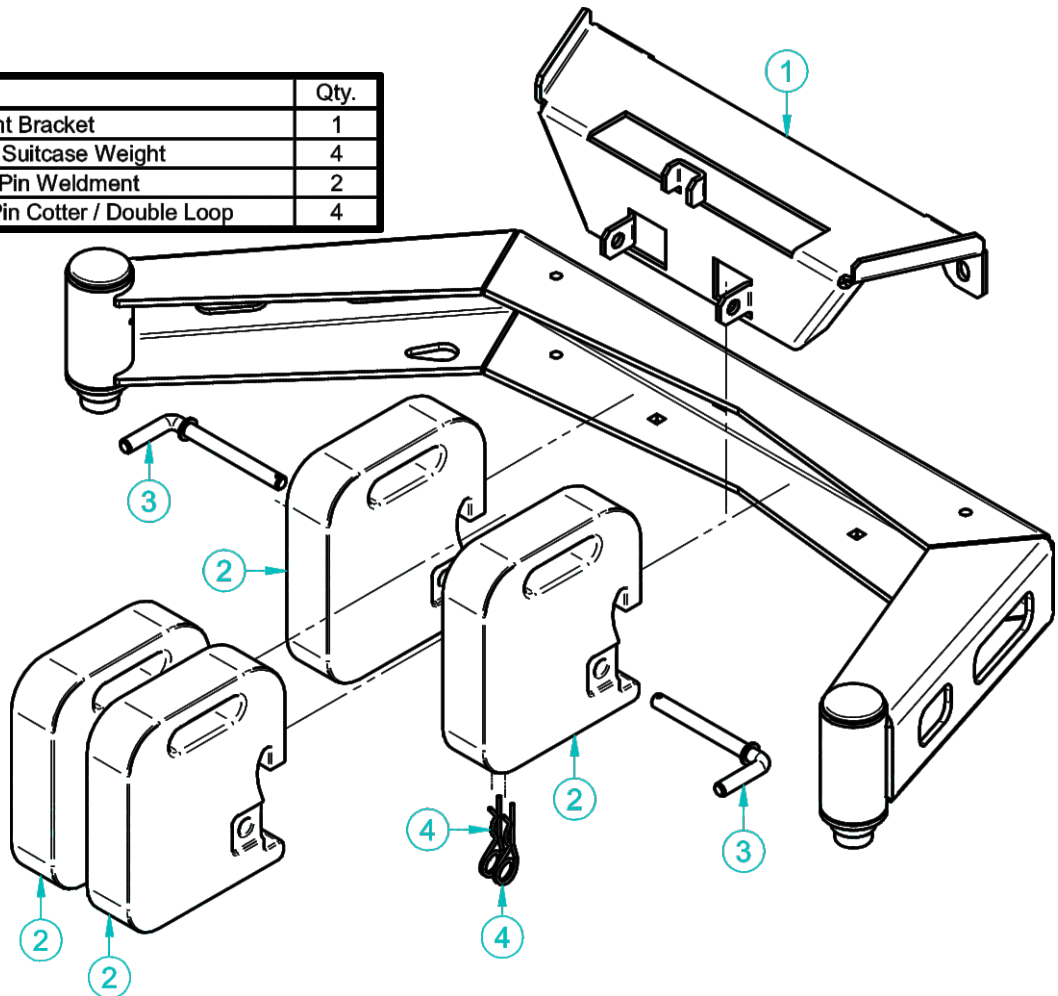

Weight Kit Installation (Continued)

Position and align the Caster / Weight Bracket Support (Item #2) to the inside of the right caster of the mower. Refer to Figure D. Next, align the Right Caster / Weight Bracket (Item #1) to the outside of the mower's right caster and secure the Right Caster / Weight Bracket using (3) 3/8"-16 x 1-1/4" Carriage Bolts (Item #3) and (3) 3/8"-16 Ny-Flange Lock Nuts (Item #4). Refer to Figure D.

Figure D

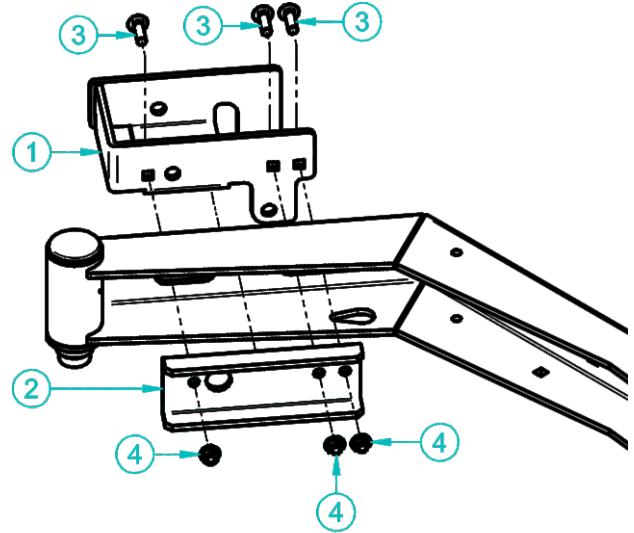
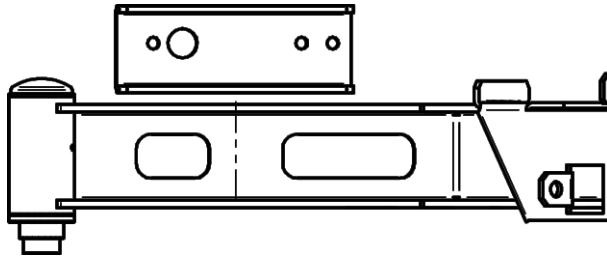

NOTE: Position the bolt holes with the through holes of the Right Caster

Item #	Part #	Desc.	Qty.
1	B1098	Right Caster / Weight Bracket	1
2	B1099	Caster / Weight Bracket Support	1
3	K1183	Carriage Bolt 3/8"-16 x 1-1/4"	3
4	K2038	Ny-Flange Lock Nut 3/8"-16	3

Insert (2) Suitcase Weights (Item #1) into the Right Caster / Weight Bracket and secure the Suitcase Weights using (2) 1/2" x 5" Clevis Pin (Item #2) and (2) Hair Pin Cotter / Double Loop (Item #3). Refer to Figure E.

Figure E

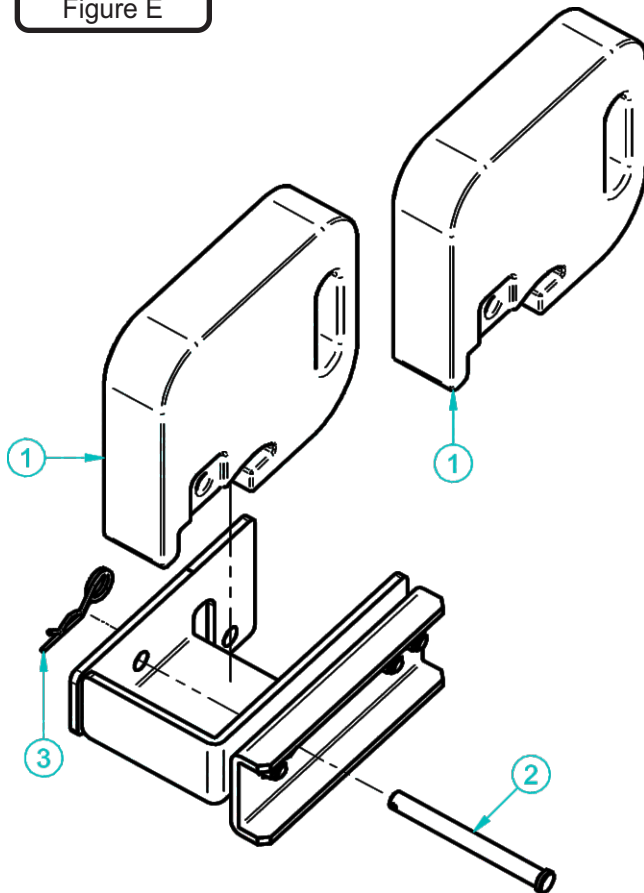

Item #	Part #	Desc.	Qty.
1	Y0025	28 lb. Suitcase Weight	2
2	K1482	1/2" x 5" Steel Clevis Pin	2
3	K1478	Hair Pin Cotter / Double Loop	2

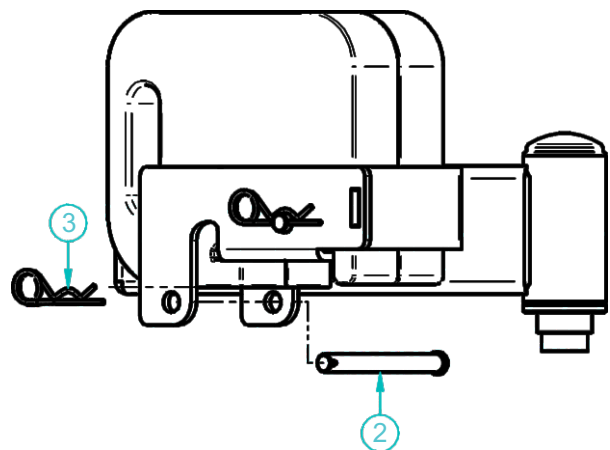

NOTE: The Clevis Pin and Hair Pin Cotter used under the weights are used to lock the weights in place.

A2207 Mount Arm / Tube Assembly Exploded Parts View

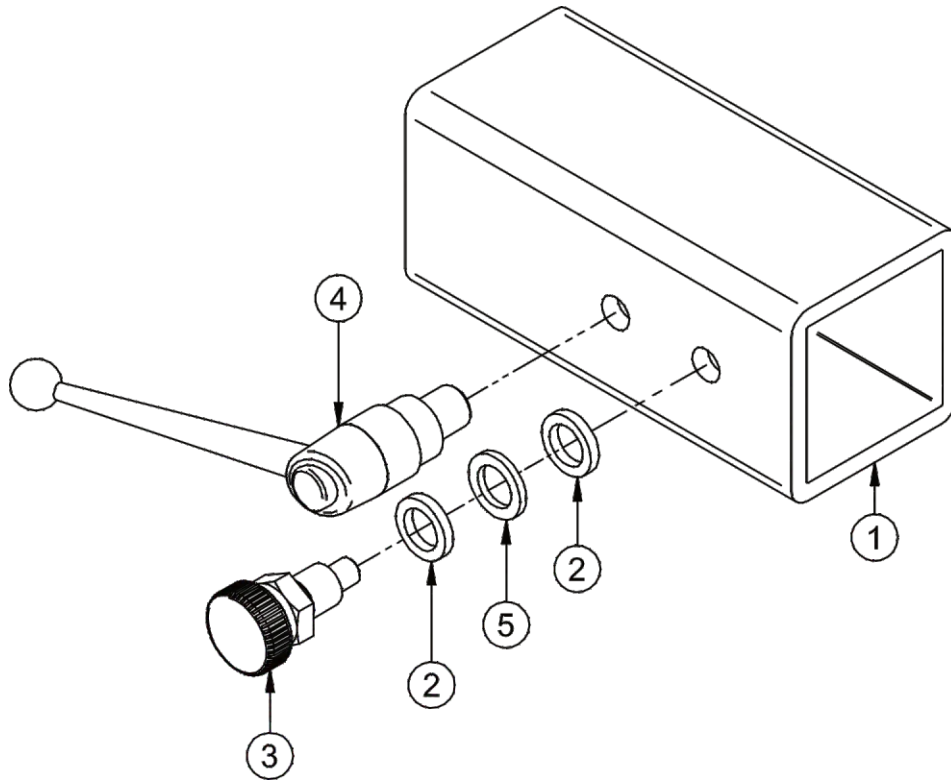

Item #	Part #	Desc.	Qty.
1	B0931	Tube / Mount Arm	1
2	J0013	Nylon Flat Washer 1/2" x .750" OD Grade 6/6	2
3	J0020	Knob Plunger Pin 1/2"-13	1
4	J0009	Adjustable Handle 1/2"-13 x .59 Male	1
5	K0027	Flat Washer 1/2" / .787 OD x .512 ID x .090 T	1

A2092 Idler Arm Assembly Exploded Parts View

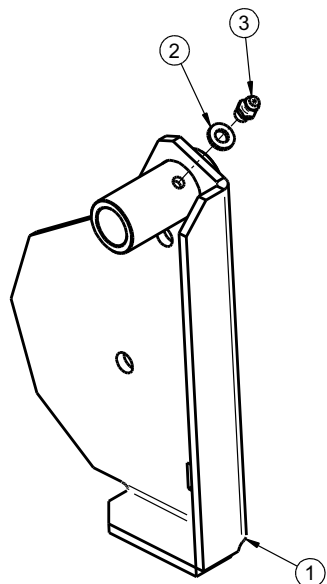

Item #	Part #	Desc.	Qty.
1	A2070_01	Idler Arm Weldment	1
2	K1467	Flat Washer M6 x 12mm OD	1
3	J0801	1/4\"-28 Zirc Fitting	1

A2067 02 Idler Mount Assembly Exploded Parts View

Item #	Part #	Desc.	Qty.
1	B0958_02	Idler Mnt Pl	1
2	K2038	Ny-Flange Lock Nut 3/8\"-16	2
3	K1463	Flat Washer .720 ID x 1.500 OD x .250 T	2
4	K1219	Jam Nut 3/8\"-16	1
5	K1192	HHCS 3/8\"-16 x 1-1/4\" GR5	1
6	K0329	Nylock Nut 7/16\"-14 GR8	1
7	M0003	Idler Pulley	1
8	K1462	HHCS 3/8\"-16 x 1-3/4\" GR8	1
9	K1464	Shoulder Bolt 7/16\"-14 / Idler	1
10	J0024	Torsion Spring	1
11	A2092	Idler Arm Assy	1
12	B0974	Idler Base Plate	1

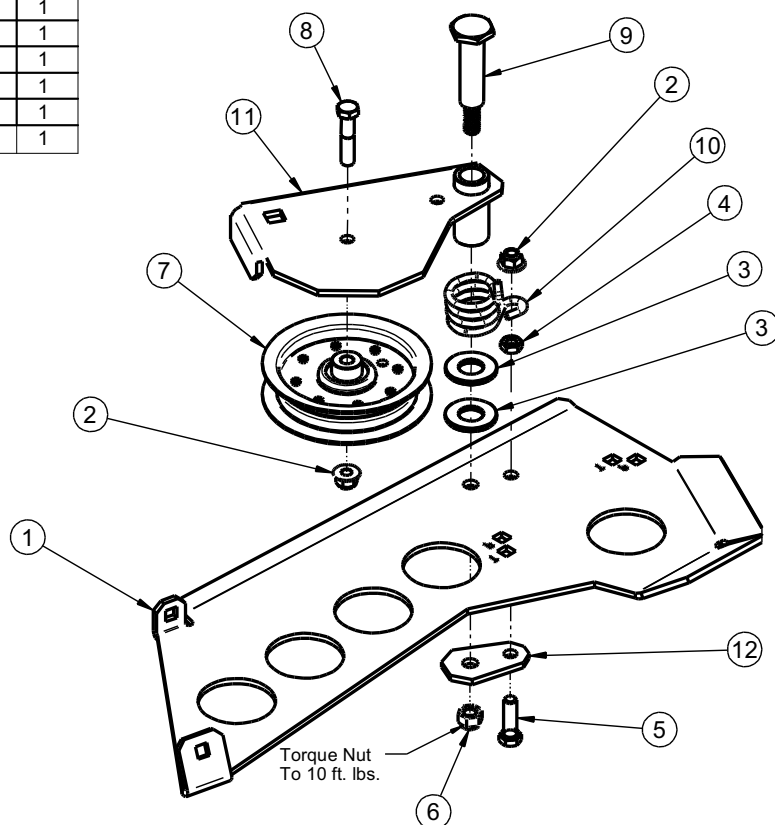

A2058 01 Gearbox Sub-Assembly Exploded Parts View

Item #	Part #	Desc.	Qty.
1	A2048	Clutch Flange	1
2	M0002	Gearbox	1
3	N0005	7/8" Pillow Block Bearing / Fenner	1
4	J0272	Woodruff Key #9	1
5	K0035	Set Screw 5/16"-18 x 1/4" Cup Point	1
6	K0428	HHCS 5/16"-24 x 1" GR8	1
7	K0043	Lock Washer 5/16"	1

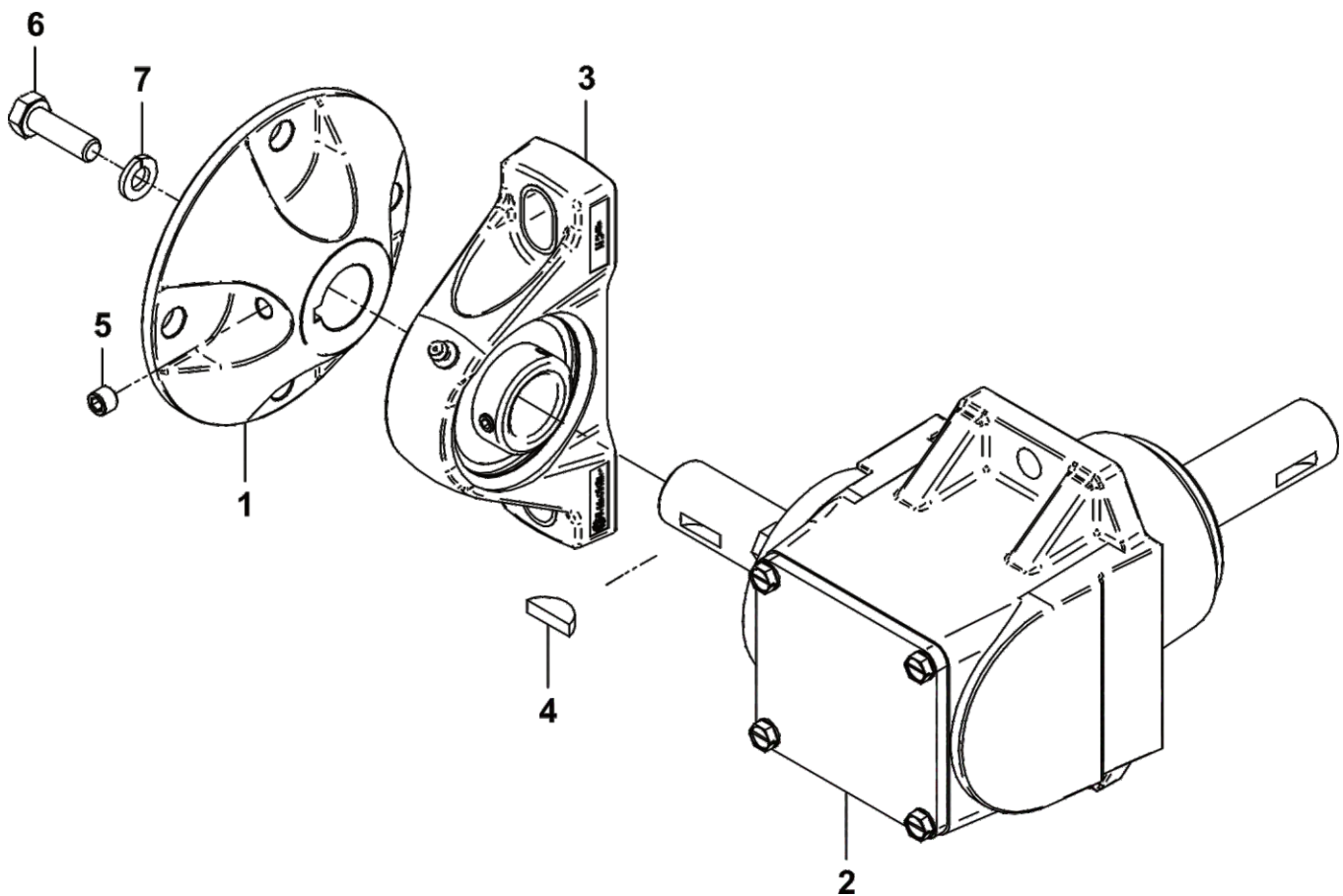

A2059 02 Clutch Sub-Assembly Exploded Parts View

Item #	Part #	Desc.	Qty.
1	M0001_01	Electric Clutch	1
2	S0007	Clutch Shaft (Rev 1)	1
3	N0004	Flange Bearing / 1" ID / 2-Bolt	1
4	B2217	Clutch Lower Bearing Mnt.	1
5	S0239	Eng. Pulley Bushing #41	1
6	K0076	Key 1/4" x 3/4" Long	1
7	M0309	A-Section Pulley / 4.75 OD (PTO-X)	1
8	K1510	HHCS 3/8"-16 x 1-1/8" GR5 Zinc	2
9	K1121	3/8"-16 Nyloc Nut GR5	2
10	K0359	HHCS / 7/16"-20 x 4" w/ Patch	1
11	K0140	Lock Washer 7/16" / High-Collar Helical Spring	1
12	K0278	Double Indented Washer 7/16" / 1.375 OD x .440 ID x .179 T	1

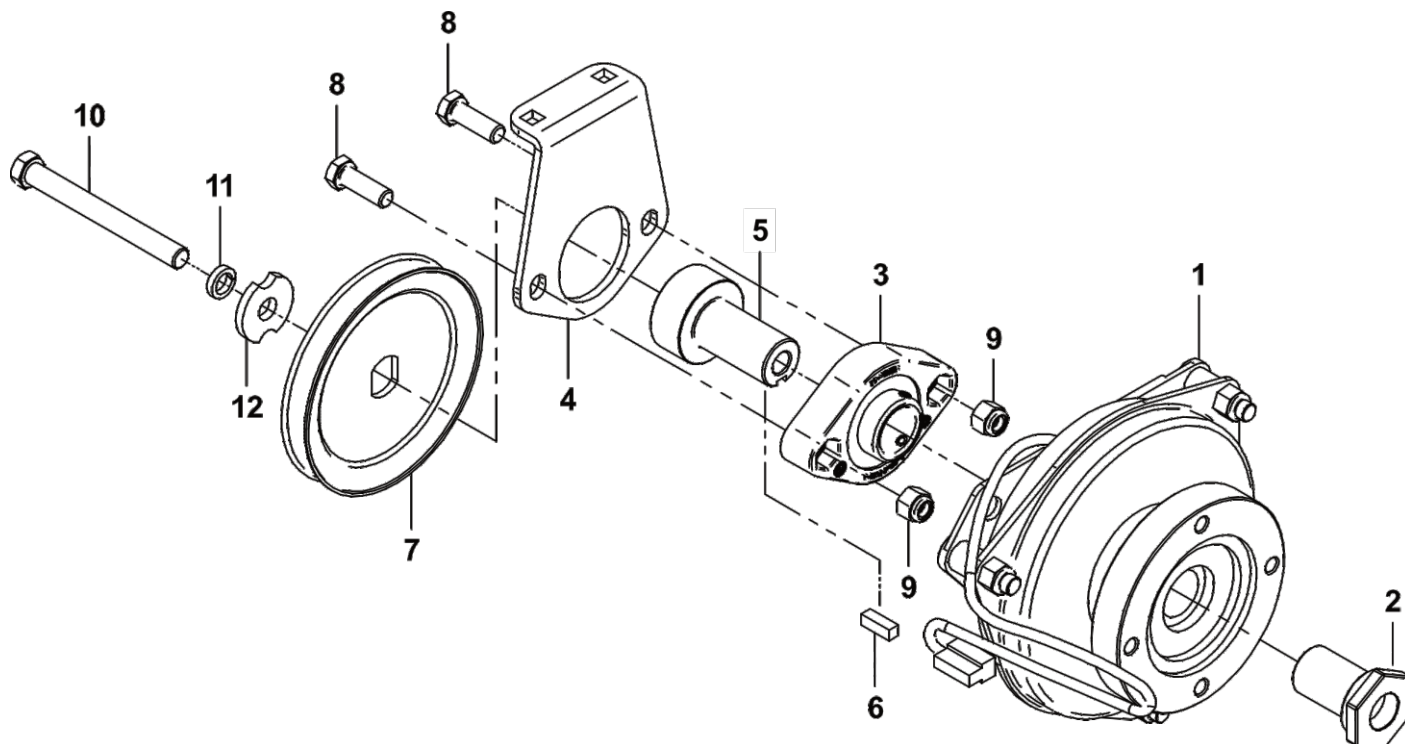

A2057 02 Drive Assembly Exploded Parts View

Item #	Part #	Desc.	Qty.
1	A2058_01	Gearbox Sub-Assy	1
2	A2059_02	Clutch Sub-Assy	1
3	K0343	HHCS 3/8"-16 x 7/8" GR8	4
4	K0048	Lock Washer 3/8"	4

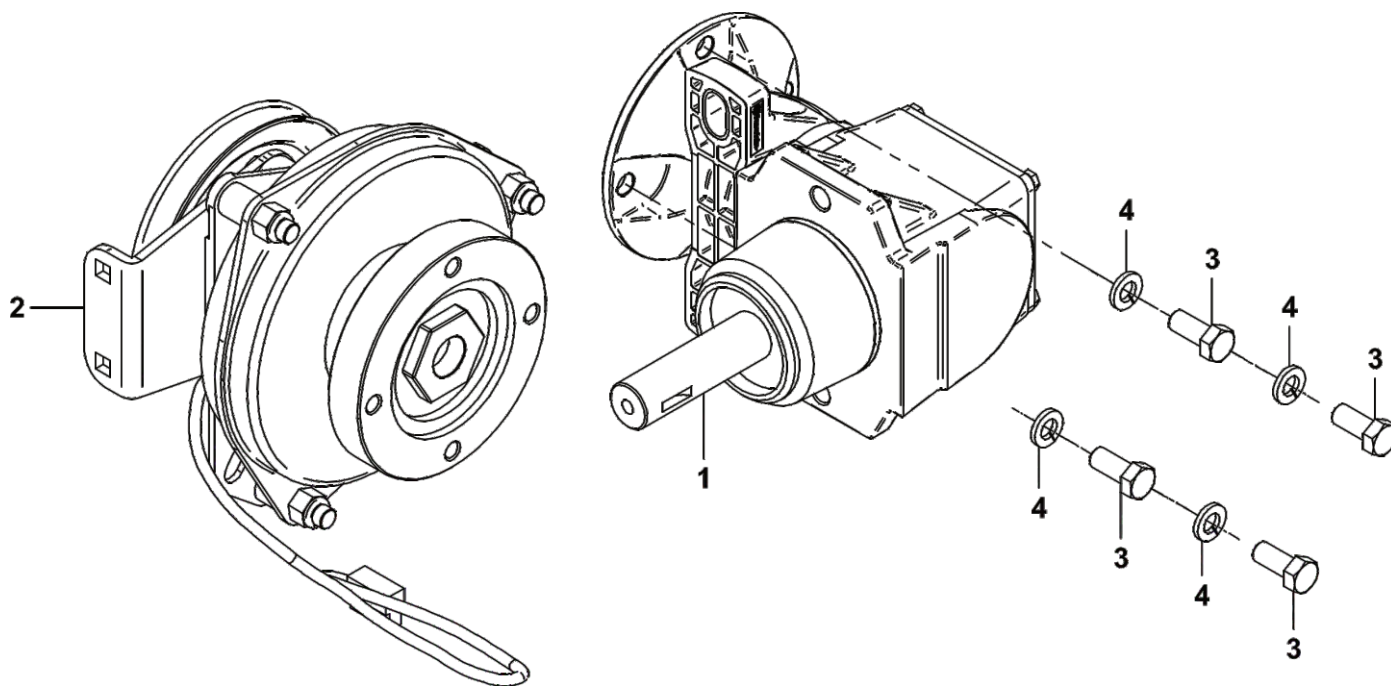

A2060 02 Mounted Drive Assembly
Exploded Parts View

Item #	Part #	Desc.	Qty.
1	A2034	Drive Mnt Assy	1
2	A2057_02	Drive Assy	1
3	B0940	Spacer Plate	1
4	K1511	SHCS 1/2"-13 x 2" A574 Zinc	2
5	K0057	Lock Washer I/T 1/2" / Zinc	2
6	K1512	SHCS 3/8"-16 x 1" A574 Zinc	2
7	K0048	Lock Washer 3/8"	2

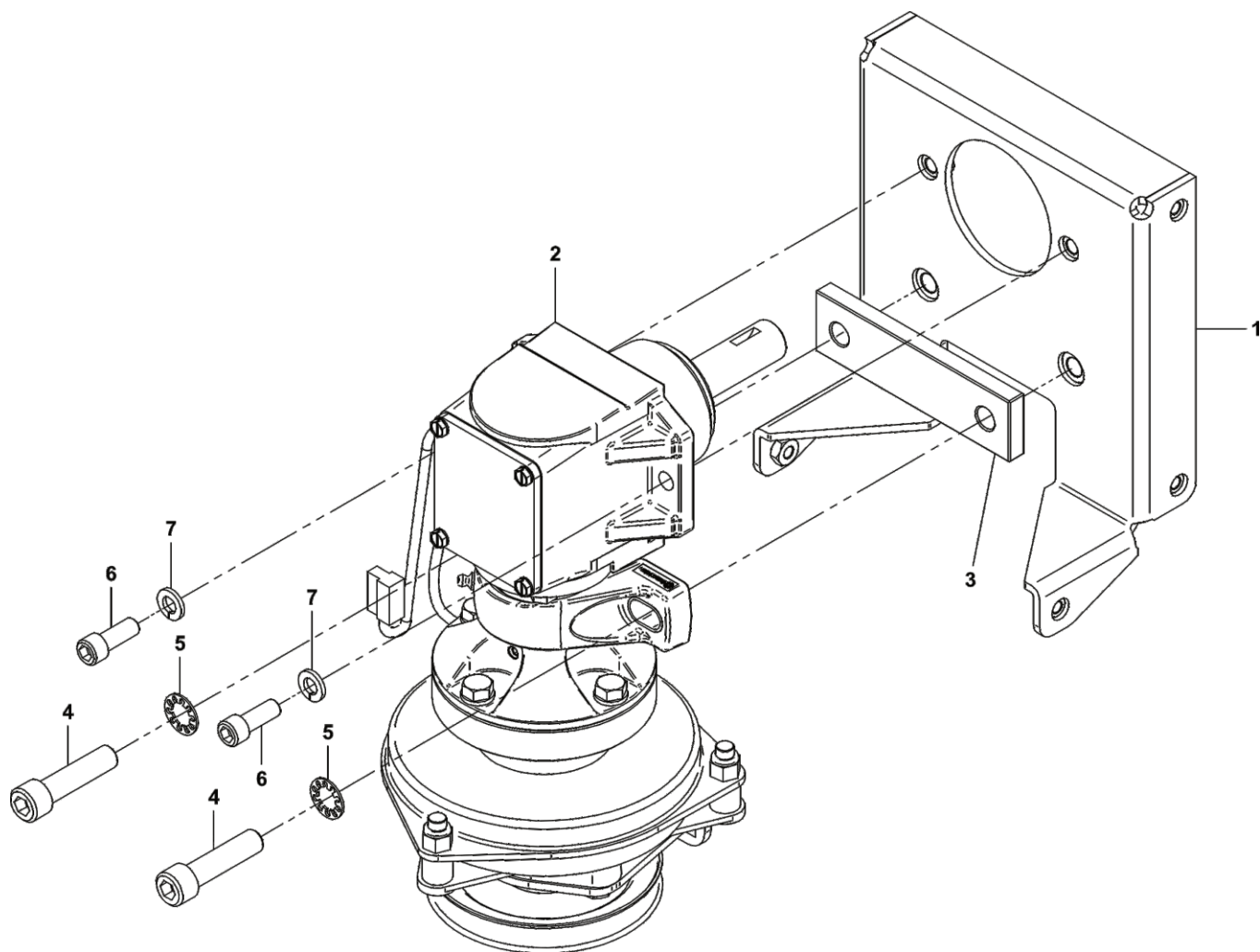

A2039 03 Base Drive Assembly

Exploded Parts View

Item #	Part #	Desc.	Qty.
1	A2060_02	Mounted Drive Assy	1
2	A2035_02	Housing Mnt Assy	1
3	B1100_01	Idler Assy Mount Plate	1
4	B0942_02	Anti-Rotation Brkt	1
5	A2032	Drive Arm Assy	1
6	B0938_01	Drive Guard	1
7	K1153	HHCS 5/16"-18 x 3/4"	4
8	K1154	HHCS 5/16"-18 x 1"	4
9	K0043	Lock Washer 5/16"	8
10	K1142	5/16"-18 x 3/4" Carriage Bolt	6
11	K2516	Ny-Flange Lock Nut 5/16"-18	6
12	K0343	HHCS 3/8"-16 x 7/8" GR8	1
13	K1477	Flat Washer / 3/8" / .406 ID x .812 OD x .125 Thk	1
14	K1476	Reverse Lock Nut / 3/8"-16 Grade C	1
15	P0271	Quick Connect Wire Harness	1
16	K0353	HWHTCS 1/4"-20 x 1/2"	2

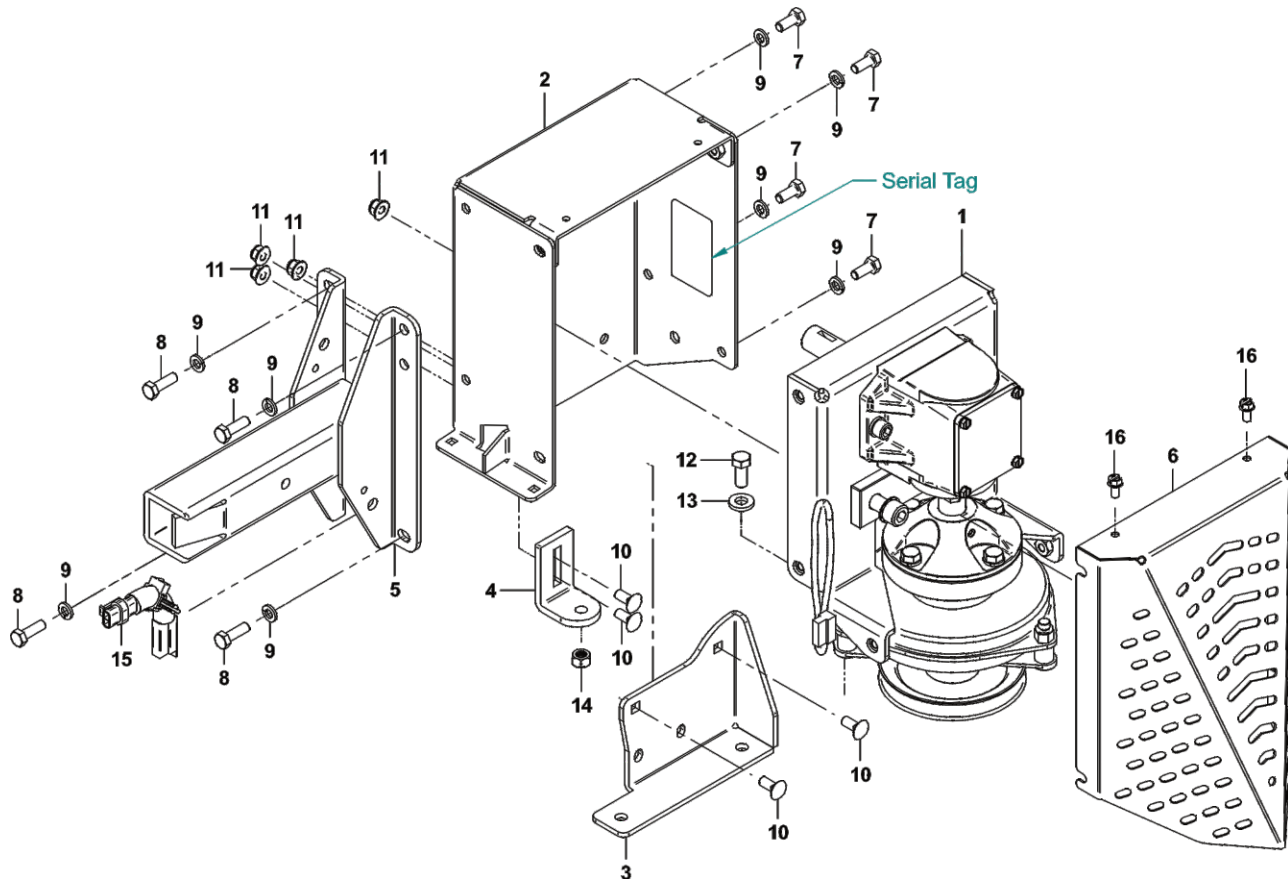

A2061 03 Drive Assembly / 4 Blade Impeller

Exploded Parts View

Item #	Part #	Desc.	Qty.
1	A2039 03	Drive Assy / Base 1.5	1
2	A0645	4-Blade Impeller Weldment	1
3	E4052B	Blower Hsg Back	1
4	E4052F	Blower Hsg Front	1
5	K1154	HHCS 5/16"-18 x 1"	4
6	K0044	I/T Tooth Lock Washer 5/16"	4
7	S0157	Taperlock Bushing 7/8"	1
8	K1225	HHCS 1/4"-20 X 1" GR8	2
9	S0159	Spacer Bushing .938 OD x .325 ID x .345 T	1
10	K0042	Flat Washer 5/16" / .875 OD x .380 ID x .075 T	2
11	K0284	Double Indented Washer 3/8" / 1.375 OD x .380 ID x .179 T	1
12	K1465	HHCS 5/16"-24 x 1-1/2" GR8	1
13	K1401	1/4"-20 x 1" SHCS / Zinc / GR8	7
14	K1126	Flange Nut 1/4"-20	7

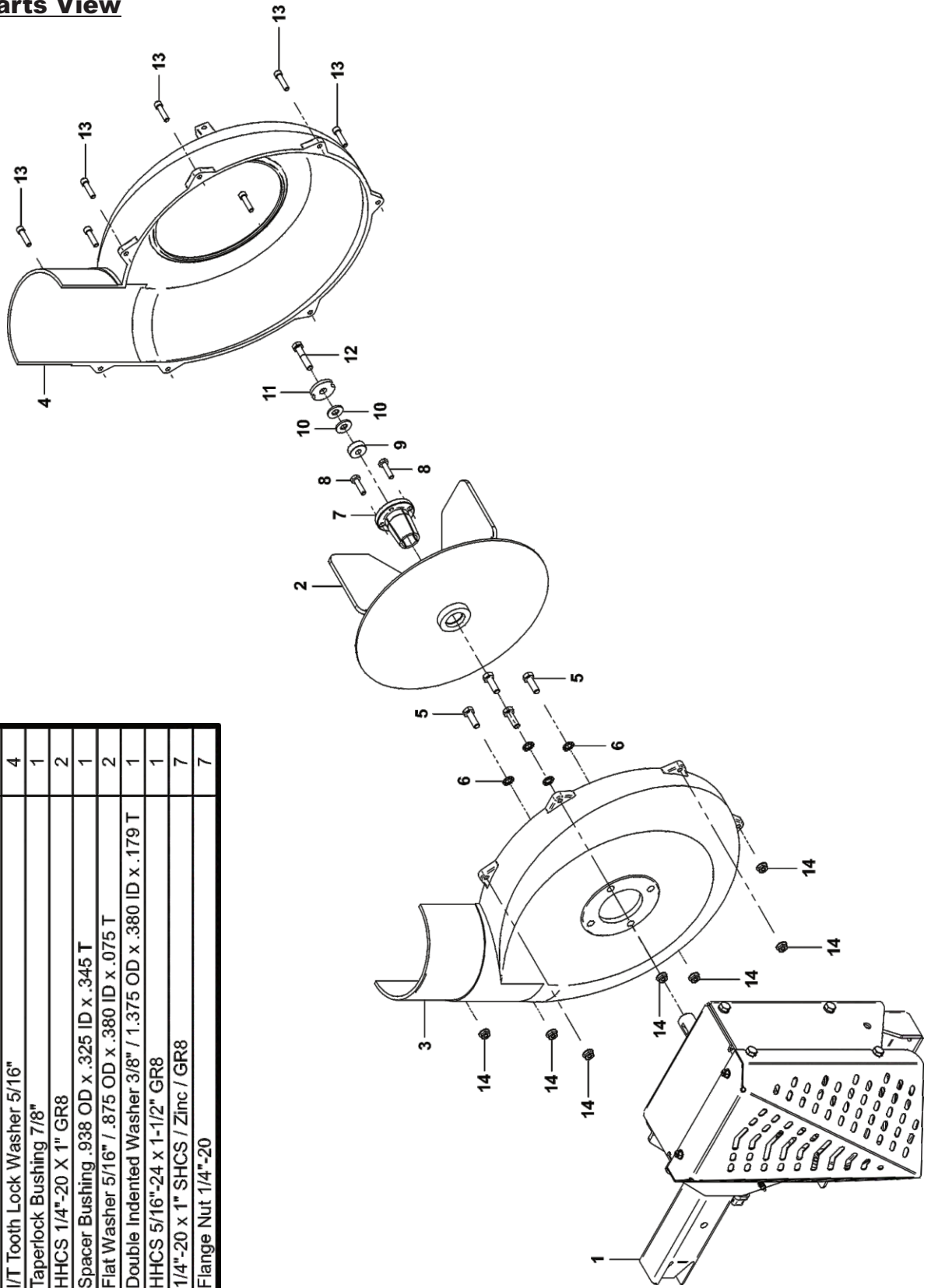

A2100 6512 Box Assembly / Standard
Exploded Parts View

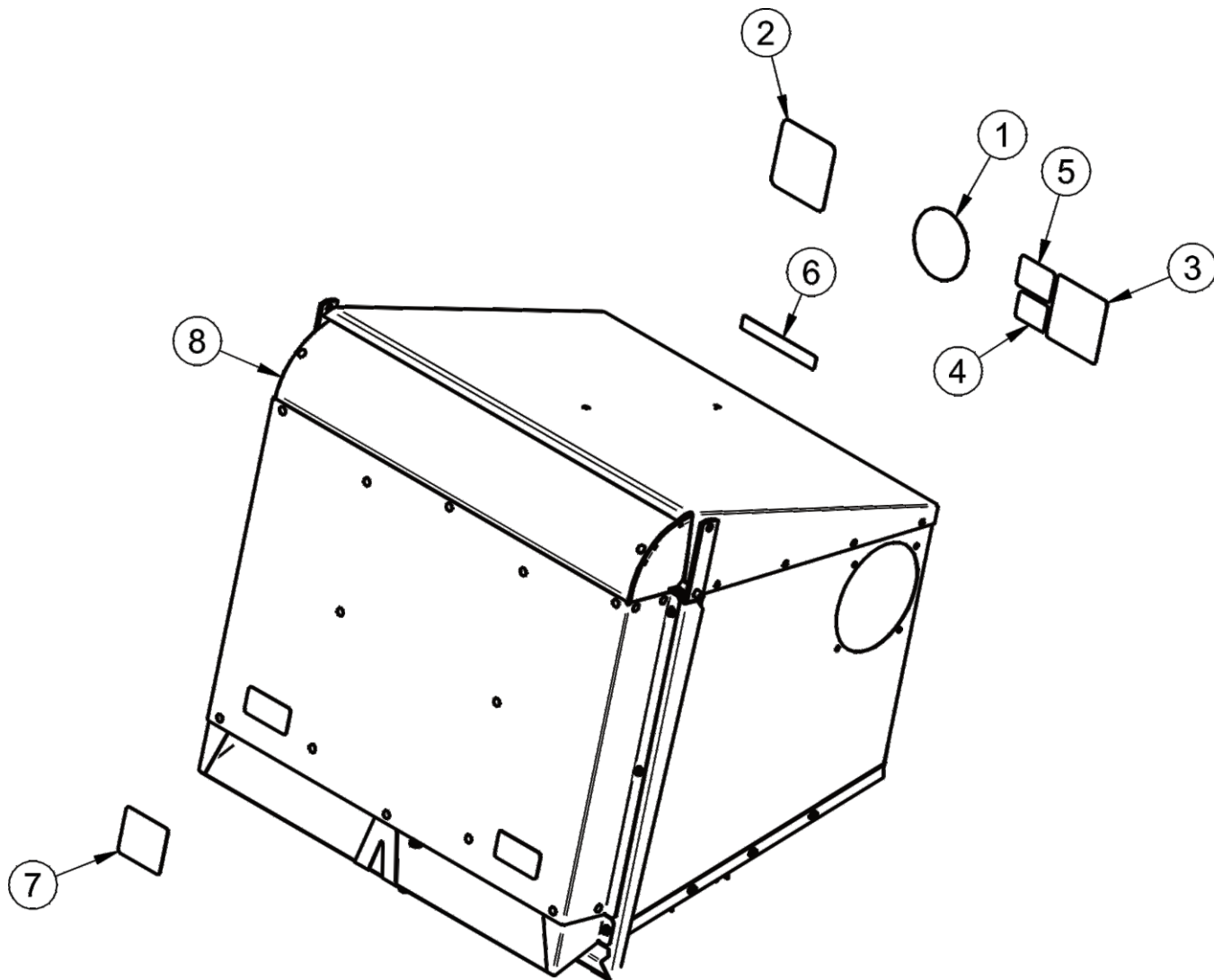

Item #	Part #	Desc.	Qty.
1	R0022	Decal / Built In The USA / Lg	1
2	R0026	Decal / Operation	1
3	R1069	Decal / Warning - Turn Off Blower	1
4	R1051	Decal / Warning - Use Hearing Protection	1
5	R1054	Decal / Important Check Hoses	1
6	R1055	Decal / To Dump Grass	1
7	R1053	Decal / Caution	1
8	A2226	6512 Box Assy. / Base Model	1

A2226 6512 Box Assembly / Base Model

Exploded Parts View

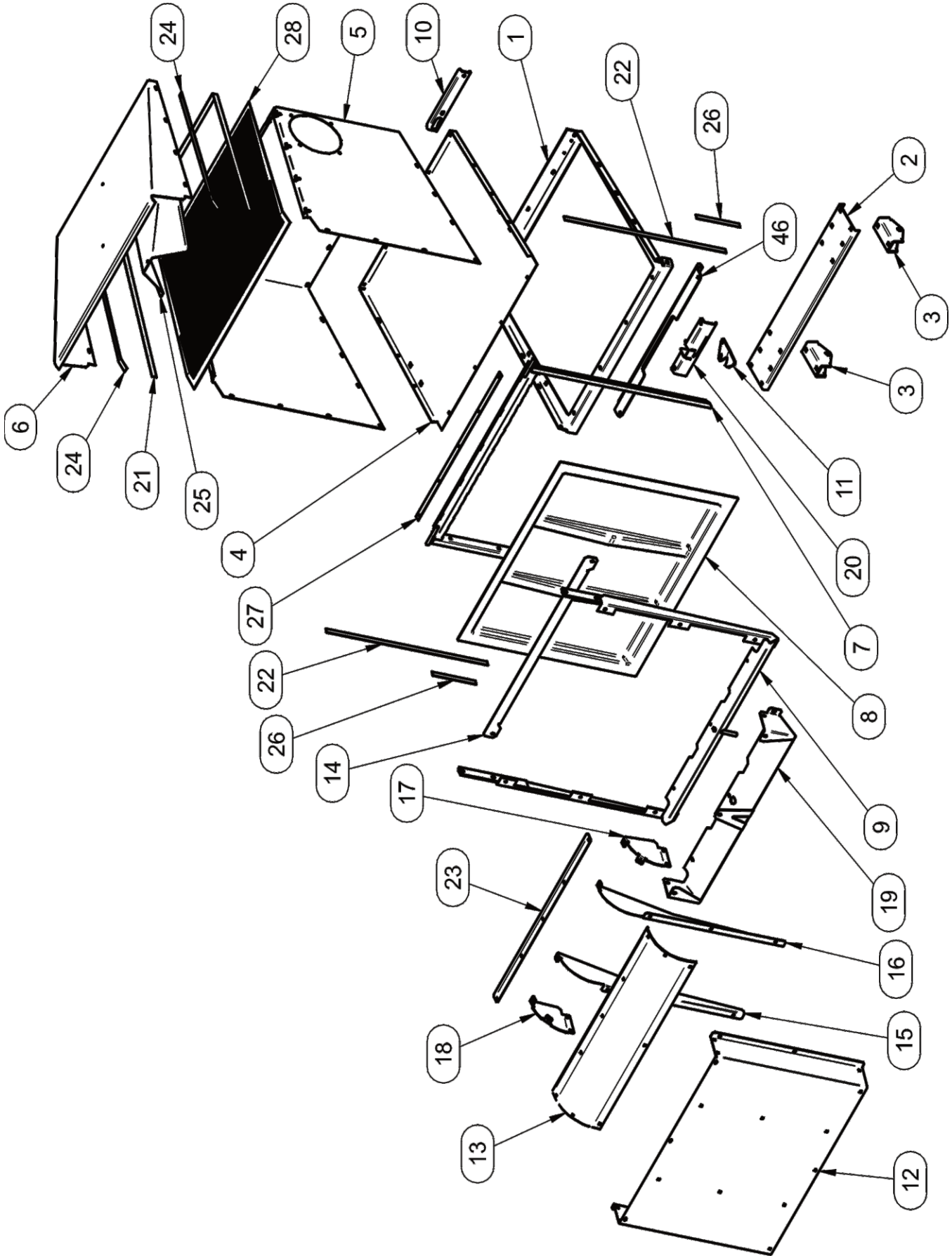

A2226 6512 Box Assembly / Base Model**Exploded Parts List**

Item #	Part #	Desc.	Qty.
1	B1750	Base Frame	1
2	B1727	Base Frame Pivot Mount	1
3	B1574	Pivot Bracket	2
4	C0024	Box Bottom	1
5	C0080	Box Back & Sides	1
6	C0081	Box Top	1
7	A0938	Frame Weldment / Box Opening	1
8	V1131	12 Box Door	1
9	A0738	Frame Weldment / Door Stiffener	1
10	B1730	Latch Handle Mount Bracket	1
11	B0996	Latch Hook	1
12	C0075	Dust Diverter	1
13	V0051	Dust Flap	1
14	B3688	Upper Door Member	1
15	C0076	Left Dust Diverter Brace	1
16	C0077	Right Dust Diverter Brace	1
17	C0079	Right Outer Dust Flap Brace	1
18	C0078	Left Outer Dust Flap Brace	1
19	B0991	Dust Diverter Guard Bracket	1
20	A2104	Latch Mount Plate Assy.	1
21	V0052A	Dust Seal / Top Sides	1
22	V0052B	Dust Seal / Long Door Sides	2
23	B1006	Dust Flap Stiffener	1
24	B1007	Screen Clamp Strip / Side	2
25	C0087	Screen Support	1
26	V0052C	Dust Seal / Short Door Sides	2
27	B1008	Screen Clamp Strip / Rear Door	1
28	B8113	Screen / Steel Wire Mesh	1
46	B2021	Box Stop / 6512	1

A2107 Latch Rod Assembly
Exploded Parts View

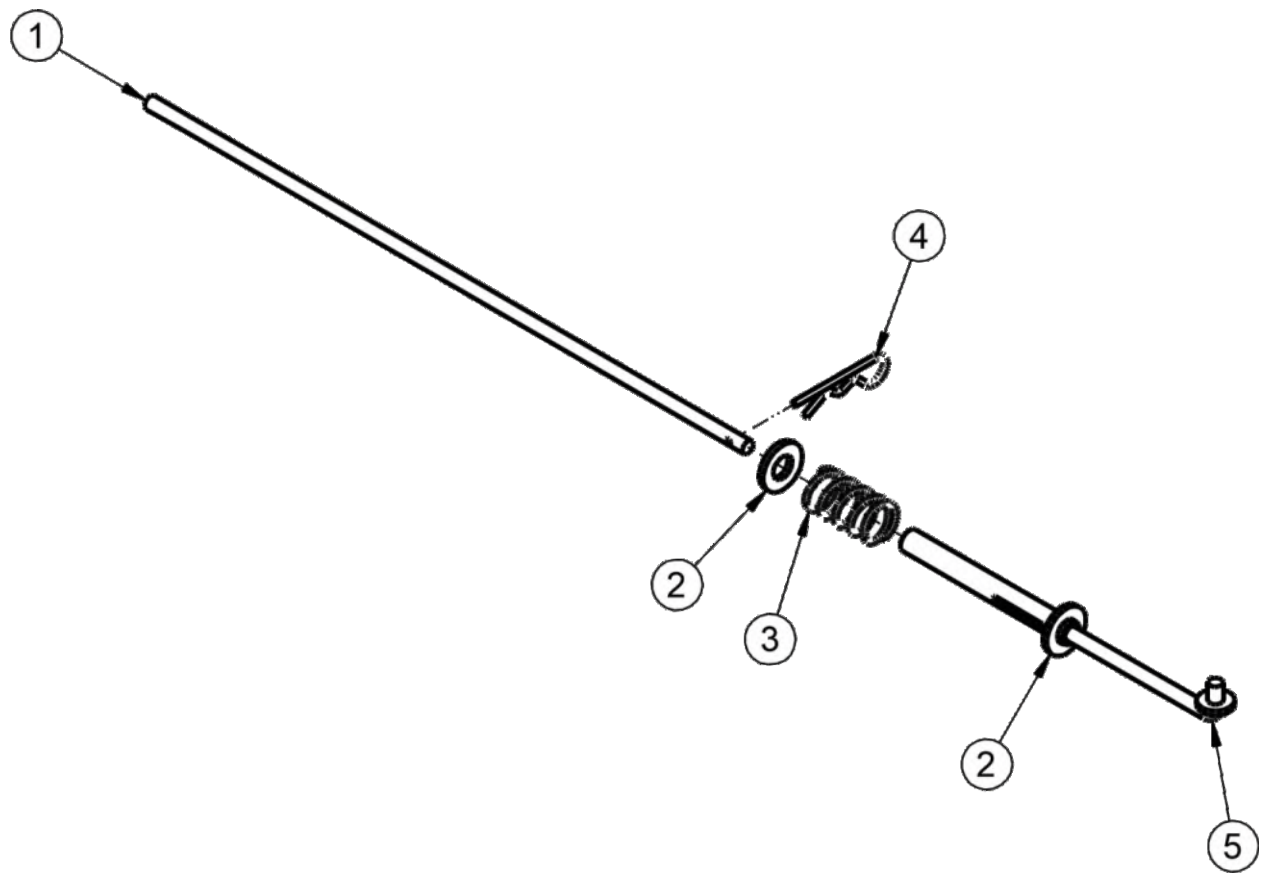

Item #	Part #	Desc.	Qty.
1	B1000	Latch Rod / Hook Side	1
2	K0400	1/2" Flat Washer 1.084 OD x .528 ID x .120 T	1
3	J0303	Spring	1
4	K0086	Hair Pin Clip .125 OD x 2.50	1
5	A2106	Latch Rod Weldment	1



Unit Model #: 38651201

Mower: Dixie Chopper Eagle / Jacobsen Z1900

Mower Type: 2754KW, 2754KOE, 2760KW & 2760KOE

Deck Size: 54" & 60"

Deck Type:

Revision #: 2 - PTO-X 1.5 - 7/23/24 - BS

Owner's Manual: Q0541

Vac Type: 12 Cubic Foot Pro 12 DFS

Drive Type: PTO-X Drive

Fits Year(s): 2018 - Newer

A2218 Vac Kit

- (1) C0088 Debris Deflector
- (1) C0074 Inlet Ring (Split Cut)
- (1) V0025 6" & 7" Plastic Inlet
- (1) A2100 12 Cu. Ft. Box Assy
- (1) F0060-31 6" x 31" Upper Hose
- (1) A0897 Box Handle Assy.
- (1) A1192 Main Frame Assy
- (1) A0897 Box Handle Assy.
- (1) B1096 Left Main Frame Mount
- (1) B1095 Right Main Frame Mount
- (1) A2107 Latch Rod Assy.
- (2) B2526 Door Linkage
- (1) HB0777 Vac Kit HW Bag
- (2) J0060 6" Hose Clamp

A2217 Mount Kit

- (1) B1083 Upper PTO Mnt. Plate
- (1) B1090 Left Mnt. Plate
- (1) B1084 Rear Mnt. Plate
- (1) B1082 Lower PTO Mnt. Plate
- (1) A2207 Mount Arm / Tube Assy.
- (1) A2069_02 Belt Guard Assy.
- (1) A2067_02 Idler Mount Assy.
- (1) E6009 8" Blower Cone
- (2) J0080 8" Hose Clamps
- (1) A2061_03 Drive Assy. w/ 4-Blade Impeller
- (1) HB0776 Mount Kit HW Bag
- (1) M0320 AK73 Kevlar Belt
- (1) B1081 Right Mnt. Plate
- (1) B1084 Rear Mnt. Plate
- (1) B1082 Lower PTO Mnt. Plate
- (1) B1081 Right Mnt. Plate
- (1) HB0778 Engine Pulley HW Bag
- (1) F0080-38 8" x 38" Lower Hose
- (1) HB0702 Wiring Harness Kit
- (1) PECO

A2261 Weight Kit

- (1) B1098 Caster Weight Bracket
- (6) Y0025 28 lbs Weight
- (1) B0989 Weight Bracket
- (1) B1099 Caster Weight Bracket Brace
- (1) HB0791 Weight Kit HW Bag

A2130 Boot Kit

- (1) HB0694 Boot Kit HW Bag
- (1) B0988 Boot Plate Assy
- (1) E0033A 8" Boot W/ Decal
- (1) B0990 Boot Adapter

SAFETY DECALS

To promote safe operation, New PECO, Inc. supplies safety decals on all products manufactured. Damage can occur to safety decals either through shipment, use or reconditioning. Contact your local Service Center for replacement decals.



Part# R1070
PECO Logo



Part# R0022
Designed & Built
In The USA



Part #: R2007
Danger - Never Use Hands



Part #: R2008
Danger - Rotating Blades



Part #: R1054
Important - Hose Wear

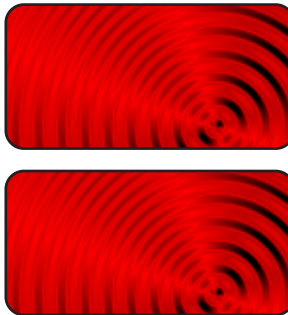

Part #: R1057 - (2)
Red Reflectors



Part #: R1069
Warning - Turn Off Blower



Part # R0024
Danger - Keep Hands
Clear



Part #: R1051
Warning - Hearing Protection



Part # R0025
Danger - Rotating
Blades

SECTION III OPERATING INSTRUCTIONS

General Safety

Only qualified people familiar with this operator's manual and the mower's operator's manual should operate this machine.

Operation And Tips On Mowing

- A. Perform BEFORE EACH USE the maintenance list referenced in Section IV.
- B. Start mower.
- C. With the mower at high idle speed, engage the mower deck.
- D. While seated in the operator's seat, move Bagger PTO switch to the on position. With the PTO assembly engaged, you can proceed to operate the control levers of the mower.

NOTE: If the collection system does not appear to be collecting the grass clippings, disengage the deck and PTO assembly, then, engage the parking brake and turn the mower off. Check upper and lower hoses for any clogs.

To obtain the maximum effectiveness from your collection system, the tips listed below should be followed:

- * Watch your speed- Normal conditions will allow a speed of up to approximately 4 mph, but thick, heavy damp conditions will require reduced ground speed.
- * Mow with sharp blades- A sharp blade cuts cleaner.
- * Wet grass and leaves will decrease effectiveness and will increase horsepower requirements.
- * Mow at higher cutting heights- Remove and mulch no more than 2" of grass length with each mowing. (Experts recommend not cutting off more than 1/3 of the grass blade length at any given time.)
- * Mow twice, at different height settings, (high, then low), if grass is extra tall.
- * Remember that horsepower requirements will vary with the mowing conditions such as type and height of turf grass, moisture content, amount of leaves, whether the terrain is flat or hilly, etc.

Disengagement Of The PTO Assembly

- A. To disengage the PTO assembly, move Bagger PTO switch to the off position.

WARNING: The PTO assembly blades will continue to spin. DO NOT TOUCH the PTO assembly, pulleys, or the belt until the tractor is turned off. DO NOT adjust the belt tension until the mower is turned off. Refer to the Belt Installation section of the manual.

Unloading The Collection System

NOTE: To determine when the collection bags are full, follow the following steps:

- A. Stop the forward movement of the mower.
- B. Disengage the mower deck.
- C. Disengage the PTO assembly.
- D. Engage the parking brake.
- E. Once the parking brake has been engaged, then and only then, walk behind the mower and check the collection bags by first unhooking the rubber strap with S-hook that secures the plastic top, then lift the plastic hood. Load in bags should not exceed the height of the installed bag.
- F. To remove the bags from the frame, slide bags out and turn bags over to deposit clippings.
- G. Slide empty bags back onto the frame and secure plastic top with the rubber strap with S-hook.

NOTE: Do not allow collection bags to become over-filled as potential damage may occur to your equipment. Also, be sure to clean the hood screen as needed.

SECTION IV MAINTENANCE

Maintenance Checklist

Before each use:

1. Check blades and spindles to be sure that no foreign objects, such as wire or steel strapping bands, are wrapped around them.
2. Inspect blades for wear. Replace if necessary. If it is necessary to sharpen the blades, remove the blades from the spindles before sharpening. DO NOT sharpen blades while still attached to the mower.

3. Make sure all shields are in place and in good condition. Repair or replace any missing or damaged shields.
4. Perform lubrication per instructions.
5. Listen for abnormal sounds, which might indicate loose parts, damaged bearings, or other damage. Correct any deficiency before continuing operation.
6. With the engine off, engage the blower assembly. Check the belt tension and inspect the pulley belt for cracks or tears.
7. Check for wear or deterioration of the upper or lower hoses. If there are any portions of the hose that have been torn or worn through, replace immediately.

After Each Use:

1. Clean all debris from machine especially from the container, underneath the belt shields, and safety decals. Replace any missing or illegible decals.
2. Inspect the unit for worn or damaged components. Repair or replace before the next use. Any replacement component installed during repair shall include the component's current safety decal specified by the manufacturers to be affixed to the component.
3. Under normal usage, the bag material is subject to deterioration and wear and should therefore be frequently checked for necessary replacement. Any replacement bag should be checked to ensure compliance with the original manufacturer's recommendations or specifications.
4. Check belt for proper tension.

4-2 Lubrication

Gearbox:

NOTE: The gearbox is filled with 6.0 oz. of Mobilube HD Plus 80W-90 oil and permanently sealed. There is no need for scheduled lubrication. The oil level should only be checked if a leak is observed or if a change in gearbox noise is noticed.

Operators are recommended to check for leaks weekly. If a leak is observed, both the gasket and the seals are recommended to be replaced.

Replace the oil using 5.5 oz. of the recommended Mobilube HD Plus 80W-90 oil. Be sure to not overfill.

Blower Assembly:

NOTE: The following is for older PTO models that contain a greaseable zirc fitting. Newer models contain maintenance-free bearings and are without a greasable fitting.

1. On initial use: Grease the fitting on the blower shaft.
2. Every 25 hours of use: Re-grease the grease fitting.

NOTE: Use only white lithium based grease for lubrication of the shaft on the blower assembly.

SECTION V - PARTS & SERVICE

5-1 Parts And Service Information

Collection system owners should record the name and telephone number of their Service Center. Your Service Center will be happy to supply replacement parts, accessories, and do any service or repairs to your collection system. If for any reason your Service Center is unable to service your collection system or supply replacement parts, contact New PECO, Inc. and include the following information on the chart below.

DOCUMENT THE FOLLOWING INFORMATION FOR FUTURE REFERENCE

Unit Model Number: _____

Unit Engine Size: _____

Unit Serial Number: _____

Date of purchase: ____ / ____ / ____

Dealer/Distributor Name: _____

Address: _____ **State:** _____ **Zip:** _____

Phone Number: _____

New PECO, Inc.

10 Walden Dr | Arden, North Carolina 28704

Phone: 1-800-438-5823 | 828-684-1234

Fax: 828-684-0858

Email: peco@lawnvac.com

Website: www.lawnvac.com

TORQUE SPECIFICATIONS

Proper torque for American fasteners used on Peco equipment.
Recommended Torque in Foot Pounds (Newton Meters).*

AMERICAN Bolt Head Markings

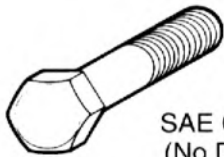

SAE Grade 2
(No Dashes)

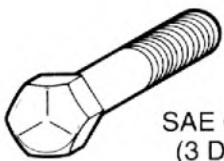

SAE Grade 5
(3 Dashes)

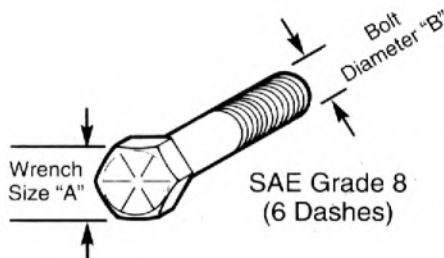

SAE Grade 8
(6 Dashes)

WRENCH SIZE (IN.) "A"	BOLT DIAMETER (IN.) "B" AND THREAD SIZE	SAE GRADE 2	SAE GRADE 5	SAE GRADE 8
7/16	1/4 - 20 UNC	6 (7)	8 (11)	12 (16)
7/16	1/4 - 28 UNF	6 (8)	10 (13)	14 (18)
1/2	5/16 - 18 UNC	11 (15)	17 (23)	25 (33)
1/2	5/16 - 24 UNF	13 (17)	19 (26)	27 (37)
9/16	3/8 - 16 UNC	20 (27)	31 (42)	44 (60)
9/16	3/8 - 24 UNF	23 (31)	35 (47)	49 (66)
5/8	7/16 - 14 UNC	32 (43)	49 (66)	70 (95)
5/8	7/16 - 20 UNF	36 (49)	55 (75)	78 (106)
3/4	1/2 - 13 UNC	49 (66)	76 (103)	106 (144)
3/4	1/2 - 20 UNF	55 (75)	85 (115)	120 (163)
7/8	9/16 - 12 UNC	70 (95)	109 (148)	153 (207)
7/8	9/16 - 18 UNF	79 (107)	122 (165)	172 (233)
15/16	5/8 - 11 UNC	97 (131)	150 (203)	212 (287)
15/16	5/8 - 18 UNF	110 (149)	170 (230)	240 (325)
1-1/8	3/4 - 10 UNC	144 (195)	266 (360)	376 (509)
1-1/8	3/4 - 16 UNF	192 (260)	297 (402)	420 (569)
1-5/16	7/8 - 9 UNC	166 (225)	430 (583)	606 (821)
1-5/16	7/8 - 14 UNF	184 (249)	474 (642)	668 (905)
1-1/2	1 - 8 UNC	250 (339)	644 (873)	909 (1232)
1-1/2	1 - 12 UNF	274 (371)	705 (955)	995 (1348)
1-1/2	1 - 14 UNF	280 (379)	721 (977)	1019 (1381)
1-11/16	1-1/8 - 7 UNC	354 (480)	795 (1077)	1288(1745)
1-11/16	1-1/8 - 12 UNF	397 (538)	890 (1206)	1444 (1957)
1-7/8	1-1/4 - 7 UNC	500 (678)	1120 (1518)	1817 (2462)
1-7/8	1-1/4 - 12 UNF	553 (749)	1241 (1682)	2013 (2728)
2-1/16	1-3/8 - 6 UNC	655 (887)	1470 (1992)	2382 (3228)
2-1/16	1-3/8 - 12 UNF	746 (1011)	1672 (2266)	2712 (3675)
2-1/4	1-1/2 - 6 UNC	870 (1179)	1950 (2642)	3161 (4283)
2-1/4	1-1/2 - 12 UNF	979 (1327)	2194 (2973)	3557 (4820)

METRIC

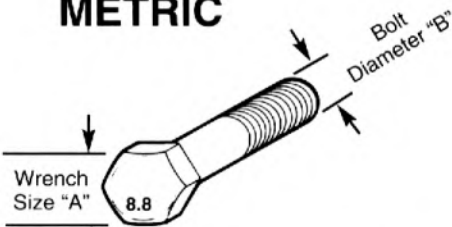

Numbers appearing on bolt heads indicate ASTM class.

Proper torque for metric fasteners used on Peco equipment.
Recommended torque in foot pounds (newton Meters).*

WRENCH SIZE (mm) "A"	BOLT DIA. (mm) "B"	ASTM 4.6	ASTM 8.8	ASTM 9.8	ASTM 10.9
8	5	1.8 (2.4)		5.1 (6.9)	6.5 (8.8)
10	6	3 (4)		8.7 (12)	11.1 (15)
13	8	7.3 (10)		21.1 (29)	27 (37)
16	10	14.5 (20)		42 (57)	53 (72)
18	12	25 (34)	74 (100)	73 (99)	93 (126)
21	14	40 (54)	118 (160)	116 (157)	148 (201)
24	16	62 (84)	167 (226)	181 (245)	230 (312)
30	20	122 (165)	325 (440)		449 (608)
33	22		443 (600)		611 (828)
36	24	211 (286)	563 (763)		778 (1054)
41	27		821 (1112)		1138 (1542)
46	30	418 (566)	1119 (1516)		1547 (2096)

*Use 75% of the specified torque value for plated fasteners. Use 85% of the specified torque values for lubricated fasteners.

Troubleshooting

2017 (v1.0)

Collection System Performance

Problem	Possible Cause	Corrective Action
Abnormal Vibration	<ul style="list-style-type: none"> • Cutting blades are bent or unbalanced • Loose blower pulley or pulley assembly • Impeller blade out of balance 	<ul style="list-style-type: none"> • Install new cutting blade • Tighten the pulley • Contact dealer to replace
Reduced collection system performance	<ul style="list-style-type: none"> • Low engine speed • Plugged screen • Loose belt • Full collection bags 	<ul style="list-style-type: none"> • Always operate collection system at full throttle • Remove debris, leaves, or grass clippings from the screen • Replace/tighten belt • Empty the collection bags
Blower and hoses plugging too frequently	<ul style="list-style-type: none"> • Collection bags are too full • Low engine speed • Grass is too wet • Grass is too long • Ground speed is too fast • Worn belt • Loose belt 	<ul style="list-style-type: none"> • Dump more frequently • Always operate collection system at full throttle • Cut grass when it is dry • Cut the grass several times • Drive slower at full throttle • Replace belt • Adjust the pulley and tighten belts
Debris blowout	<ul style="list-style-type: none"> • Collection bags are too full • Plug/clog in the collection system • Ground speed is too fast 	<ul style="list-style-type: none"> • Dump more frequently • Clean the collection system • Drive more slowly at full throttle
Impeller doesn't rotate freely	<ul style="list-style-type: none"> • Plug in the blower housing • Worn impeller blade • Shaft bearings bad/failing 	<ul style="list-style-type: none"> • Clean the blower housing • Contact dealer to replace • Contact dealer to replace

Notes



New PECO, Inc.
10 Walden Dr | Arden, North Carolina 28704
Phone: 1-800-438-5823 | 828-684-1234
Fax: 828-684-0858
Email: peco@lawnvac.com
Website: www.lawnvac.com