



# PTO-X / ENGINE DRIVEN - GRASS COLLECTION SYSTEM

MODEL YEAR: 2020-Newer



## Z-Master 4000 Series 60" DECK

22651201 PTO-X

22651202 Briggs & Stratton 6.5HP V



# OPERATOR'S MANUAL

ASSEMBLY • OPERATION • MAINTENANCE

# GRASS COLLECTION SYSTEM

## TABLE OF CONTENTS

SECTION	PAGE	SECTION	PAGE
Safety	2	Hinge Kit Assy Installation	26
Safety Alert Symbols	3	Even Bag Fill Adjustment	26
Warranty	4	Bag Assy	27
I INTRODUCTION AND DESCRIPTION	5	Bag Assy Installation	27
Introduction	5	Length of Hose Adjustment	28
Description	5	Upper Hose Installation	28
II INSTALLATION FOR USE	6	Lower Hose To Blower Cone Installation	28
Preparation Of Mower	6	Lower Hose To Boot Installation	28
Rear Frame Bracket Installation	7	Wire Harness Installation	29-31
Lower Frame Bracket Installation	8	Throttle Kit Installation	32-33
Upper Frame Bracket Installation	9	Impeller Blade Removal/Replacement	34
Frame Gusset Installation	10	Weight Kit Installation	35-36
PTO Mount Arm Installation	11-12	Exploded Views & Parts List	37-48
Main Frame Leg Installation	13	Overall Parts List	49-50
Main Frame Assembly Installation	13	Safety Decals	51
PTO Drive Assy	14-15	III OPERATING INSTRUCTIONS	52
Drive Assembly and Belt Installation	16	General Safety	52
Belt Tension Adjustment	17-19	Operation & Tips On Mowing	52
Engine Mount Arm Assembly & Installation	20	Disengagement Of The PTO Assembly	52
Engine Drive Assembly Installation	21	Unloading The Collection System	52
Exhaust Diverter Installation	22	IV MAINTENANCE	53
Blower Cone Installation	23	Maintenance Checklist	53
Baffle Kit Installation	23	Lubrication	53
Boot Kit Installation	24	V PARTS AND SERVICE	53
Top Assy To Upper Frame Assy Installation	25	Parts And Service Information	53
Inlet Installation	25	Torque Specifications	54
		Troubleshooting	55

## SAFETY

1. Read the operator's manual carefully and familiarize yourself with the proper use of your attachment. Do not allow anyone who is not acquainted with the Safety Instructions to use your attachment.
2. Know the controls and how to stop them quickly. READ THE OPERATOR'S MANUAL!
3. Do not allow children to operate the machine. Do not allow adults to operate it without proper instruction.
4. Be especially watchful of children and pets entering into the area while operating.
5. Keep your eyes and mind on your machine while mowing or operating your attachment. Don't let others distract you.
6. Do not attempt to operate your machine when not in the driver's seat.
7. Always shut off blades and engine when emptying the container.
8. Stop machine, shut off deck attachment, set parking brake, shut off engine and remove ignition key before removing clogs, removing or replacing hose, boot, blower cone, or performing any maintenance.
9. Mow across the face of slopes (not more than 10 degrees); never up and down the face.
10. It is recommended that the container be emptied when half full while operating on slopes. Start mowing on slopes when the container is empty.
11. Inspect your lawn and remove any foreign objects before mowing. Never deliberately run the mower across any foreign object.
12. Wear hearing protection.
13. Wear eye protection to prevent debris from getting into your eyes.

# SAFETY

**WARNING!** NEVER operate the mower unless the discharge guard and either the deflector assembly or the vacuum collector adapter are fastened securely in place.

**WARNING!** Do not work around the mower deck boot or the blower area until you are certain that the mower blades and the blower impeller have stopped rotating.

**WARNING!** To avoid serious injury, perform maintenance on the vacuum collector; **ONLY AFTER STOPPING THE MOWER'S ENGINE AND WAITING FOR ALL MOVING PARTS TO COME TO A COMPLETE STOP.** Set the parking brake. Always remove the ignition key before beginning maintenance.

**WARNING!** For your own personal safety, **ALWAYS mow ACROSS the face of slopes and NEVER UP and DOWN the face. NEVER attempt to mow excessively steep slopes, and use caution when turning on any slope.**

## Safety Alert Symbol



This Safety Alert Symbol means: **“ATTENTION! BECOME ALERT! YOUR SAFETY IS INVOLVED!”**

This symbol is used to call attention to safety precautions that should be followed by the operator to avoid accidents. When you see this symbol, carefully read the message that follows and heed its advice. Failure to comply with safety precautions could result in death or serious bodily injury.

## Safety Signs

The signal words **DANGER**, **WARNING**, and **CAUTION** are used on the equipment safety signs. These words are intended to alert the viewer to the existence and the degree of hazard seriousness.



White letters on **RED**

This signal word indicates a potentially hazardous situation which, if not avoided, will result in death or serious injury.



Black letters on **ORANGE**

This signal word indicates a potentially hazardous situation which, if not avoided, could result in death or serious injury.

It may also be used to alert against unsafe practices.



Black letters on **YELLOW**

This signal word indicates a potentially hazardous situation which, if not avoided, will result in minor or moderate injury.

It may also be used to alert against unsafe practices.

# PECO LIMITED WARRANTY FOR NEW PRODUCTS

New PECO, Inc. extends the following warranties to the ORIGINAL PURCHASER of each New PECO, Inc. consumer product purchased from one of our Dealers or directly from New PECO, Inc., subject to the following limitations:

## **A. ITEMS COVERED UNDER WARRANTY**

1. **PRODUCT WARRANTY** – Any part or parts which are deemed defective in material or workmanship, as delivered to the original purchaser, will either be repaired or replaced, as New PECO, Inc. elects, without charge for parts or labor, if the defect appears within 12 months from the date of purchase of the product to the Original Purchaser.
2. **PARTS REPLACED DURING WARRANTY** – Any New PECO, Inc. part which is furnished in performance of this warranty and is defective in material or workmanship as delivered to the purchaser will be repaired or replaced, as New PECO, Inc. elects, before the expiration of the original warranty period.

## **B. WARRANTY DISTINCTIONS**

1. **RESIDENTIAL** - Products put to a personal use around a single household or residence are considered Residential. Products designated as “Residential” are warranted for 12 months from the date of purchase of the product, to the ORIGINAL PURCHASER with proof of purchase, when used for or in residential applications.
2. **COMMERCIAL** – Products put to any business use (agricultural, commercial or industrial) or used at multiple locations are considered Commercial. Products designated as “Commercial” are warranted for 12 months from the date of purchase of the product, to the ORIGINAL PURCHASER with proof of purchase, when used for or in commercial applications. Products designated as “Residential” are warranted for 90 days from the date of purchase of the product, to the ORIGINAL PURCHASER with proof of purchase, when used for or in Commercial applications.
3. **RENTAL** – Products used for Rental or Lease Purposes are warranted for 45 days from date of purchase of the product, to the ORIGINAL PURCHASER with proof of purchase, when used for or in a rental business.

## **C. ITEMS NOT COVERED BY NEW PECO WARRANTY**

1. **ENGINES & BATTERIES:** Engines and Batteries attached to New PECO, Inc. products are covered under their respective separate manufacturer warranties and those companies must be contacted directly to file a warranty claim. Briggs & Stratton: [https://www.briggsandstratton.com/na/en\\_us/support/warranty.html](https://www.briggsandstratton.com/na/en_us/support/warranty.html)
2. **UNAPPROVED ALTERATION OR MODIFICATION:** All obligations of New PECO, Inc. under this warranty shall be terminated if products are altered or modified in any way not approved by New PECO, Inc.
3. **ACCIDENTS & NORMAL MAINTENANCE:** This warranty covers ONLY manufacturers defective material and workmanship. It does not cover depreciation or damage caused by normal wear & tear, accident, improper maintenance, misuse or abuse of products. New PECO, Inc. products must be operated and maintained in accordance with the instructions furnished in the manuals. The cost of normal maintenance and normal replacement of service items such as belts, cutting blades, hoses, bags, etc., which are not defective shall be paid for by the purchaser.
4. **NO SERVICE CENTER WARRANTY:** The selling Service Center/Dealer makes no warranty on his own on any item warranted by New PECO, Inc. unless he delivers to purchaser a separate written warranty certificate specifically warranting the item. The Service Center or Dealer has no authority to make any representation or promise on behalf of New PECO, Inc. or to modify the terms of the original warranty in any way.
5. **NO REPRESENTATIONS ADDITIONAL WARRANTIES, DISCLAIMER:** Neither New PECO, Inc. nor any company affiliated with New PECO, Inc. makes any warranties, representations or promises as to the quality of performance of its products other than those set forth herein. Except as described above, New PECO, Inc. makes no other warranties **AND SPECIFICALLY DISCLAIMS ANY AND ALL IMPLIED WARRANTIES OF FITNESS AND MERCHANTABILITY.**
6. **REMEDIED EXCLUSIVE:** The only remedies the purchaser has in connection with the breach or performance of any warranty on New PECO, Inc. consumer products are set forth above. In no event will New PECO, Inc. be liable for special incidental or consequential damages.

Warranty service is available through your local authorized service dealer or distributor. If you do not know the dealer or distributor in your area, search by your zip code on [www.lawnvac.com](http://www.lawnvac.com) or contact our Sales Department at New PECO, Inc. 800-438-5823 or email [Sales@lawnvac.com](mailto:Sales@lawnvac.com).

# Section I - INTRODUCTION AND DESCRIPTION

## Introduction

We are pleased to have you as a PECO customer. Your collection system has been designed to give you a low maintenance, simple, and effective way to collect the grass clippings from your mower. The manuals are provided to give you the necessary instructions to properly mount, operate and maintain the collection system on your mower. Please read this manual thoroughly. Understand what each control is for and how to use it. Observe all safety decal precautions on the machine and noted throughout the manual.

**NOTE:** All references made to right, left, front, rear, top or bottom are as viewed from the normal operator's position on the mower.

## Description

The grass collection system is designed for turf maintenance where there is a need to collect the grass clippings as the mower cuts the turf. It is also used for picking up leaves in pre-season and post-season clean-up. The blower, mounted on the right side of the unit, uses a belt and gearbox system from the engine PTO shaft. Drive train protection comes through belt slippage. The blower draws grass clippings from the discharge area of the cutting deck back to the collection bags at the rear portion of the mower frame. The operator can engage the blower with a toggle switch mounted on the control panel to the right of the operator. Once the bags are full with clippings, they can be easily released for dumping.



**Engine Driven Unit Shown Above**

Note: Installations for specific units will be specified at the top right of the current section heading or where needed as:

**PTO-X**

or

**Engine Drive**

Text with instructions for a specific unit will be highlighted, with respect, to the color identified above as such: **PTO-X Drive** & **Engine Drive**.

PTO-X Units may also share similar instructions with the Engine Drive Units. The units sharing the same instructions will not have any specification under the section heading or highlighted within the text.

# Section II - INSTALLATION FOR USE

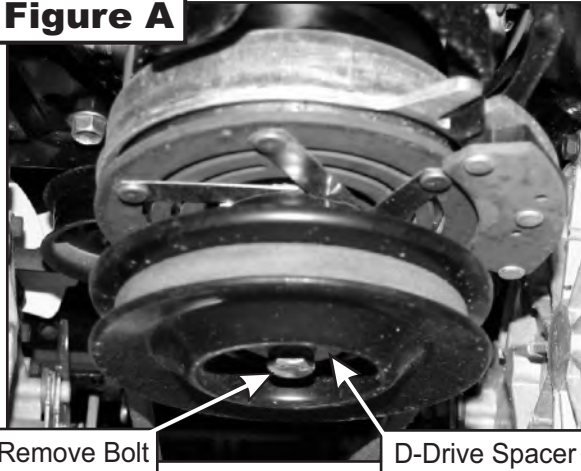
PTO-X

## Preparation Of Mower

**NOTE:** The mower deck PTO belt must be removed from the electric clutch before continuing with the installation. Refer to your mower's owner's manual for instructions on PTO belt removal.

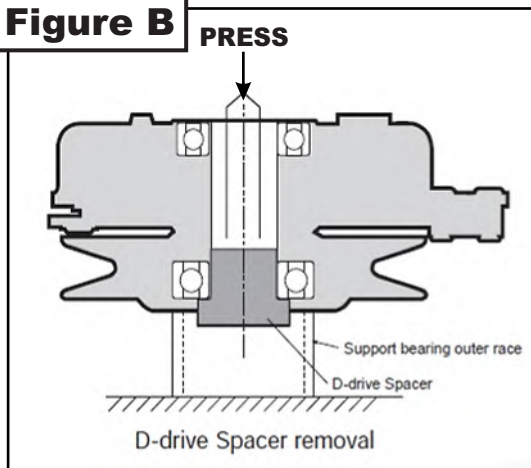
From the underside of the engine, disconnect the wiring harness attached to the electric clutch. Remove the bolt and electric clutch from the mower. Refer to Figure A.

**Figure A**

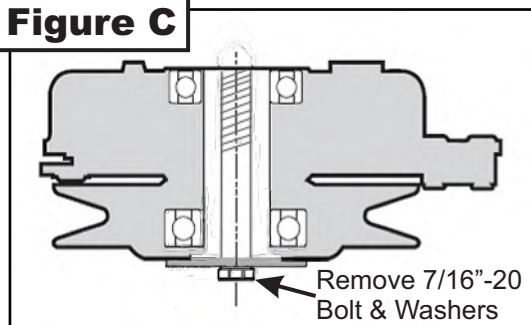


Upon removal of clutch determine if your mower is equipped with a D-drive spacer. If so, then proceed to Figure B. If your mower is equipped with bolt, fender and lock washer without D-drive spacer proceed to Figure C. Remove the D-drive spacer using an arbor press or equivalent. On removal, adjacent bearing OUTER race must be supported or bearing damage may occur. Refer to Figure B.

**Figure B**

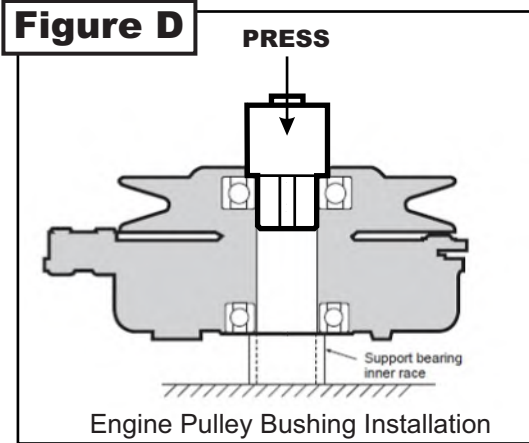


**Figure C**



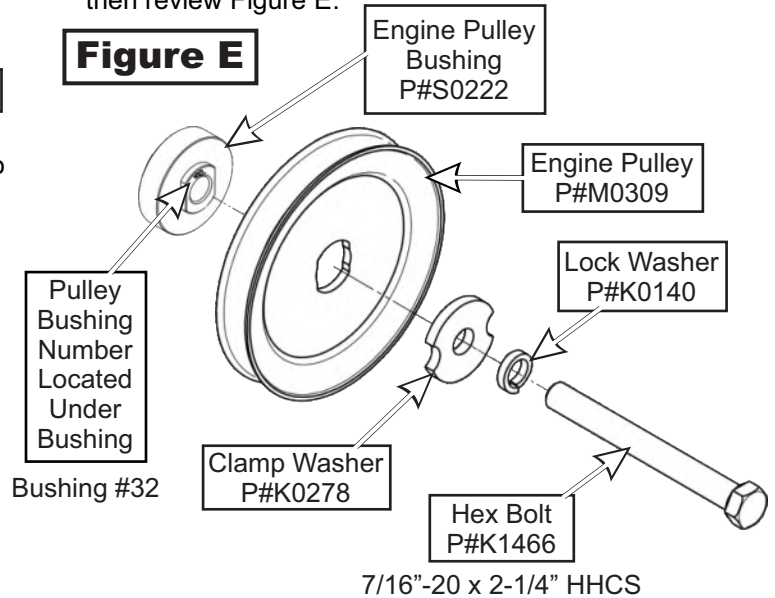
The engine pulley assembly must be installed using an arbor press or equivalent. During installation, opposite bearing inner race must be supported or bearing damage may occur. Refer to Figure D.

**Figure D**



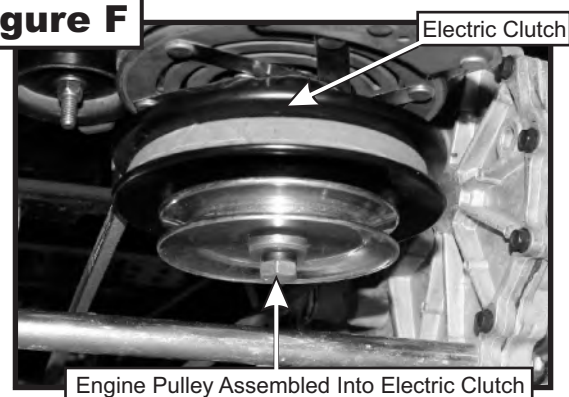
Once the Engine Pulley Bushing is installed, reattach the clutch assembly & deck PTO belt to the mower and then review Figure E.

**Figure E**



To assemble and fasten the Engine Pulley, align the Engine Pulley Bushing to the mower's clutch pulley and fasten using (1) Clamp Washer, (1) Lock Washer, and (1) Hex Bolt. Torque the bolt to 55 ft./lbs. The added pulley will power the collection system and should resemble Figure F when installed.

**Figure F**



## Rear Frame Bracket Installation

Before installing the Rear Frame Bracket (Item #1), first remove the (2) existing fasteners from the mower's rear bumper, see Figure A. Once removed, align the Rear Frame Bracket (Item #1) to the mower's rear bumper bolt holes. Secure the Rear Frame Bracket by using (4) 5/16"-18 x 1" Carriage Bolts (Item #2) & (4) 5/16"-18 Ny-Flange Lock Nuts (Item #3), see Figure B.

Note: Some parts and part features have been hidden from view for visual clarity.

Figure A

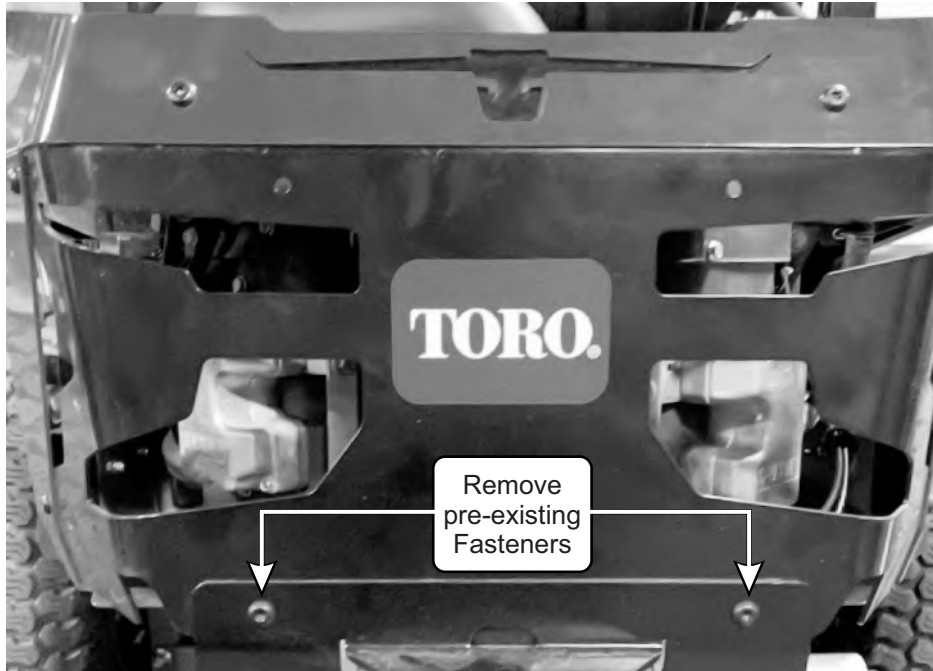
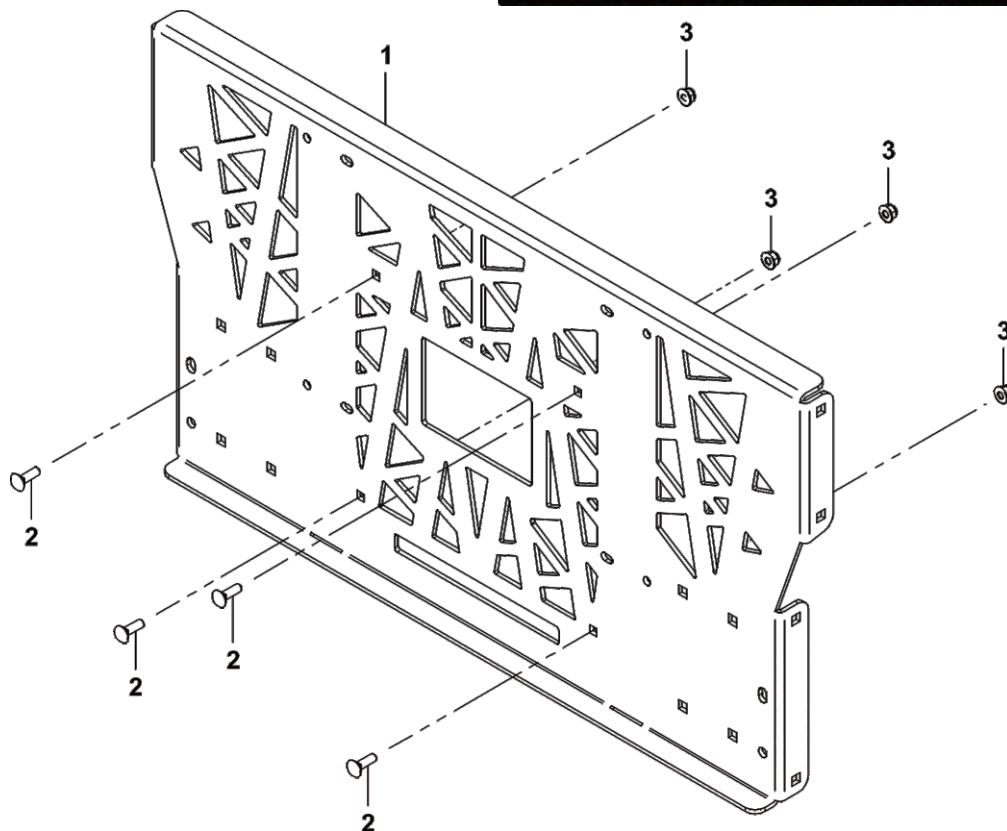


Figure B

Item #	Part #	Desc.	Qty.
1	B2119	Rear Frame Brkt.	1
2	K1144	5/16"-18 x 1" Carriage Bolt	4
3	K2516	Ny-Flange Lock Nut 5/16"-18	4



## Lower Frame Bracket Installation

First, remove and set aside the (2) set of fasteners on the bottom right side of the mower. Refer to Figure A.

Next, align the left most bolt holes of the Lower Rt. Frame Bracket (Item #1) to the lower right bolt holes of the Rear Frame Bracket. Then, secure the Lower Rt Frame Bracket by using (2) 3/8"-16 x 1" Carriage Bolts (Item #3) and (2) 3/8"-16 Ny-Flange Lock Nuts (Item #4). Refer to Figure B.

Finally, secure the (2) far right bolt holes of the Lower Rt Frame Bracket by using the previously removed fasteners. Repeat the procedures for the Lower Lt Frame Bracket (Item #2) on the opposite side. Refer to Figure B.

Note: Some parts and part features have been hidden from view for visual clarity.

Figure A

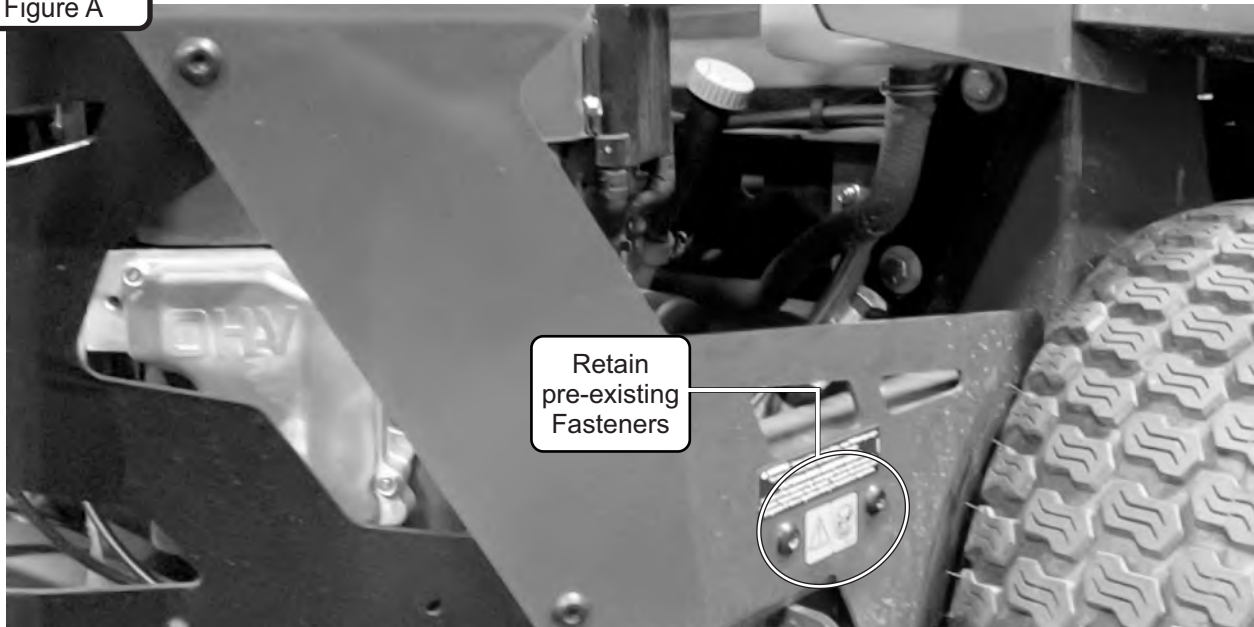
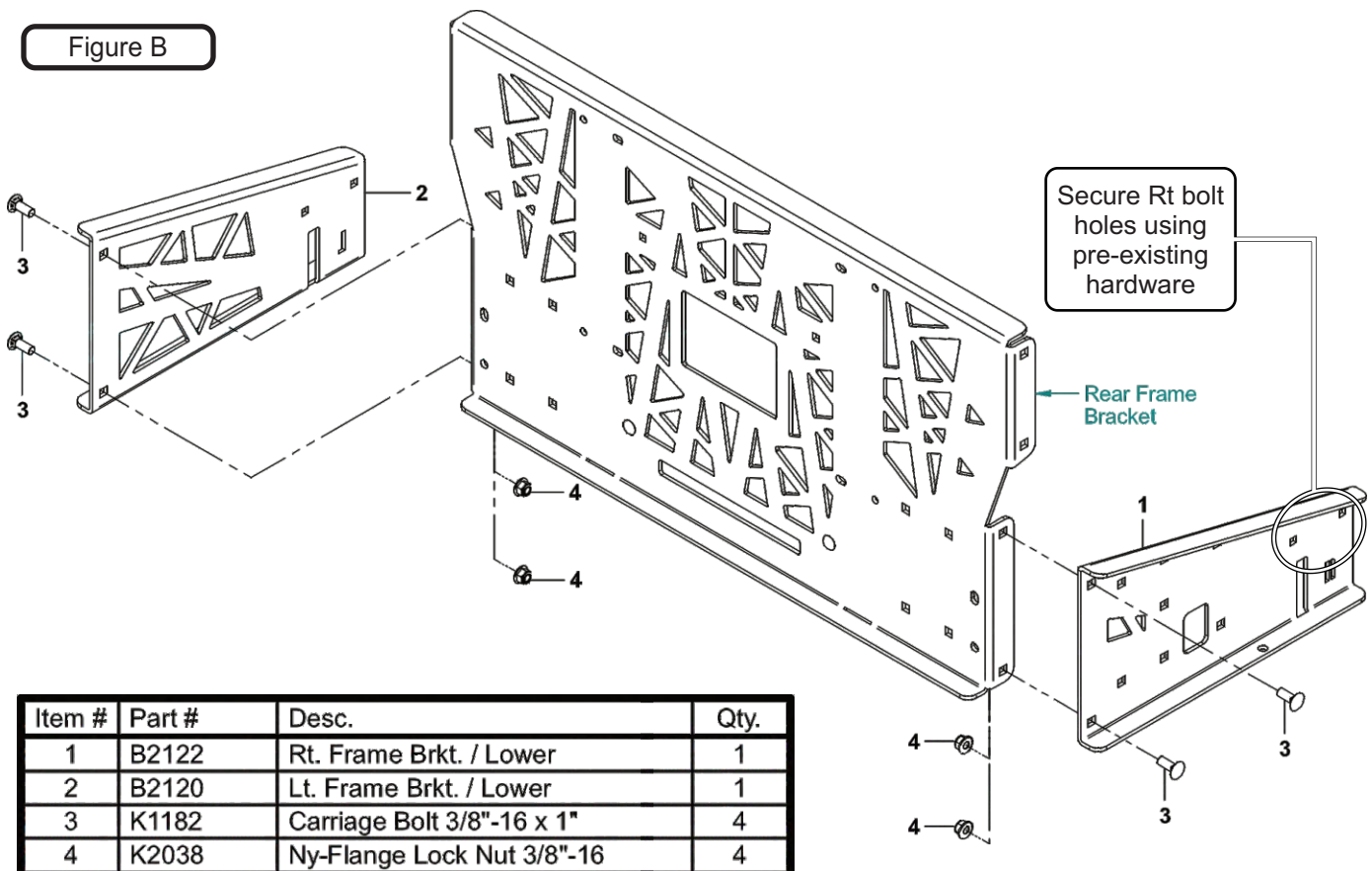


Figure B



Item #	Part #	Desc.	Qty.
1	B2122	Rt. Frame Brkt. / Lower	1
2	B2120	Lt. Frame Brkt. / Lower	1
3	K1182	Carriage Bolt 3/8"-16 x 1"	4
4	K2038	Ny-Flange Lock Nut 3/8"-16	4



## Upper Frame Bracket Installation

First, align the left most bolt holes of the Upper Right Frame Bracket (Item #1) to the upper right bolt holes of the Rear Frame Bracket. Then, secure the Upper Rt Frame Bracket to the Rear Frame Bracket relatively loose by using (2) 3/8"-16 x 1" Carriage Bolts (Item #3) and (2) 3/8"-16 Ny-Flange Lock Nuts (Item #4). Refer to Figure A.

Next, align the (2) right most bolt holes of the Upper Rt Frame Bracket between the mower's ROPS. Finally, secure the right side of the Upper Rt Frame Bracket by using (1) 3/8"-16 U-Bolt (Item #5) and (2) 3/8"-16 Ny-Flange Lock Nuts (Item #4). Tighten all hardware at this time. Repeat the procedures for the Upper Left Frame Bracket (Item #2) on the opposite side. See Figure B.

Note: Some parts and part features have been hidden from view for visual clarity.

Figure A

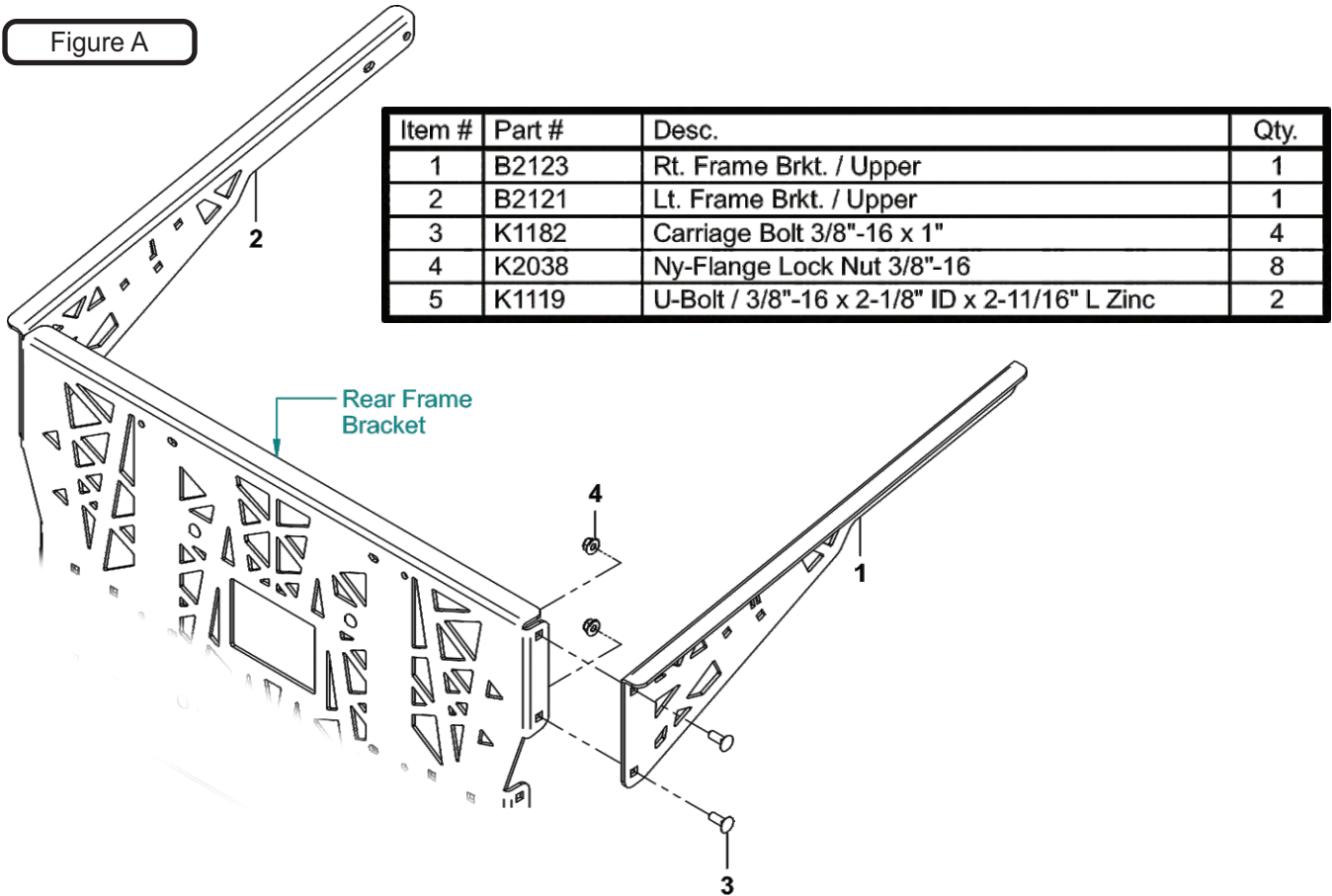
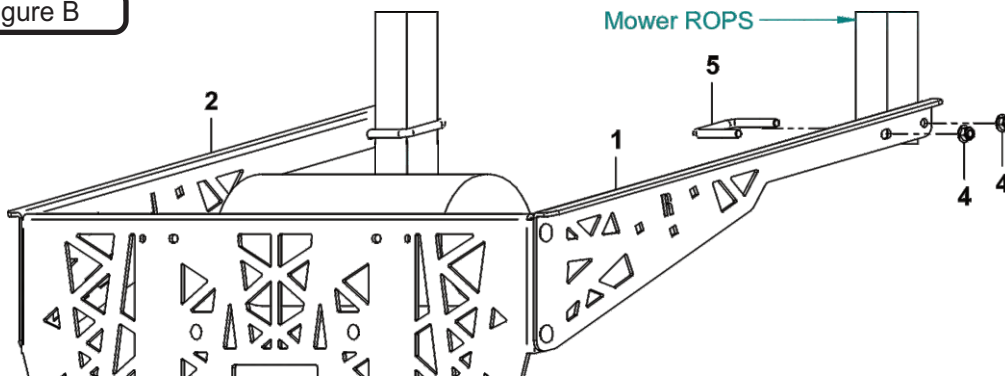


Figure B



## Frame Gusset Installation

Position the Frame Gusset (Item #1) behind the Rear Frame Bracket & Lower Right Frame Bracket aligning the bolt holes of the Frame Gusset to the top bolt holes of those on the Rear Frame Bracket & Lower Right Frame Bracket. Refer to Figure A.

Secure the Frame Gusset by using (3) 3/8"-16 x 1" Carriage Bolts (Item #2) and (3) 3/8"-16 Ny-Flange Lock Nuts (Item #3). Refer to Figure B.

For **Engine Driven Units**, only the top Frame Gusset is needed and will be fully secured during this step.

For **PTO-X Drive Units**, a second Frame Gusset needs to be installed below the top Frame Gusset. Repeat the same procedures for the second bottom Frame Gusset. Refer to Figure A & Figure B. The Frame Gussets for the **PTO-X Drive Units** will be fully secured during the PTO Mount Arm Installation on page 11.

**Note:** Some parts and part features have been hidden from view for visual clarity. The total amount of components needed for each specific Drive will be specified in Figure B within their respective Drive Specification.

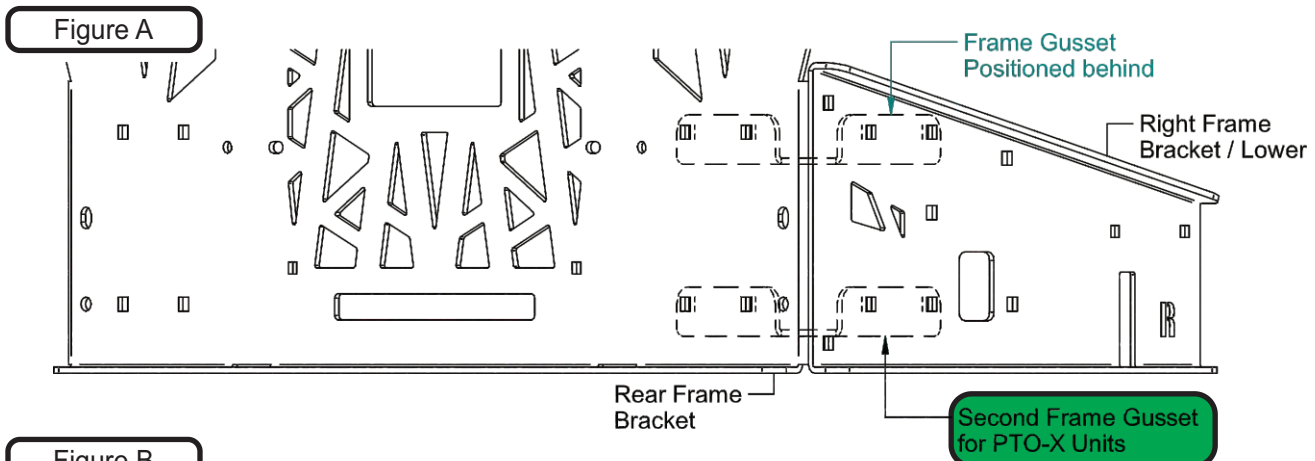


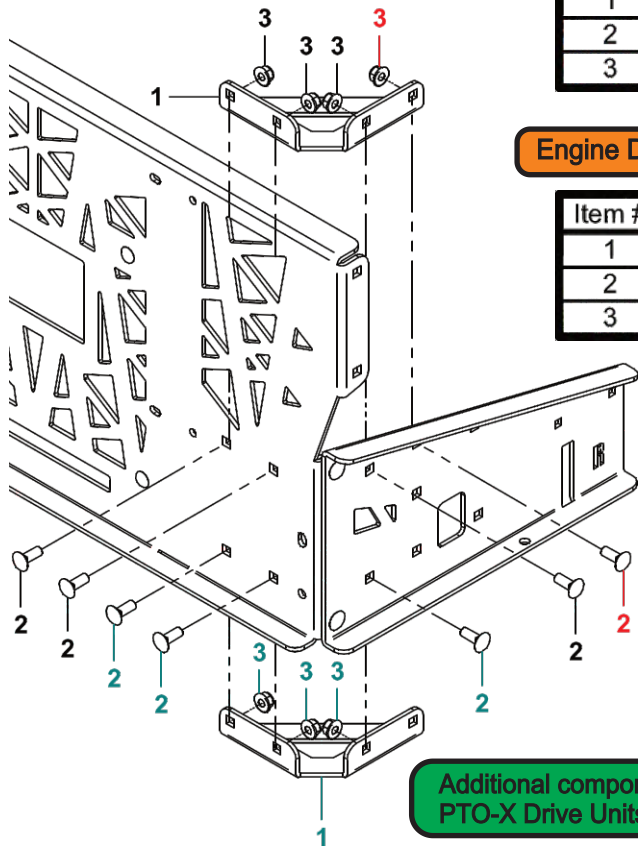
Figure B

### PTO-X

Item #	Part #	Desc.	Qty.
1	B2129	Frame Gusset	2
2	K1182	Carriage Bolt 3/8"-16 x 1"	7
3	K2038	Ny-Flange Lock Nut 3/8"-16	7

### Engine Drive

Item #	Part #	Desc.	Qty.
1	B2129	Frame Gusset	1
2	K1182	Carriage Bolt 3/8"-16 x 1"	4
3	K2038	Ny-Flange Lock Nut 3/8"-16	4



Additional component for PTO-X Drive Units

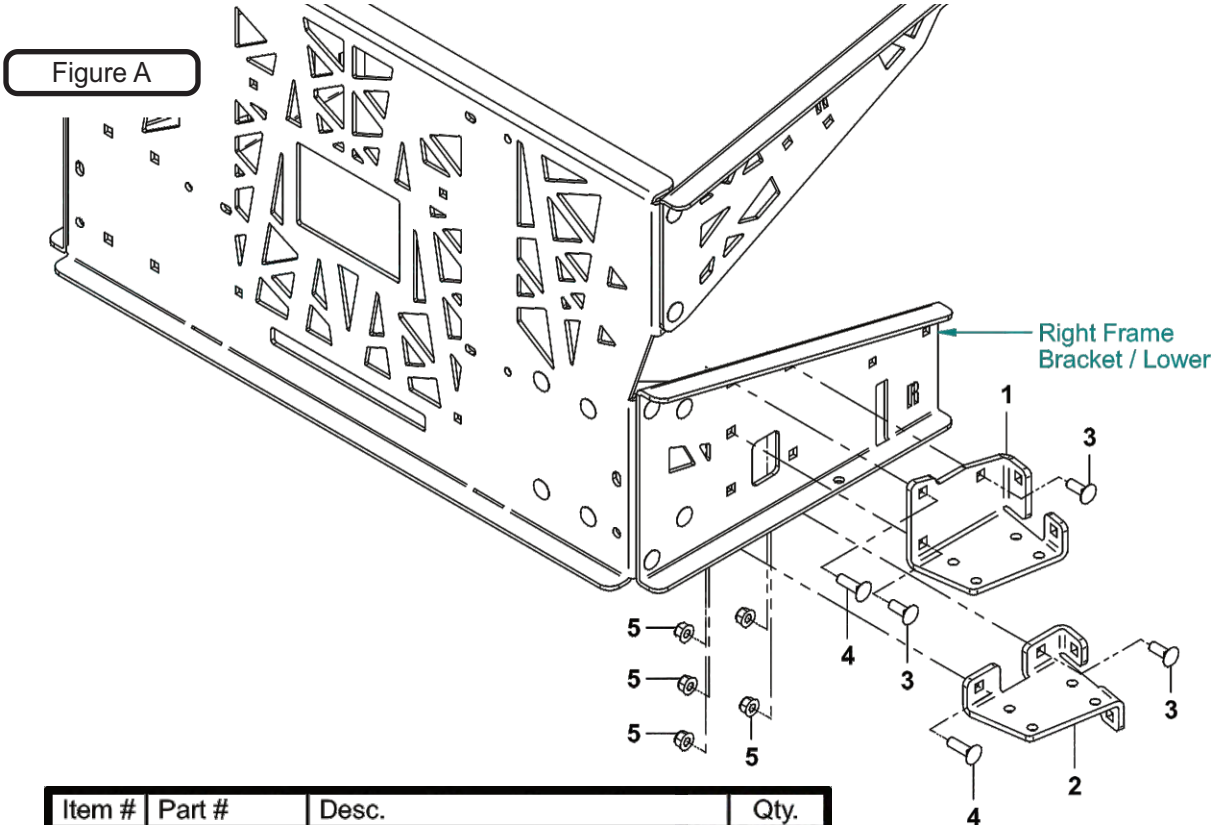
# PTO Mount Arm Installation

## PTO-X Unit Instructions

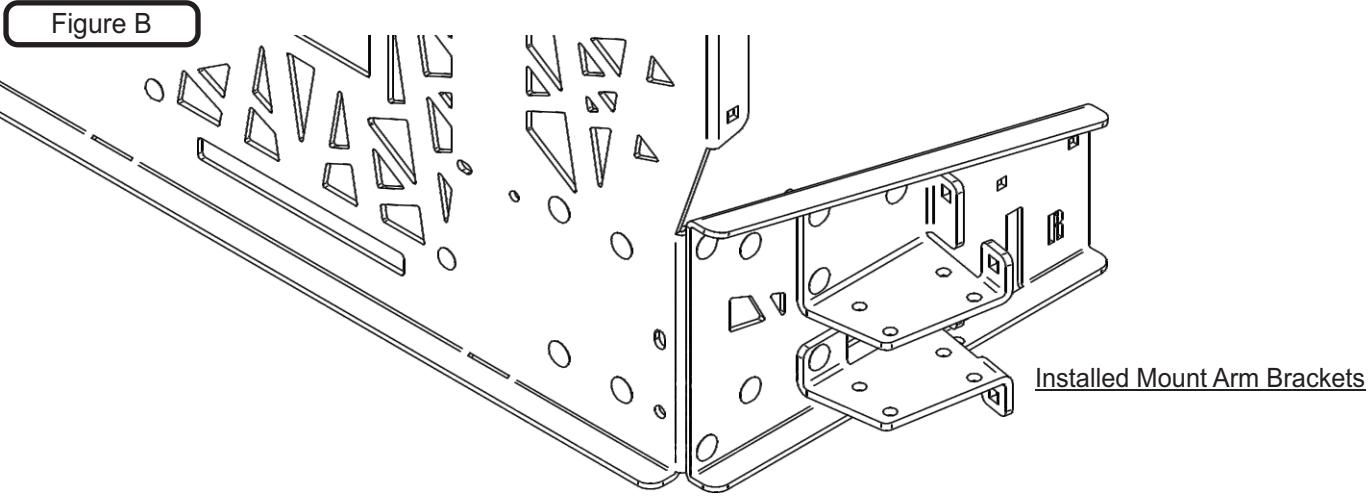
Position the Mount Arm / Top Bracket (Item #1) to the top center set of bolt holes. Secure the Mount Arm / Top Brkt, relatively loose, by using (2) 3/8"-16 x 1" Carriage Bolts (Item #3), (1) 3/8"-16 x 1-1/4" Carriage Bolts (Item #4) and (3) 3/8"-16 Ny-Flange Lock Nuts (Item #5). Refer to Figure A & Figure B below.

Position the Mount Arm / Bottom Bracket (Item #2) to the lower center set of bolt holes. Secure the Mount Arm / Bottom Brkt, relatively loose, by using (1) 3/8"-16 x 1" Carriage Bolts (Item #3), (1) 3/8"-16 x 1-1/4" Carriage Bolts (Item #4) and (2) 3/8"-16 Ny-Flange Lock Nuts. Refer to Figure A & Figure B below. Keep the hardware relatively loose until after the installation of the Mount Arm Gusset on pg 12.

Note: Some parts and part features have been hidden from view for visual clarity.



Item #	Part #	Desc.	Qty.
1	B2124	Mount Arm / Top Brkt.	1
2	B2125	Mount Arm / Bottom Brkt.	1
3	K1182	Carriage Bolt 3/8"-16 x 1"	3
4	K1183	Carriage Bolt 3/8"-16 x 1-1/4"	2
5	K2038	Ny-Flange Lock Nut 3/8"-16	5



## PTO Mount Arm Installation (Continued)

PTO-X

Position the Mount Arm / Gusset (Item #1) to the right of the Mount Arm / Top Bracket (Item #2) and Mount Arm / Bottom Bracket (Item #3). See Figure C. Secure the Mount Arm / Gusset, by using (4) 3/8"-16 x 1" Carriage Bolts (Item #4) and (4) 3/8"-16 Ny-Flange Lock Nuts (Item #5). Refer to Figure C & Figure D below.

Figure C

Item #	Part #	Desc.	Qty.
1	B2126	Mount Arm / Gusset	1
2	B2124	Mount Arm / Top Brkt.	1
3	B2125	Mount Arm / Bottom Brkt.	1
4	K1182	Carriage Bolt 3/8"-16 x 1"	4
5	K2038	Ny-Flange Lock Nut 3/8"-16	4

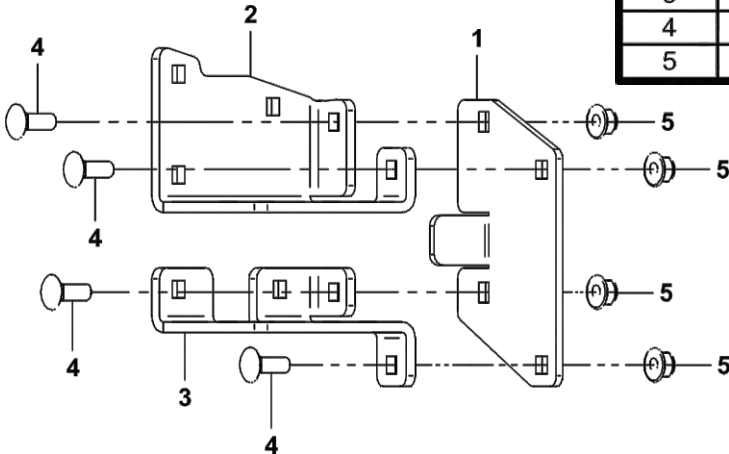
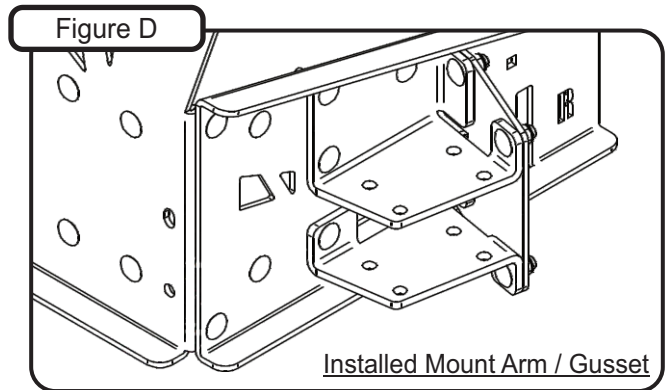


Figure D



Place the Receiver Tube Assembly (Item #1) between the Top & Bottom Mount Arm Brackets, see Figure E. Position the Receiver Tube Assy back onto the tab of the Mount Arm Gusset and between the bolt holes of the Top & Bottom Mount Arm Bracket, see Figure E and Figure F. Secure the Receiver Tube Assy by using (4) 3/8"-16 x 3.5" HHCS (Item #2) and (4) 3/8"-16 Ny-Flange Lock Nuts (Item #3). Refer to Figure E.

Figure E

Item #	Part #	Desc.	Qty.
1	A2207	Receiver Tube Assy. / Mount Arm	1
2	K1200	3/8"-16 x 3.5" HHCS G5	4
3	K2038	Ny-Flange Lock Nut 3/8"-16	4

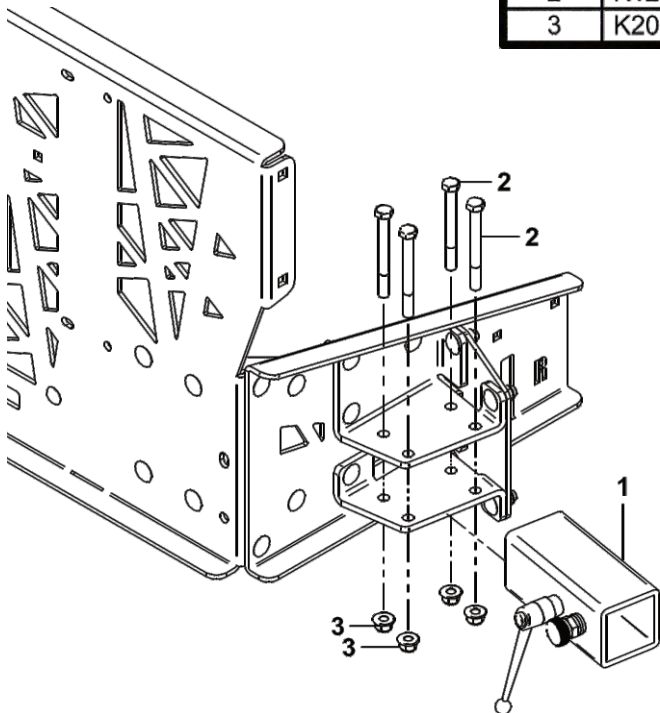
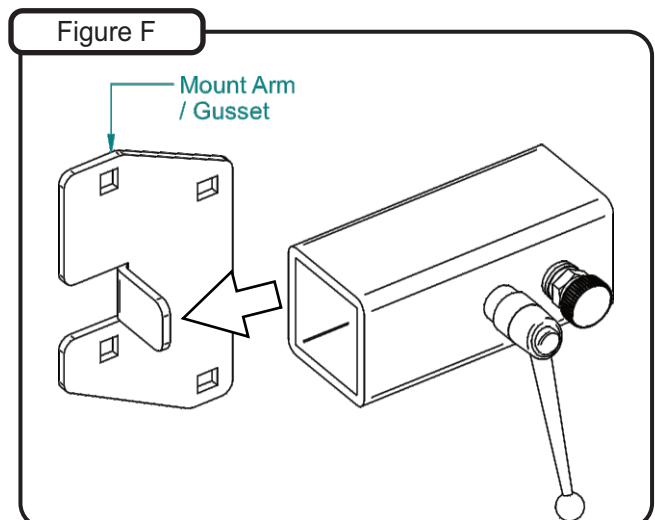


Figure F



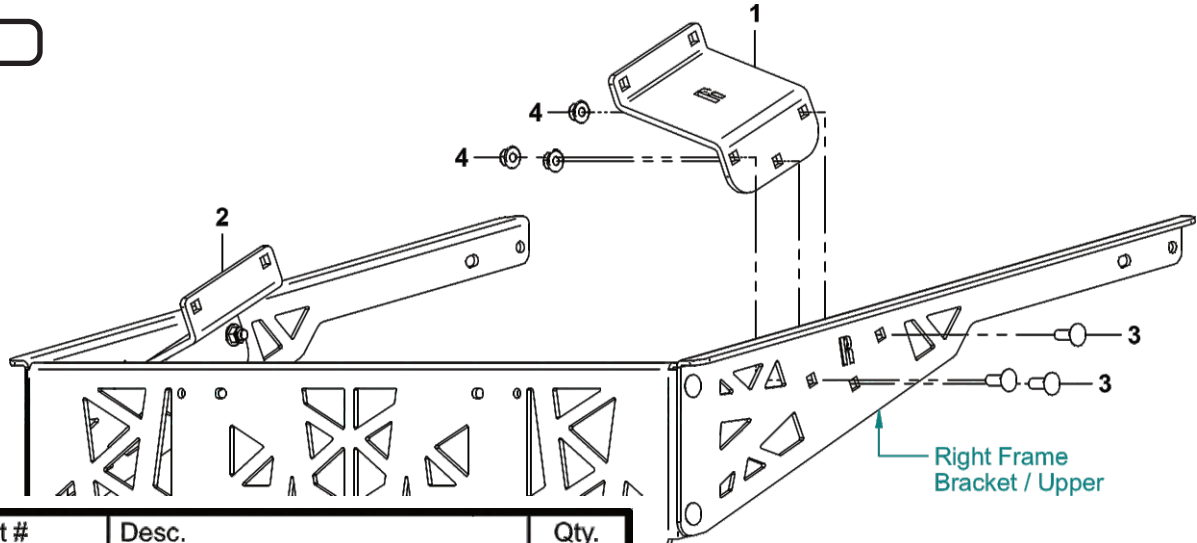
## Main Frame Leg Installation

To install the Right Main Frame Leg (Item #1), position the Right Main Frame Leg to the inside of the Upper Right Frame Bracket. Align the bolt holes of the Right Main Frame Leg to those on the Upper Right Frame Bracket. See Figure A. Secure the Right Main Frame Leg by using (3) 3/8"-16 x 1" Carriage Bolts (Item #3) and (3) 3/8"-16 Ny-Flange Lock Nuts (Item #4). See Figure A.

Repeat the same procedures for the installation of the Left Main Frame Leg (Item #2).

Note: Some parts and part features have been hidden from view for visual clarity.

Figure A

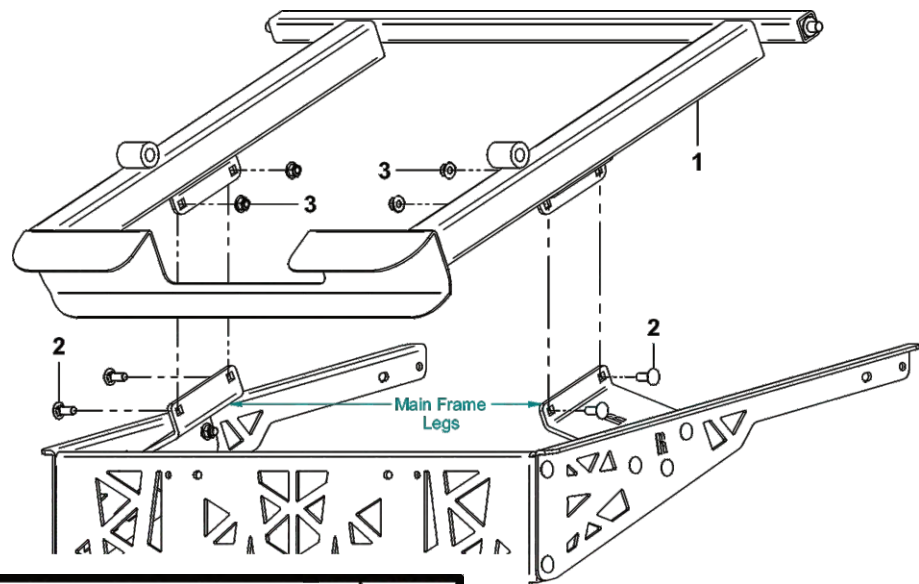


Item #	Part #	Desc.	Qty.
1	B2128	Rt. Main Frame Leg	1
2	B2127	Lt. Main Frame Leg	1
3	K1182	Carriage Bolt 3/8"-16 x 1"	6
4	K2038	Ny-Flange Lock Nut 3/8"-16	6

## Main Frame Assembly Installation

To install the Main Frame Assembly (Item #1), position the Main Frame Assy between both the Left & Right Main Frame Legs as shown in Figure A. Align the mounting holes of the Main Frame Assy to those on the Main Frame Legs and secure the Main Frame Assy by using (2) 3/8"-16 x 1" Carriage Bolts (Item #2) and (2) 3/8"-16 Ny-Flange Lock Nuts (Item #3) PER side. See Figure A.

Figure B



Item #	Part #	Desc.	Qty.
1	A1192	Main Frame Assembly	1
2	K1182	Carriage Bolt 3/8"-16 x 1"	4
3	K2038	Ny-Flange Lock Nut 3/8"-16	4

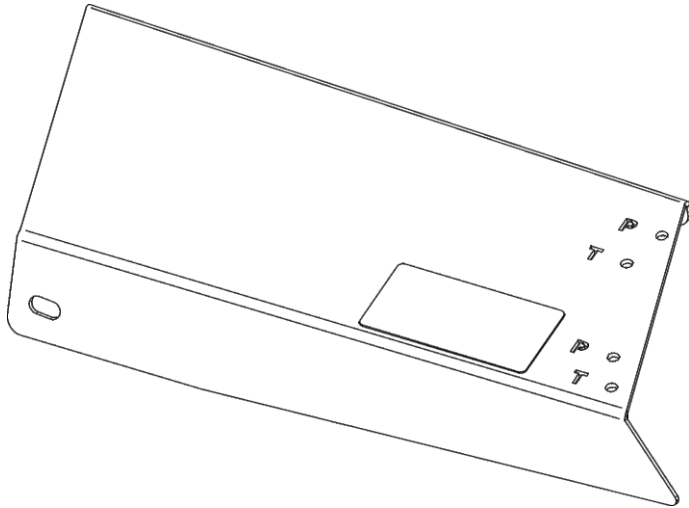
# PTO Drive Assembly

PTO-X

## PTO-X Unit Instructions

Once the Mount Arm Assembly is installed and secured to the mower, assemble the Drive Assembly P#(A2061\_03), Belt Guard Assembly P#(A2069\_02) & Idler Mount Assembly P#(A2067\_02).

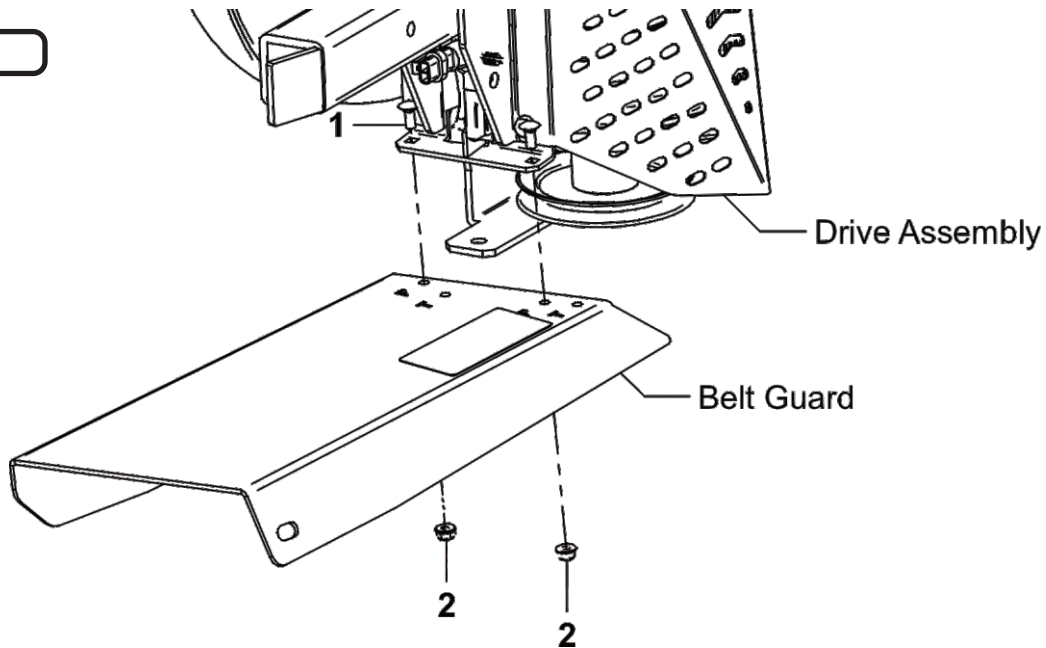
First, attach the Belt Guard Assembly P#(A2069\_02) to the Drive Assembly P#(A2061\_03) using (2) 1/4"-20 x 5/8" Carriage Bolts P#(K1010) and (2) 1/4"-20 Ny-Flange Lock Nuts P#(K2014). Refer to Figure A. **Leave Bolts Loose.**



### **BELT GUARD ASSY. HOLES**

Notice Marked Holes Below;  
For This Installation, Use Holes  
Marked With The Letter 'P'

Figure A



Item #	Part #	Desc.	Qty.
1	K1010	1/4"-20 x 5/8" Carriage Bolt	2
2	K2014	1/4"-20 Ny-Flange Lock Nut	2

## PTO Drive Assembly (Continued)

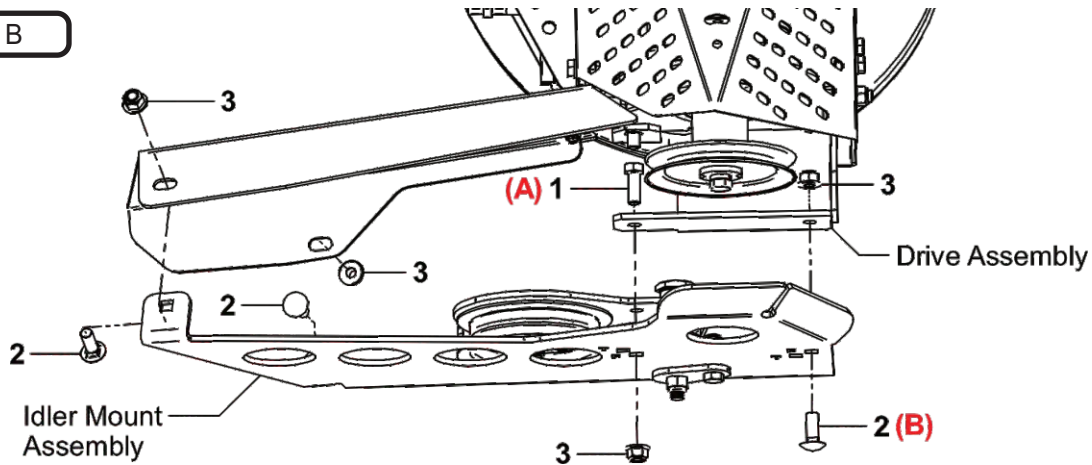
PTO-X

Attach the Idler Mount Assembly P#(A2067\_02) to the Drive Assembly using (1) 3/8"-16 x 1" HHCS (A) (Item #1), (1) 3/8"-16 x 1" Carriage Bolt (B) (Item #2) and (2) 3/8"-16 Ny-Flange Lock Nuts (Item #3). Refer to Figure B.

Leave Bolts Loose (Note: Orientation of bolts A & B.)

Next, secure the Idler Mount Assembly P#(A2067\_02) to the Belt Guard Assembly P#(A2069\_02) using (2) 3/8"-16 x 1" Carriage Bolts (Item #2) and (2) 3/8"-16 Ny-Flange Lock Nuts (Item #3). Refer to Figures C & D. Tighten All Bolts.

Figure B



Item #	Part #	Desc.	Qty.
1	K1191	HHCS 3/8"-16 x 1" GR5	1
2	K1182	Carriage Bolt 3/8"-16 x 1"	3
3	K2038	Ny-Flange Lock Nut 3/8"-16	4

Figure C

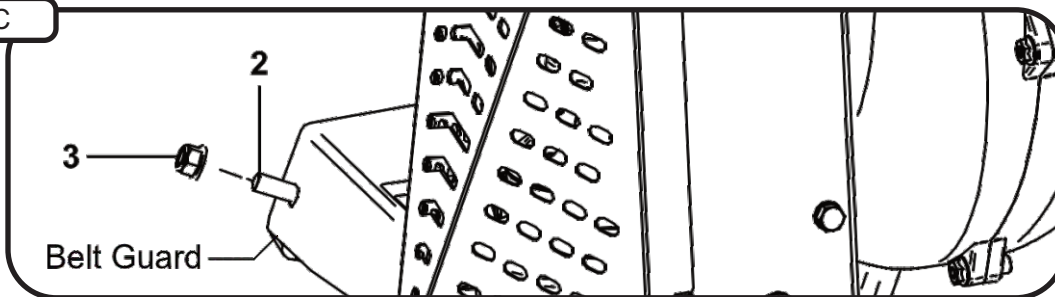
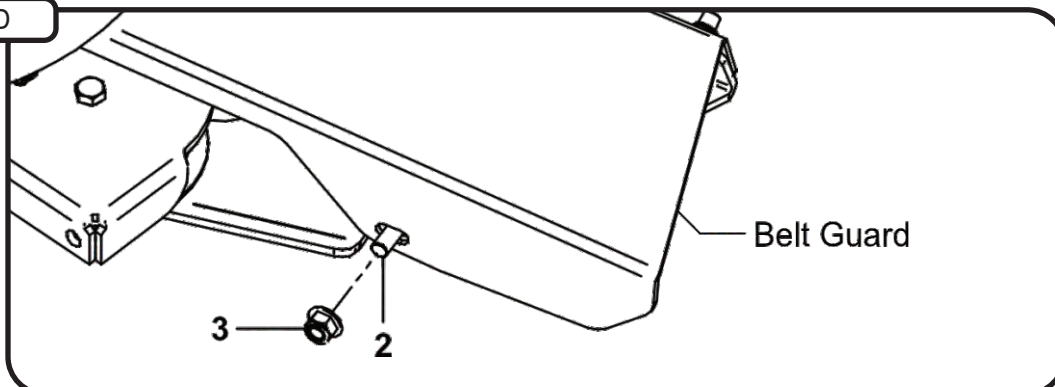


Figure D



# Drive Assembly and Belt Installation

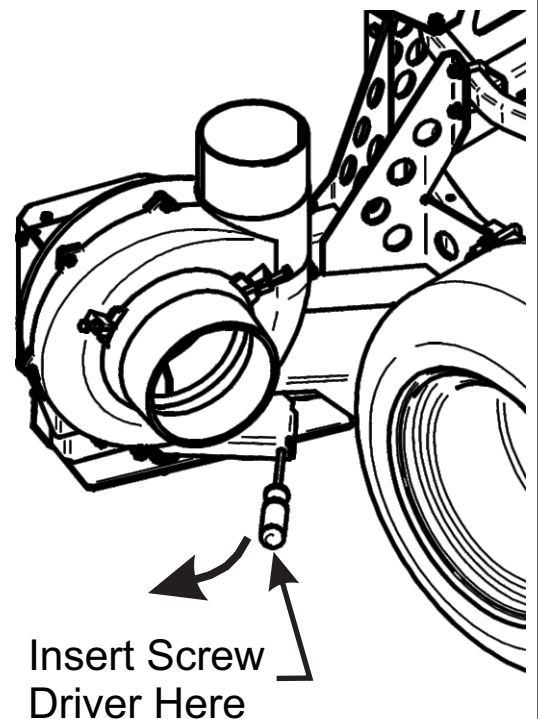
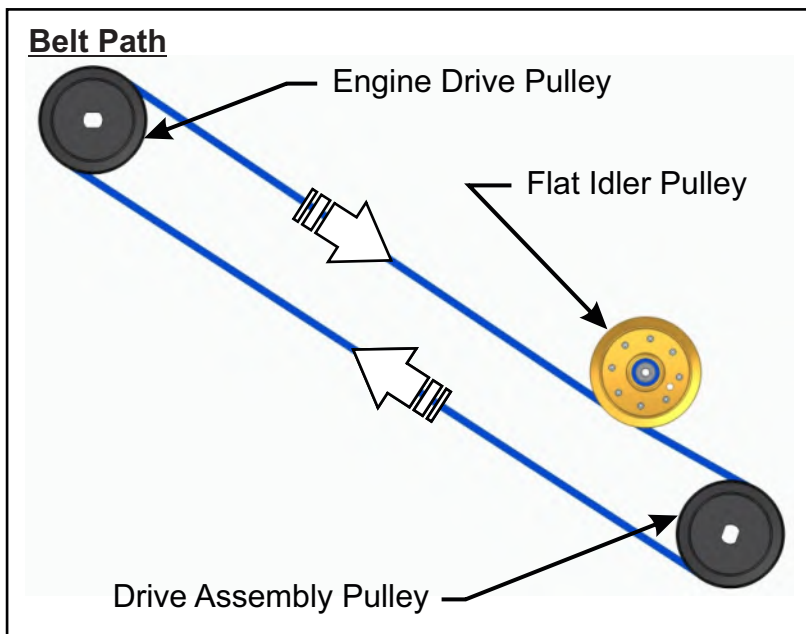
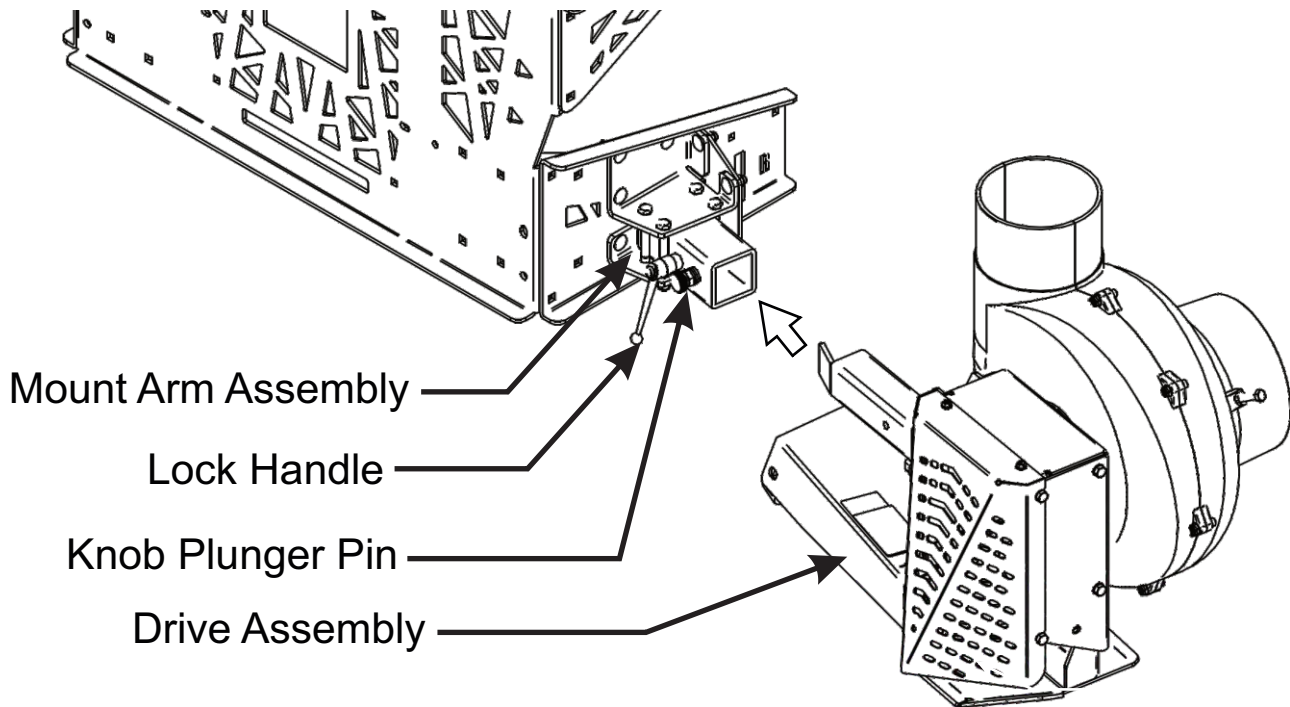
PTO-X

## PTO-X Unit Instructions

(Note: It is recommended that someone assist during this step.)

Insert the Drive Assembly into the receiver tube on the Mount Arm Assembly until the Knob Plunger Pin engages. Once in place, turn Lock Handle clockwise until tight. Next, feed the AK77 Belt P#(M0318) between the Belt Guard and the Idler Mount Assembly. Place belt around the Engine Drive Pulley on the underside of the mower. While one person inserts a screw driver (or similar tool) into the Idler Mount Assembly and rotates lever arm clockwise, enough to relieve all tension from belt, place belt around the Drive Assembly Pulley. Once the belt is in position, carefully release the tension to tighten belt.

Refer to the images below.





## Belt Tension Adjustment

PTO-X

The following information provides you a step by step guide on how to position the PTO-X Drive to obtain proper belt tension before use. Failure to set proper belt tension can result in drive damage and frequent belt replacements.

In order to properly tension your belt you will need the following tools:

- Impact Wrench
- 9/16" Socket
- 9/16" Open-End Wrench
- 7/16" Open-End Wrench
- Gates Tension Gauge (See Figure A)
- Tape Measure
- Marking Pen

Figure A

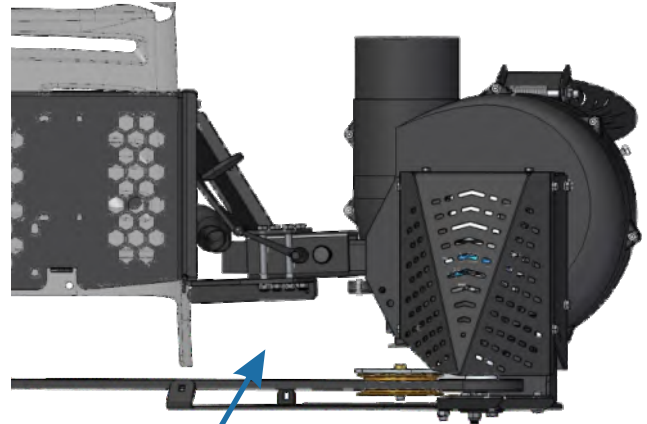
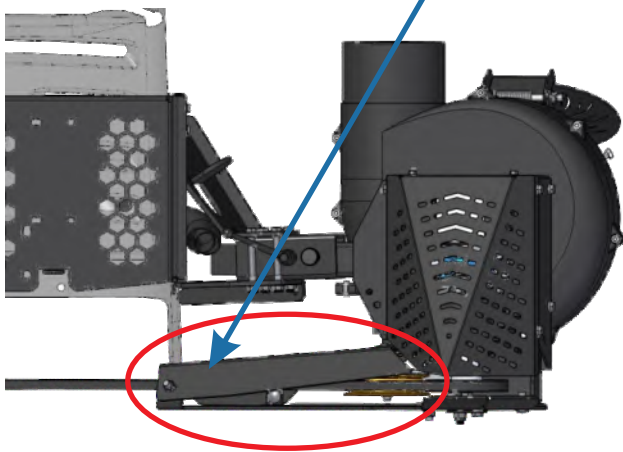
Gates Tension Gauge



**Step 1** - Remove the top belt guard from the drive assembly. See Figure B.

Figure B

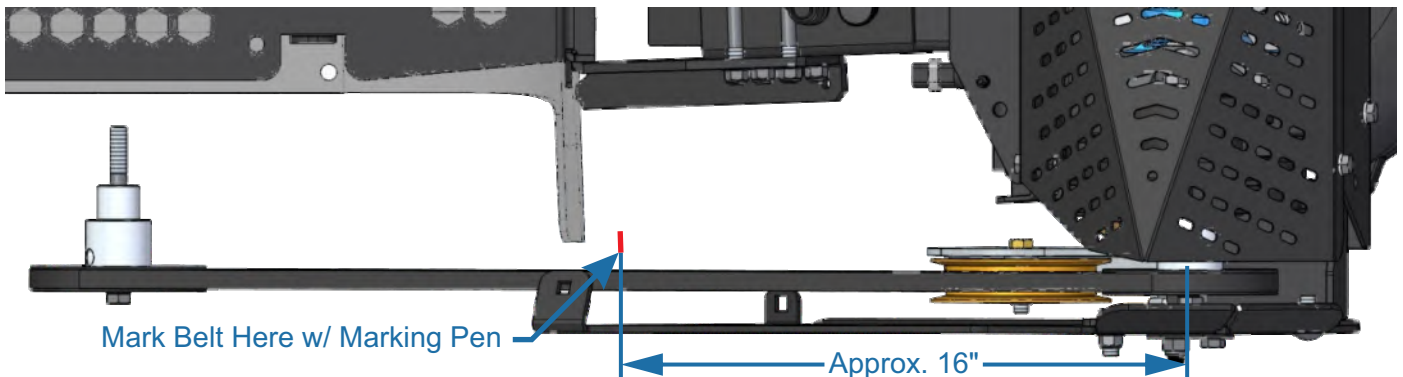
Top Belt Guard



Belt Guard Removed

**Step 2** - Using a measuring tape, measure from the pulley center to approximately 16" and lightly mark a line on the belt using a marking pen. See Figure C.

Figure C



## Belt Tension Adjustment (Cont.)

PTO-X

**Step 3** - Place index finger into the loop on the Gates tension gauge. Position your finger over the line marked previously and keep the lower lip of the gauge below the belt. See Figure D.

Press inward until you feel a click. Remove the gauge and see the next step on how to determine the reading.

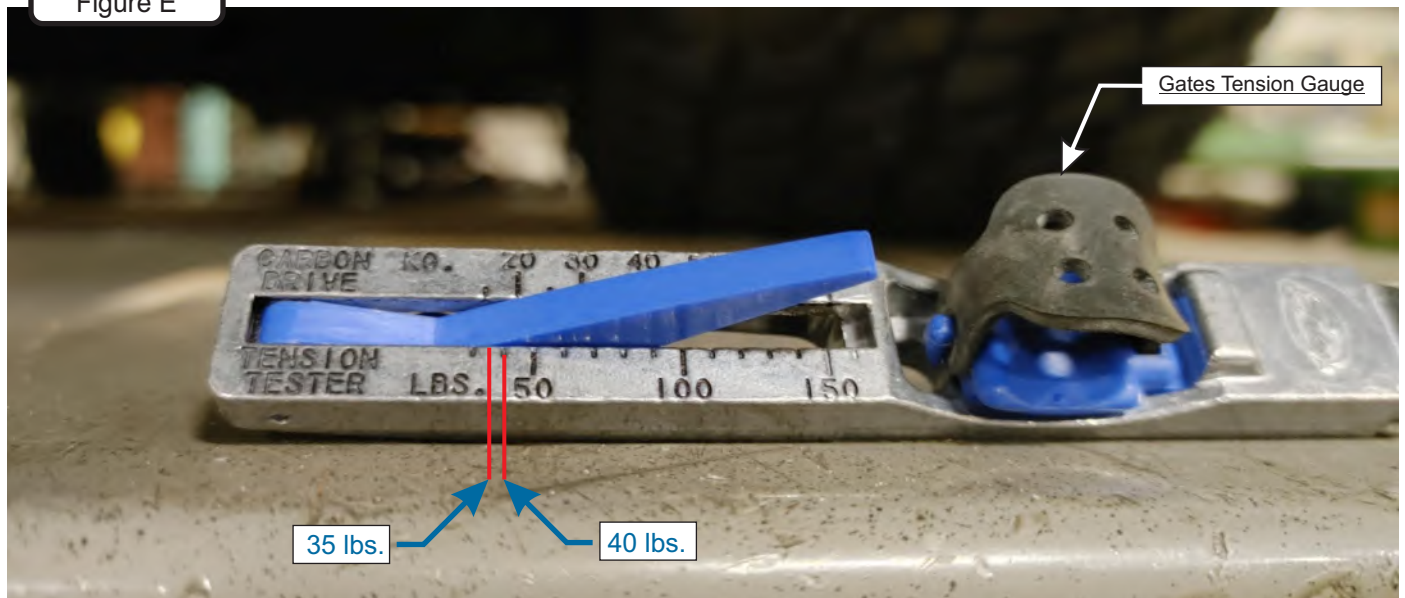
Figure D



**Step 4** - To determine the tension, position the gauge at an angle to see where the edge of the blue dial intersects with the gauge markings. In Figure E below, the gauge is reading approximately 35 lbs. of tension.

The proper belt tension should measure between 35 lbs. minimum and 40 lbs. maximum. If your reading is within this range, you can replace the top belt guard and forego the next steps.

Figure E



# Belt Tension Adjustment (Cont.)

## Step 5 - Belt Tension Procedure To Achieve 35-40 lbs. Tension

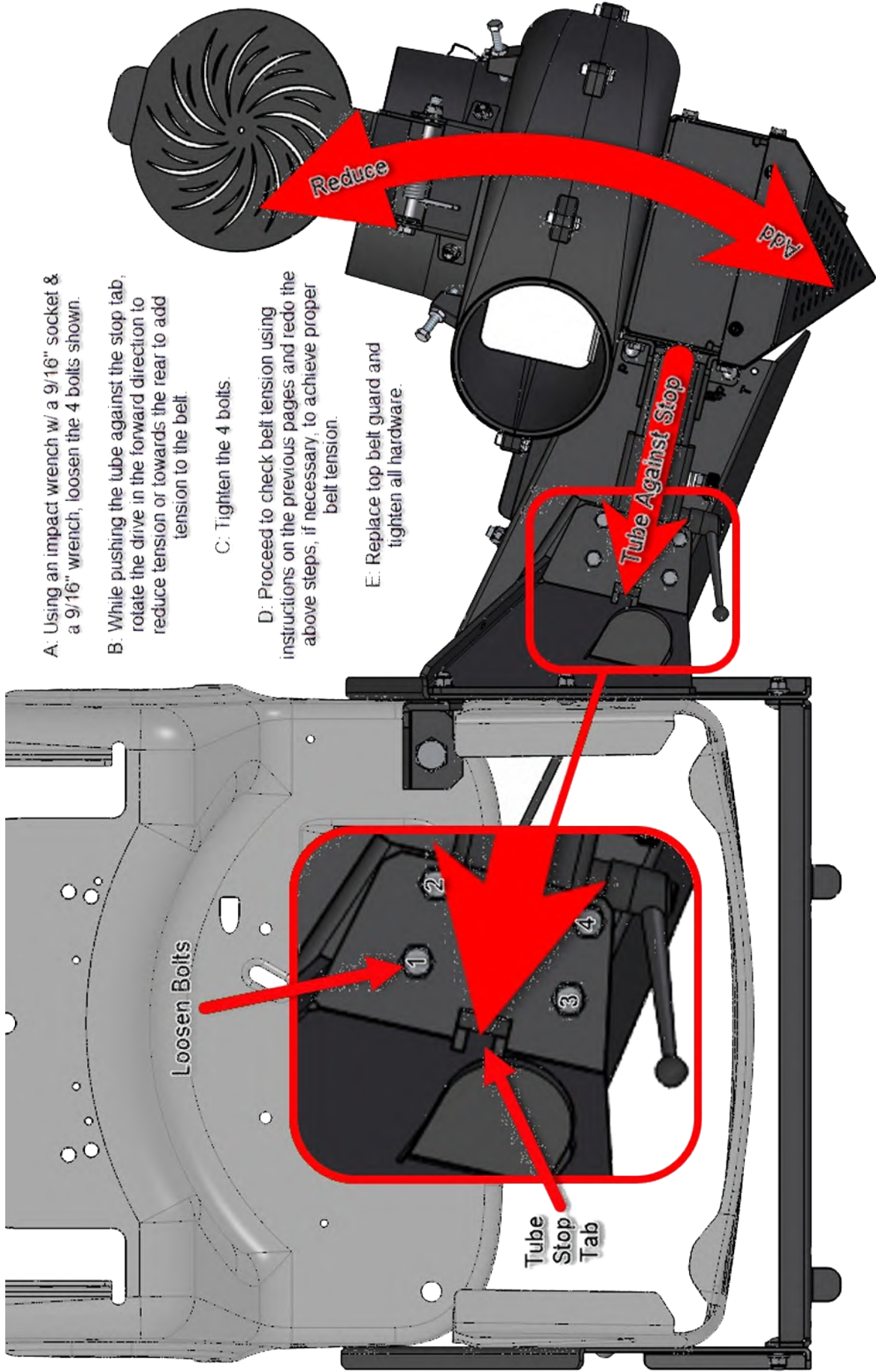
A: Using an impact wrench w/ a 9/16" socket & a 9/16" wrench, loosen the 4 bolts shown.

B: While pushing the tube against the stop tab, rotate the drive in the forward direction to reduce tension or towards the rear to add tension to the belt.

C: Tighten the 4 bolts.

D: Proceed to check belt tension using instructions on the previous pages and redo the above steps, if necessary, to achieve proper belt tension.

E: Replace top belt guard and tighten all hardware.



# Engine Mount Arm Assembly & Installation

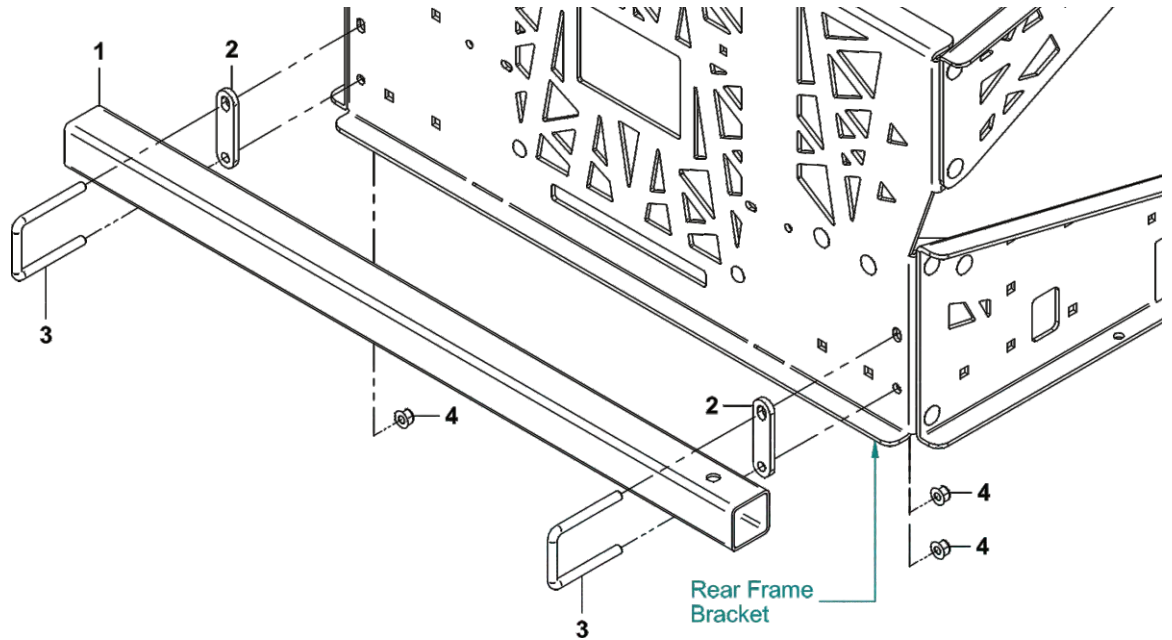
Engine Drive

## Engine Driven Unit Instructions

Position the Outer Engine Mount Tube (Item #1) above the tab of the Rear Frame Bracket aligning the Outer Tube between the two sets of mount holes as shown in Figure A. Secure the Outer Engine Mount Tube, relatively loose, by using (2) 3/8"-16 x 2-1/8" U-Bolts (Item #2) and (4) 3/8"-16 Ny-Flange Lock Nuts (Item #3). Once secured, adjust the Outer Engine Mount Tube positioning by moving it to the right until the right edge protrudes no more than 2-1/2" from the side of the Rear Frame Bracket. Once adjusted, tighten all hardware.

Note: Some parts and part features have been hidden from view for visual clarity.

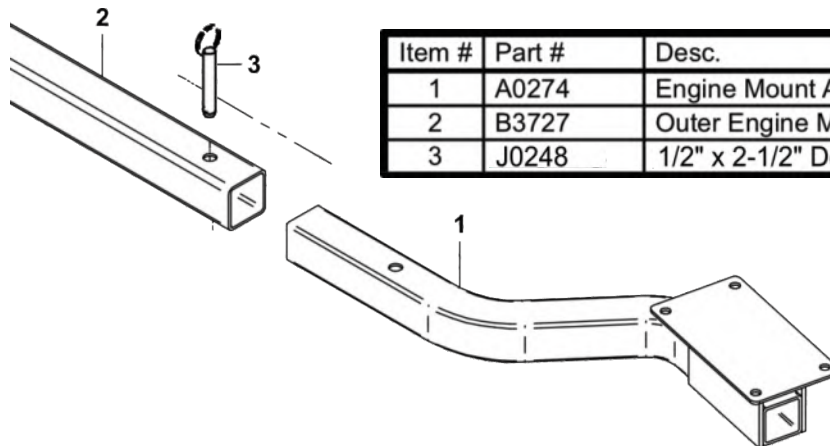
Figure A



Item #	Part #	Desc.	Qty.
1	B3727	Outer Engine Mount Tube	1
2	B2204	Engine Mount Arm Spacer	2
3	K1460	U-Bolt 3/8-16 X 2-1/8 X 3-3/8	2
4	K2038	Ny-Flange Lock Nut 3/8"-16	4

Insert the Engine Mount Arm Assembly (Item #1) into the Outer Engine Mount Tube (Item #2) and position the mounting pin hole between the two parts. Secure the Engine Mount Arm Assy by using (1) Detent Pin (Item #3). Refer to Figure B below.

Figure B



Item #	Part #	Desc.	Qty.
1	A0274	Engine Mount Arm Assy.	1
2	B3727	Outer Engine Mount Tube	1
3	J0248	1/2" x 2-1/2" Detent Pin	1

# Engine Drive Assembly Installation

Engine Drive

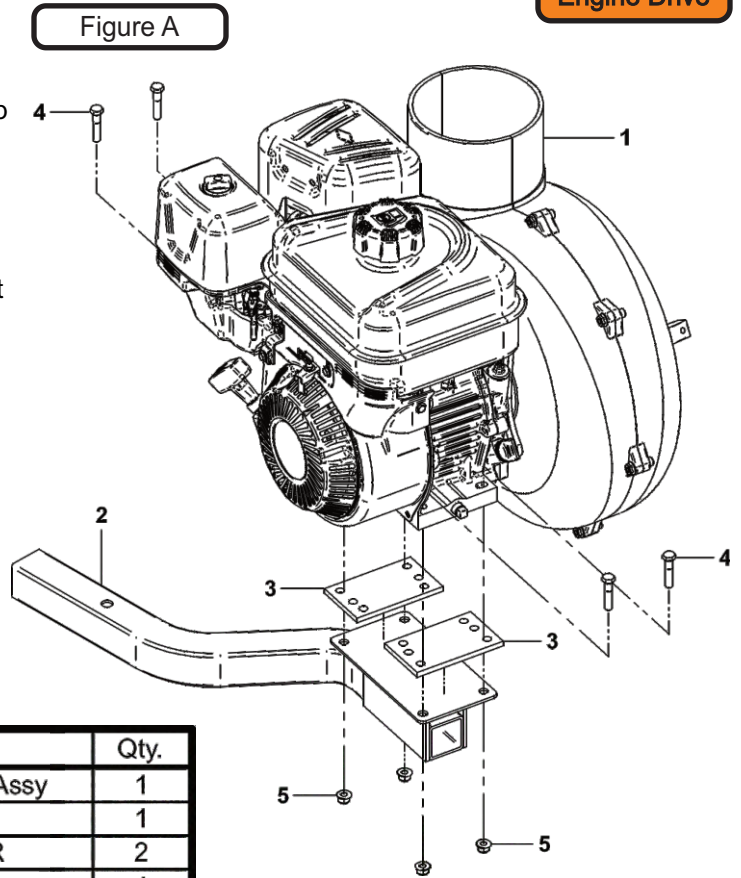
## Engine Driven Unit Instructions

First, place (2) Rubber Shock Absorbers (Item #3) on top of the Engine Mount Arm Assembly (Item #2) aligning the bolt holes of the Rubber Shock Absorbers to those on the Engine Mount Arm Assy.

Next, position and place the 6.5HP Engine Assembly (Item #1) on top of the Shock Absorbers aligning the bolt holes of all the components.

Finally, secure the Engine by using (4) 5/16"-18 x 2" HHCS (Item #4) and (4) 5/16"-18 Nyloc Nuts (Item #5). Refer to Figure A.

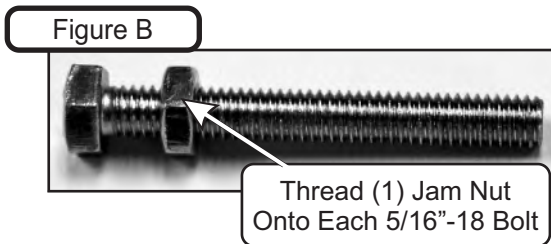
Note: Some parts and part features have been hidden from view for visual clarity.



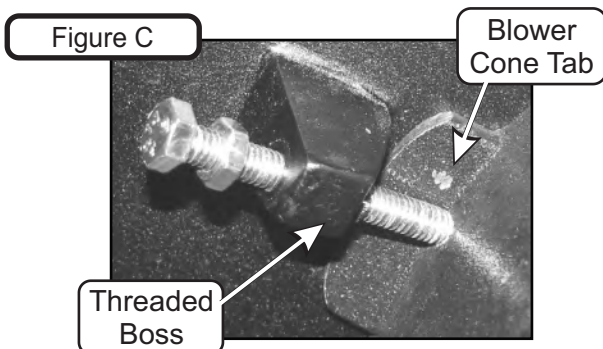
Item #	Part #	Desc.	Qty.
1	A639	BR6.5V Engine/Blower/Blade Assy	1
2	A0274	Engine Mount Arm Assy.	1
3	V1090	RUBBER SHOCK ABSORBER	2
4	K1159	5/16"-18 x 2" All Thread HHCS	4
5	K1180	5/16"-18 Nyloc Nut	4

## Blower Cone Installation

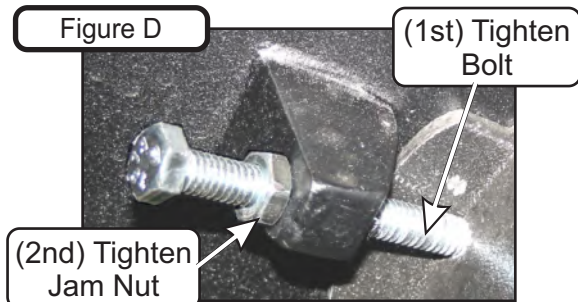
Thread (1) 5/16"-18 Jam Nut P#(K0120) onto each end of (2) 5/16"-18 x 2-1/2" HHCS P#(K0125) as shown in Figure B.



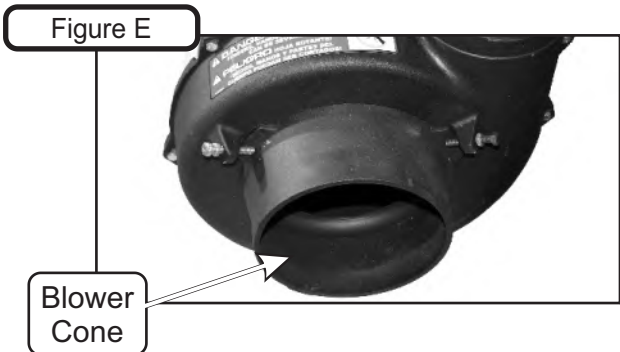
Now partially thread (1) bolt into each of the two threaded bosses located on the Blower Housing. Place 8" Blower Cone P#(E6009) so the two tabs line up with the bolts and tighten completely as shown in Figure C.



Once the (2) bolts are tight, tighten the Jam Nuts against the threaded boss as shown in Figure D.



Refer to Figure E for proper Blower Cone installation reference.

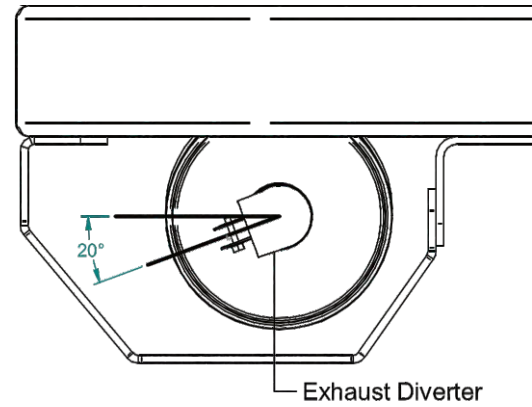
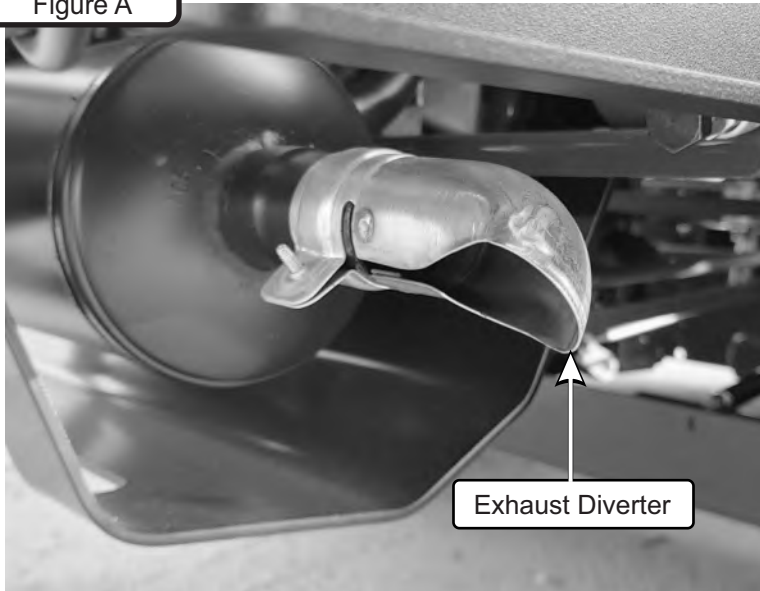


## Exhaust Diverter Installation

This Exhaust Diverter P#(J0150) is used to divert the mower's exhaust directly away from your Drive unit to prevent any damage that may occur. Position and install the Exhaust Diverter P#(J0150) onto the end of the exhaust of your mower, make sure the Exhaust Diverter is angled 20° down and away from the mower, see Figure A below.

Note: Some parts and part features have been hidden from view for visual clarity.

Figure A

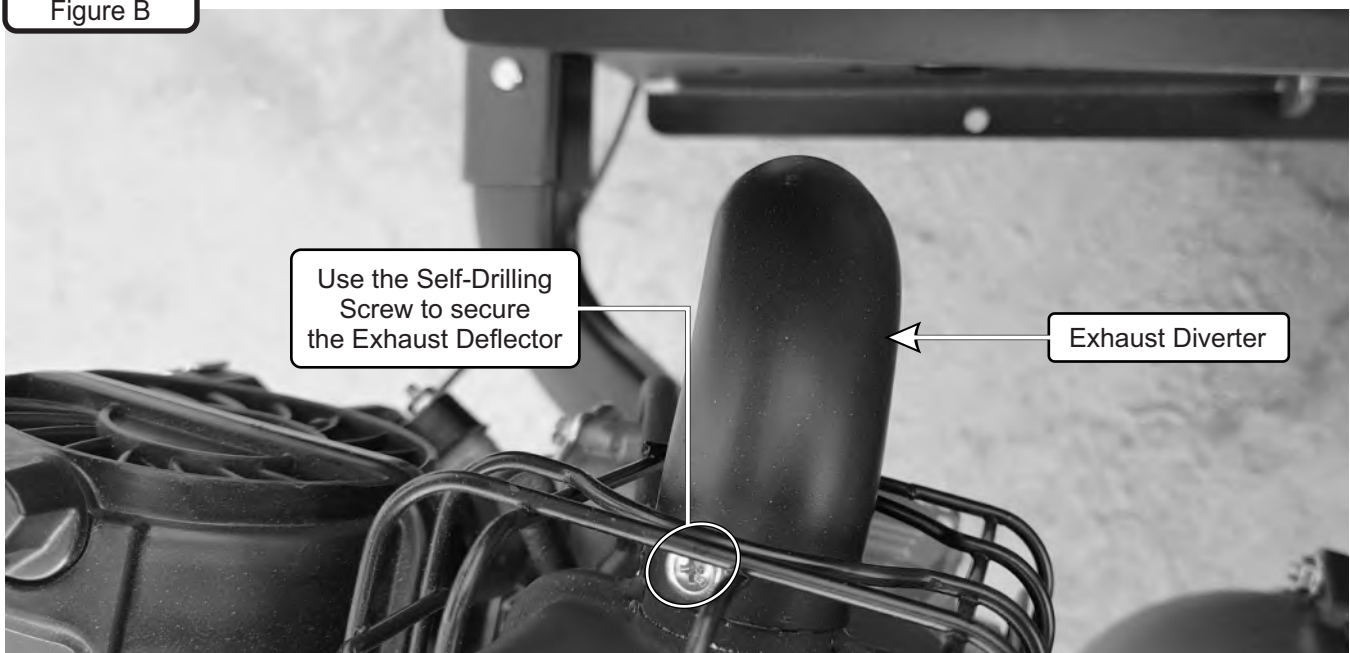


### Engine Drive

This Exhaust Diverter P#(J0251) is used to divert the exhaust directly away from the mower to prevent any damage that may occur. Position and install the Exhaust Deflector P#(J0251) onto the end of the exhaust of the Engine Drive Assembly, make sure the Exhaust Deflector is pointed downwards.

Secure the Exhaust Deflector onto the Exhaust by using (1) Self-Drilling Screw P#(K1504), see Figure B below.

Figure B



## Deck Baffle Installation

Your unit will need to install a Deck Baffle (Item #1) to prevent any build up of grass clippings or to prevent any discharge / blowout from the front of your Aluminum Boot.

With your mower deck lifted, position the Deck Baffle (Item #1) under the Deck with the side face of the baffle relatively flushed to the side of the deck.

Align the bolt holes of the Deck Baffle with the bolt holes on the deck and secure the Deck Baffle using (2) 3/8"-16 x 1" Carriage Bolts (Item #2.1), (2) 3/8"-16 Ny-Flange Lock Nuts (Item #2.2), (1) 5/16"-18 x 3/4" HHCS (Item #2.3), (1) 5/16" Flat Washer (Item #2.4), and (1) 5/16"-18 Flange Nut (Item #2.5). Refer to Figure A and Figure B.

The instructions above is also applicable for the installation of the 52" Deck Baffle Part#(B2249).

Note: Some parts and part features have been hidden form view for visual clarity.

Figure A

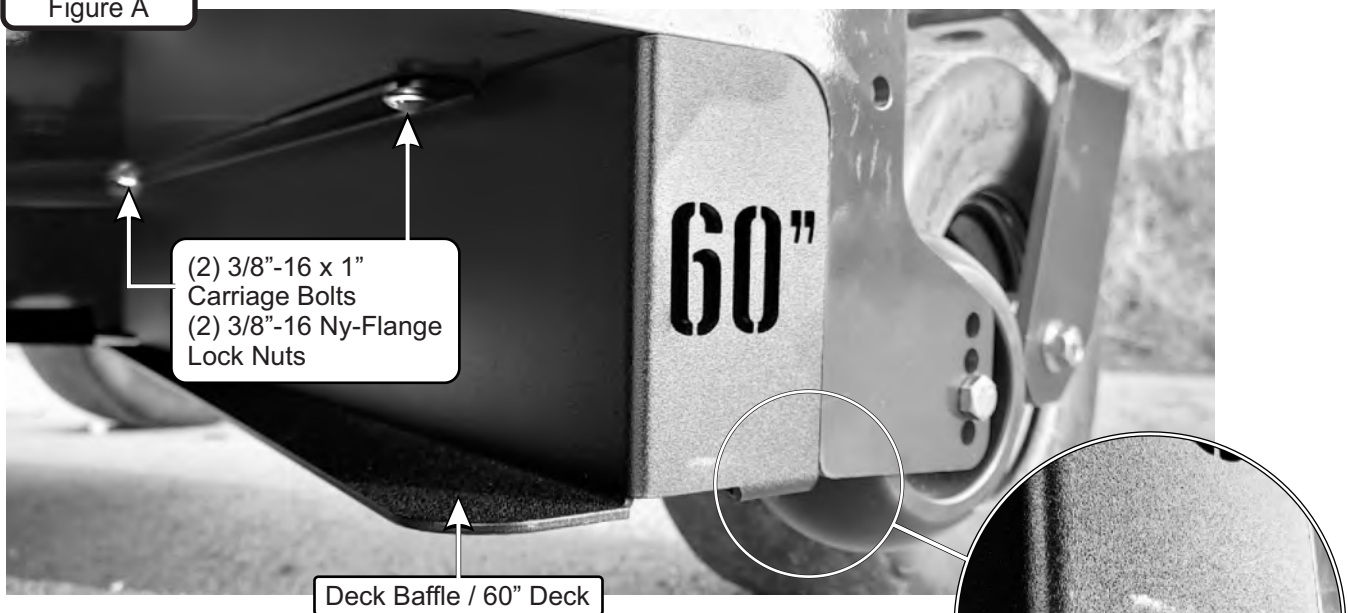
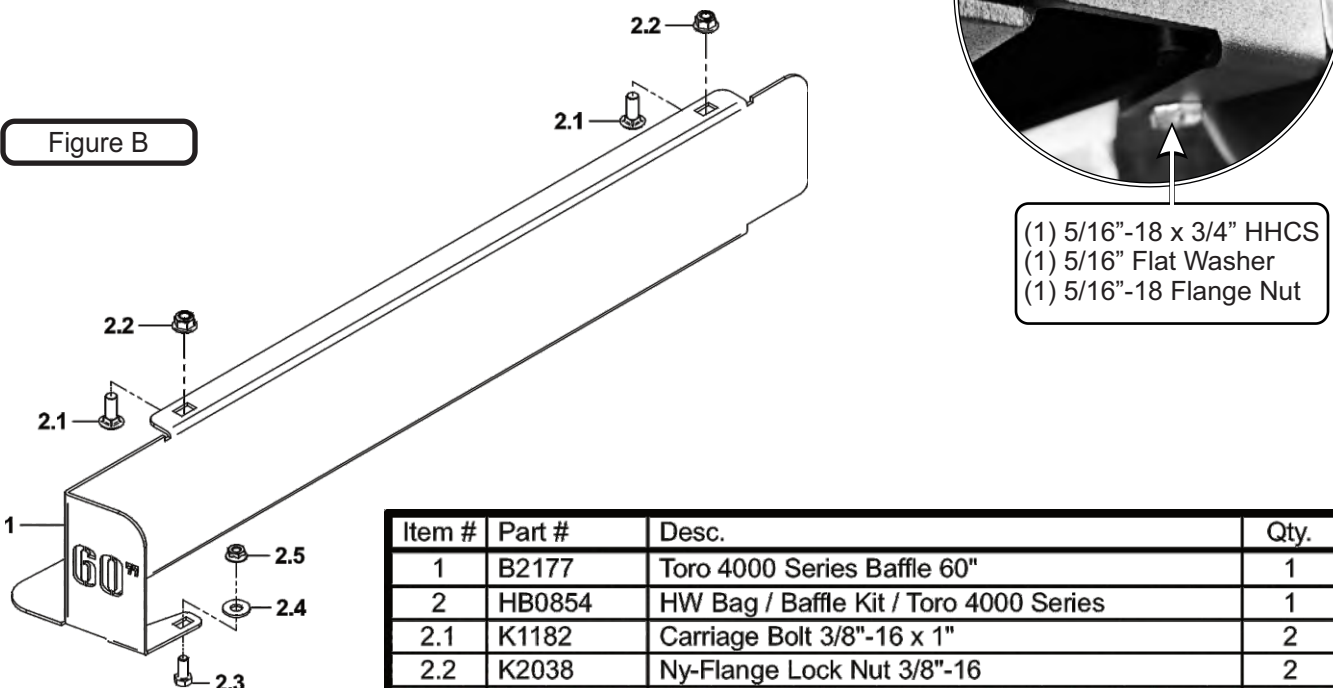


Figure B



Item #	Part #	Desc.	Qty.
1	B2177	Toro 4000 Series Baffle 60"	1
2	HB0854	HW Bag / Baffle Kit / Toro 4000 Series	1
2.1	K1182	Carriage Bolt 3/8"-16 x 1"	2
2.2	K2038	Ny-Flange Lock Nut 3/8"-16	2
2.3	K1153	HHCS 5/16"-18 x 3/4"	1
2.4	K0042	Flat Washer 5/16" / .875 OD x .380 ID x .075 T	1
2.5	K1178	Flange Nut 5/16"-18	1

## Boot Kit Installation

First, remove the mower's deck discharge chute deflector fasteners and set the discharge chute deflector aside. Then, secure the Boot Plate (Item #2) to the Aluminum Boot (Item #1) using (2) 3/8"-16 x 1" Carriage Bolts (Item #4.1) and (2) 3/8"-16 Ny-Flange Lock Nuts (Item #4.2), see Figure B. Leave the hardware loose until the boot plate has been attached to the mower deck.

Next, align the Boot Plate, discharge chute deflector and deck as shown in Figure A. Insert (1) Boot Rod (Item #3) through the Boot Plate, discharge chute deflector and deck mount tabs. Secure the Boot Rod using (1) Hair Pin Clip (Item #4.3). See Figure A and Figure B.

Finally, with the Carriage Bolts still loose, adjust the position of the boot so that there is no gap between the mower deck and the boot. Once adjusted, tighten all hardware at this time.

Figure A

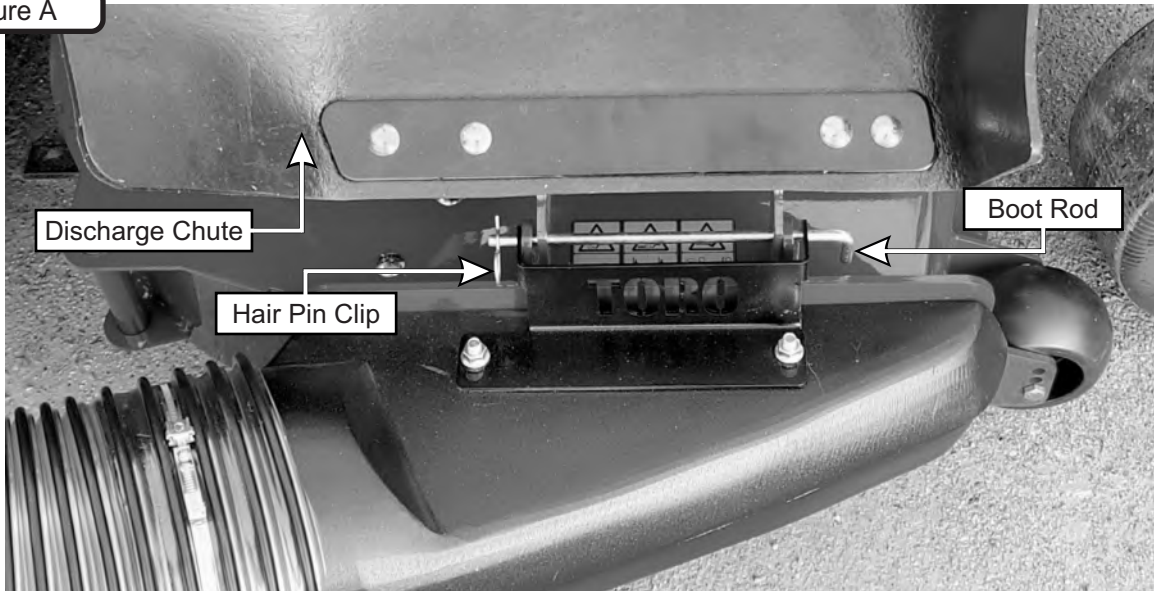
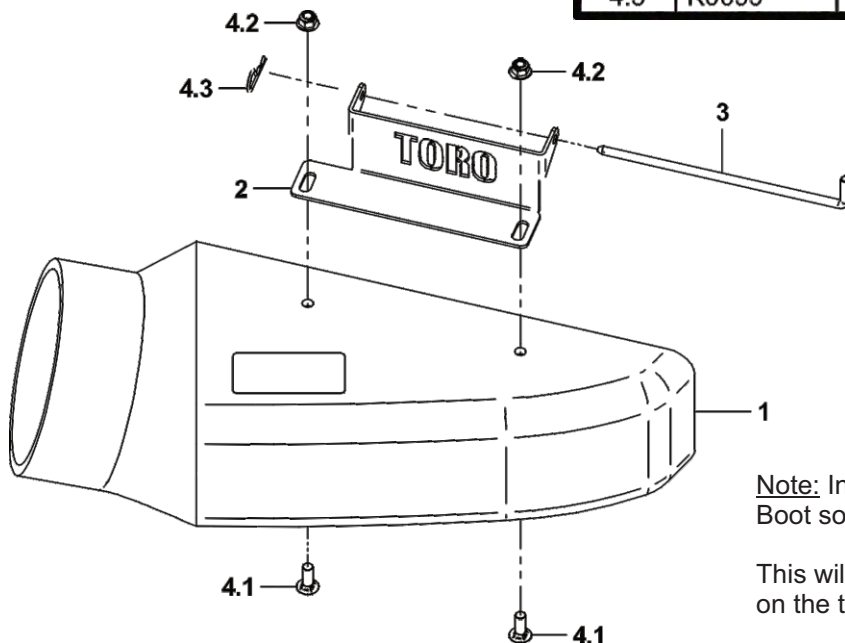


Figure B

Item #	Part #	Desc.	Qty.
1	E0032A	Modified E0032	1
2	B2198	Boot Plate / Toro 4000 Series	1
3	B0244	Boot Rod	1
4	HB0688	HW Bag / Boot Kit	1
4.1	K1182	Carriage Bolt 3/8"-16 x 1"	2
4.2	K2038	Ny-Flange Lock Nut 3/8"-16	2
4.3	K0099	Hair Pin Clip 3/32"	1



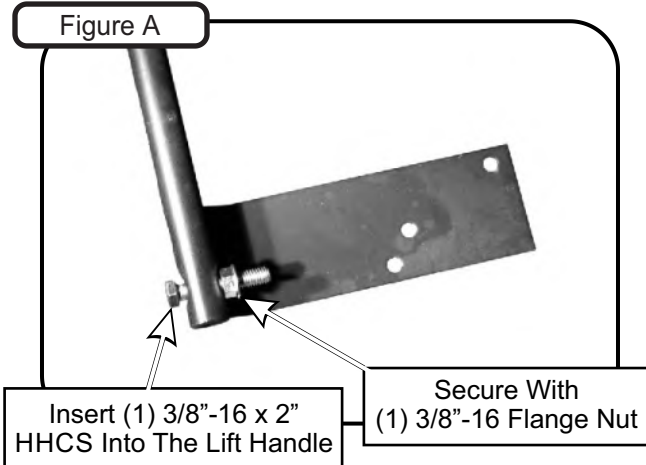
**Note:** Insert the Carriage Bolts from the inside of the Boot so the threads are on the top of the Boot.

This will prevent grass clippings from collecting on the threads.

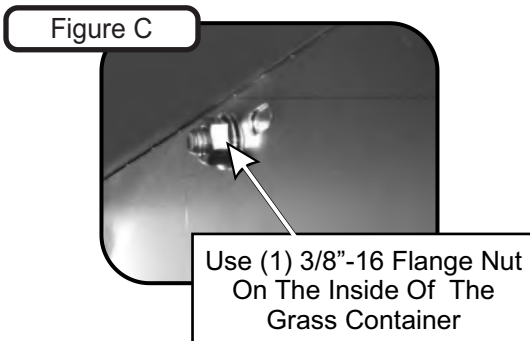
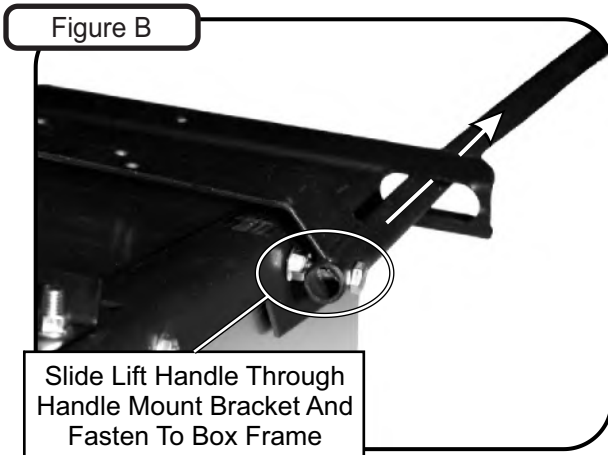


## Lift Handle Installation

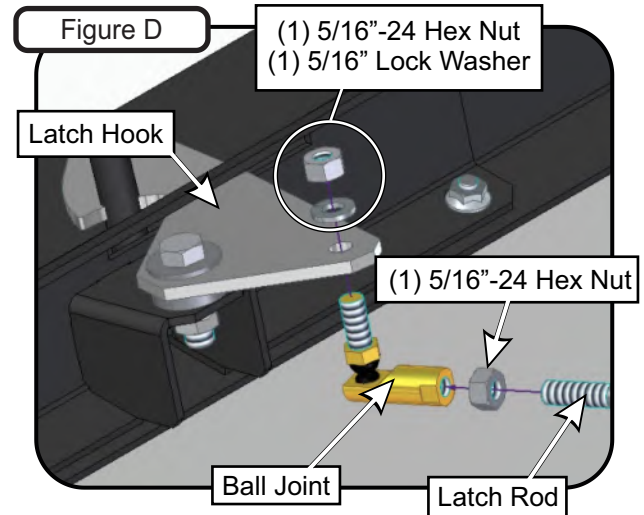
**NOTE:** Before continuing the Lift Handle installation, have someone assist you in turning the Box Assembly upside down. Insert (1) 3/8"-16 x 2" HHCS P#(K1208) into the Lift Handle P#(A0897), and secure with (1) 3/8"-16 Flange Nut P#(K1215). Thread the flange nut onto the bolt upside down, as shown in Figure A. Do not tighten the nut fully at this time.



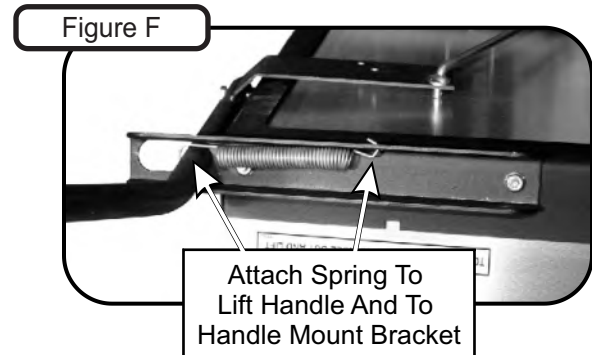
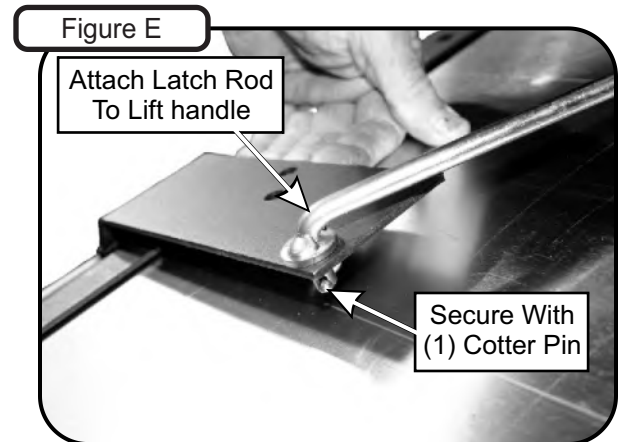
Slide the Lift Handle through the slot on the Handle Mount Bracket. Insert the Lift Handle into the Box Frame as shown in Figure B, and secure using (1) 3/8"-16 Flange Nut P#(K1215) on the inside of the Box as shown in Figure C. Now test the movement of the handle. It should have full-range of movement in the slot. If the handle does not have full-range of movement, adjust the 3/8"-16 Flange Nut from step A. Once achieved, tighten the fasteners.



Fasten the Ball Joint P#(K1442) to the end of the Latch Rod P#(A2107). Thread (1) 5/16"-24 Hex Nut P#(K1444) all the way down onto the Latch Rod then tighten the Ball Joint to approximately half-way down the threads on the Latch Rod. Readjust the Hex Nut so it'll be right under the Ball Joint. Attach the Ball Joint to the Latch Hook as shown in Figure D, using (1) 5/16"-24 Hex Nut P#(K1444) and (1) 5/16" Lock Washer P#(K0043).



Attach the other end of the Latch Rod to the Lift Handle, as shown in Figure E. Attach one end of the Spring P#(J0176) to the Lift Handle and the other end of the Spring to the Handle Mount Bracket as shown in Figure F. Adjust the Ball Joint up or down on the Latch Rod threads until the Latch Hook closes completely. After adjusting the Latch Hook, secure the Latch Rod to the Lift Handle using (1) Cotter Pin P#(K0094).



## Aluminum Box Assembly Installation

**NOTE:** It is recommended that two extra people assist in mounting the Box Assembly. Two can lower the Box onto the frame while the third person inserts the Pivot Pins P#(K0172) through the holes. Insert the Pins from the outside to the inside. Secure with (1) 5/8" Washer P#(K0058) and (1) 5/32" x 2-5/8" Hair Pin Clip P#(K0088) per Pivot Pin (Figure B). Reattach the bottom ends of the door opening linkages to the Main Frame by using (1) Rue-Ring Cotter Pin P#(K1437) per side. To test the functionality of the dump mechanism, pull the Lift Handle away from the unit, and lift upward. The Door of the Box Assembly should open and the Box should pivot clockwise towards the ground.

Figure A

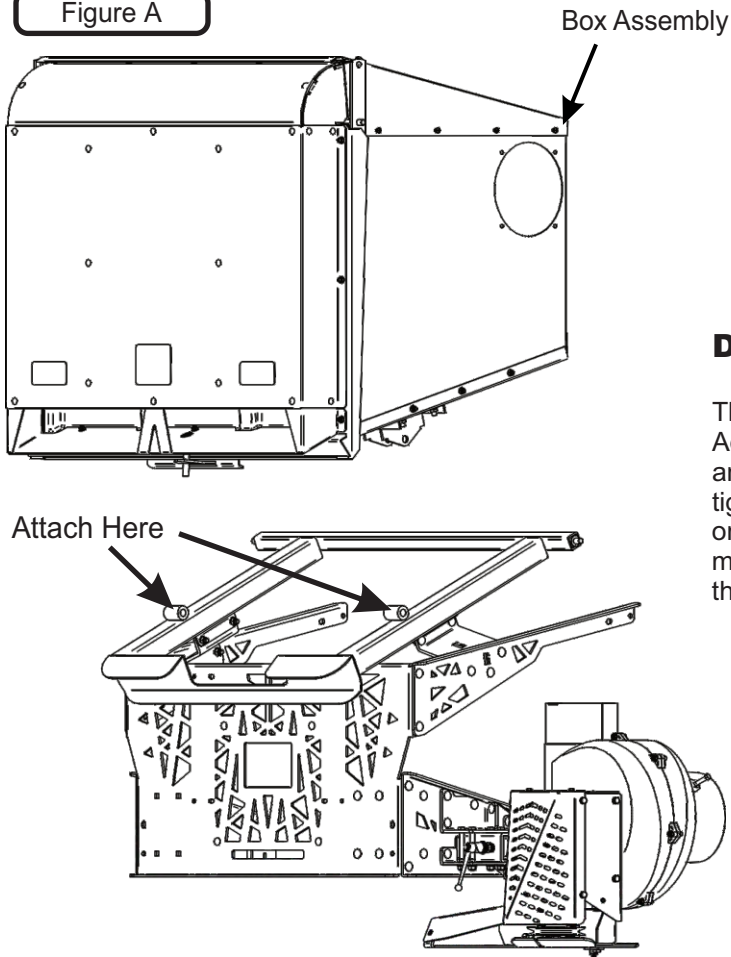
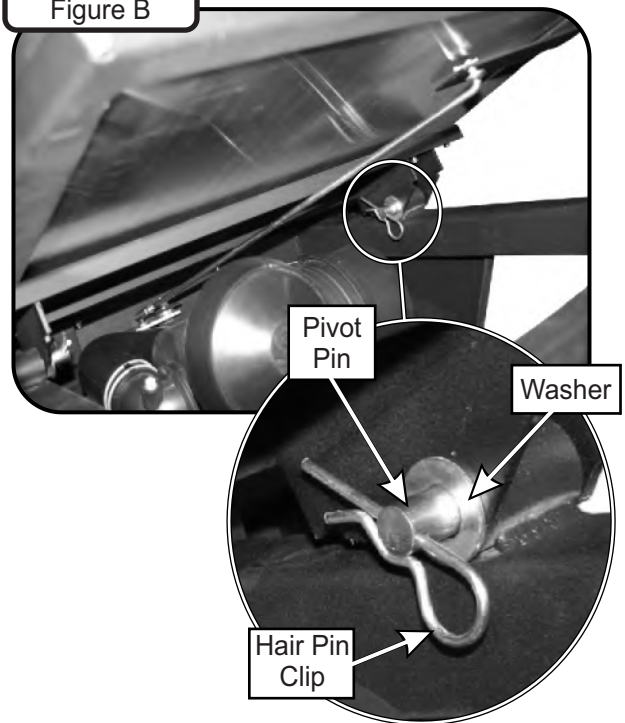


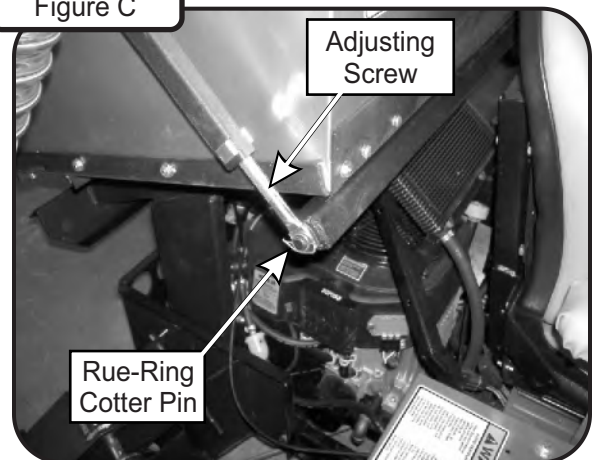
Figure B



## Dump Mechanism Adjustment

The mechanism may be adjusted in three places, at the Adjusting Screw P#(K1435), at the Latch Hook Pivot Bolt and the linkage Ball Joint. To change the door closure tightness, thread the Adjusting Screw (Figure C) in or out or by adjusting the Latch Hook Pivot Bolt within its' mounting slot. To adjust the Latch Hook closure angle, thread the Linkage Ball Joint in or out.

Figure C



## Inlet, Inlet Ring & Debris Deflector Installation

Open box door. From inside box, slide Inlet (Item #3) halfway into inlet hole (See Figure A). Take each half of the Inlet Ring (Item #1) and attach around matching groove in Inlet (Item #3). Slide Inlet (Item #3) & Inlet Ring (Item #1) against inlet hole and align four holes. Fasten Inlet Ring (Item #1) bottom holes using (2) 5/16" IT Tooth Lock Washers (Item #4) & (2) 5/16"-18 x 1/2" HHCS (Item #5) (See Figure B). Fasten Inlet Ring (Item #1) top holes using (2) 5/16" IT Tooth Lock Washers (Item #4) & (2) 5/16"-18 x 1-1/4" HHCS (Item #6). Slide Debris Deflector (Item #2) over inside top bolt threads (Item #5). Fasten Debris Deflector (Item #3) using (2) 5/16"-18 Ny-Flange Lock Nuts (Item #7). Final assembly should resemble Figure C.

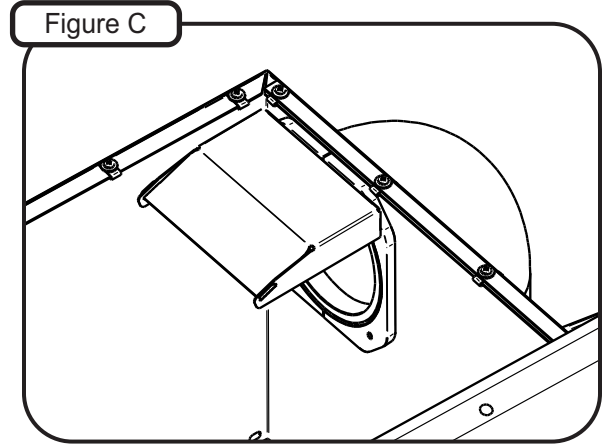
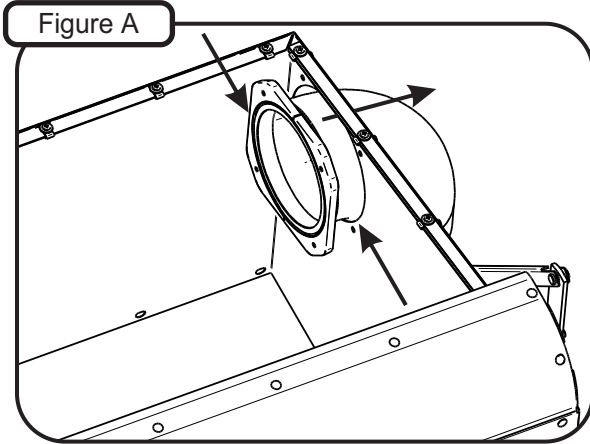
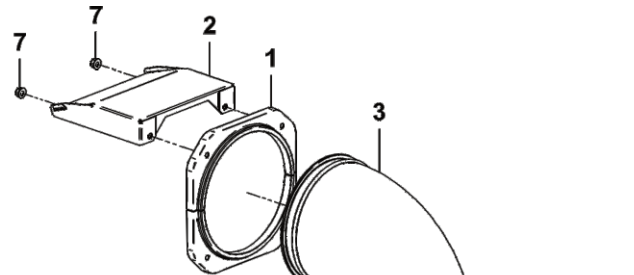
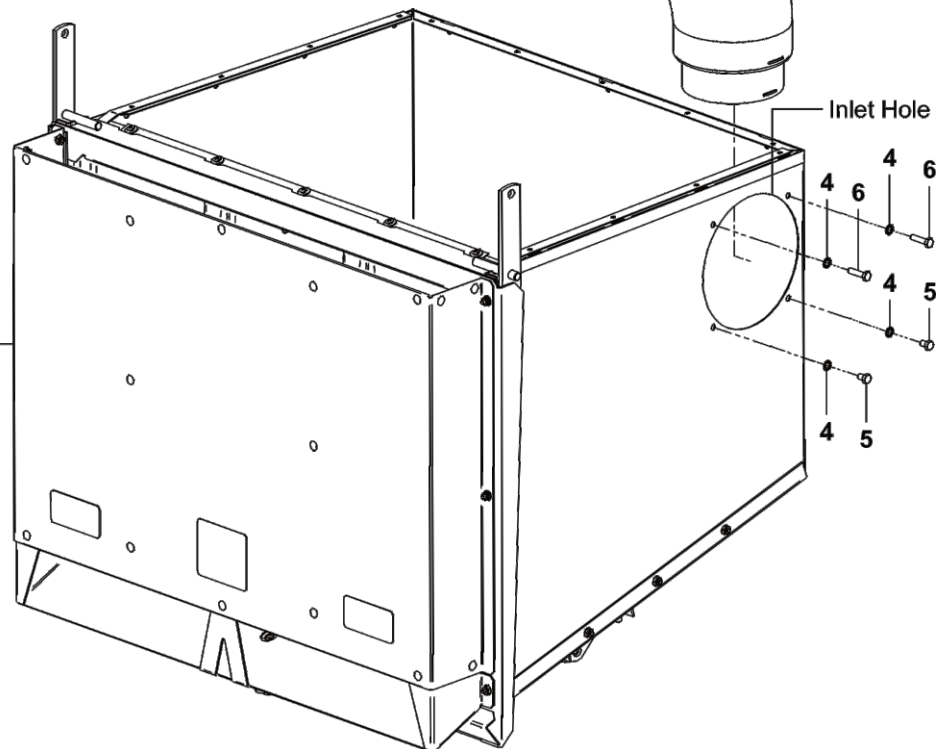


Figure B

Item #	Part #	Desc.	Qty.
1	C0074	Inlet Ring	1
2	C0088	Debris Deflector	1
3	V0025	Universal Inlet / 6" & 7"	1
4	K0044	I/T Tooth Lock Washer 5/16"	4
5	K1152	HHCS 5/16"-18 x 1/2"	2
6	K1156	5/16"-18 x 1-1/4" HHCS	2
7	K2516	Ny-Flange Lock Nut 5/16"-18	2



Open Box Door  
to Install Inlet,  
Inlet Ring &  
Debris Deflector



**Note:** Box Top & Screen Removed  
in Figure for visual clarity.

## Length Of Hose Adjustment

The hoses in the following steps must be cut to fit your machine. Do not cut the hoses until you have tried to fit them on your machine. Remember that the hoses need to be long enough to allow for the opening and closing of the collection system as well as allowing ample clamping surface between each component.

## Upper Hose Installation

Slide a Hose Clamp P#(J0060) over one end of the 6" Upper Hose. Secure this end of the 6" Upper Hose to the Blower Outlet. See Figure below for details. Secure opposite end of the 6" Upper Hose to the Inlet. Make sure both ends are securely fastened by tightening the Hose Clamp and rotating the Inlet Snap Fastener towards the hose to lock in place.

## Lower Hose To Blower Cone Installation

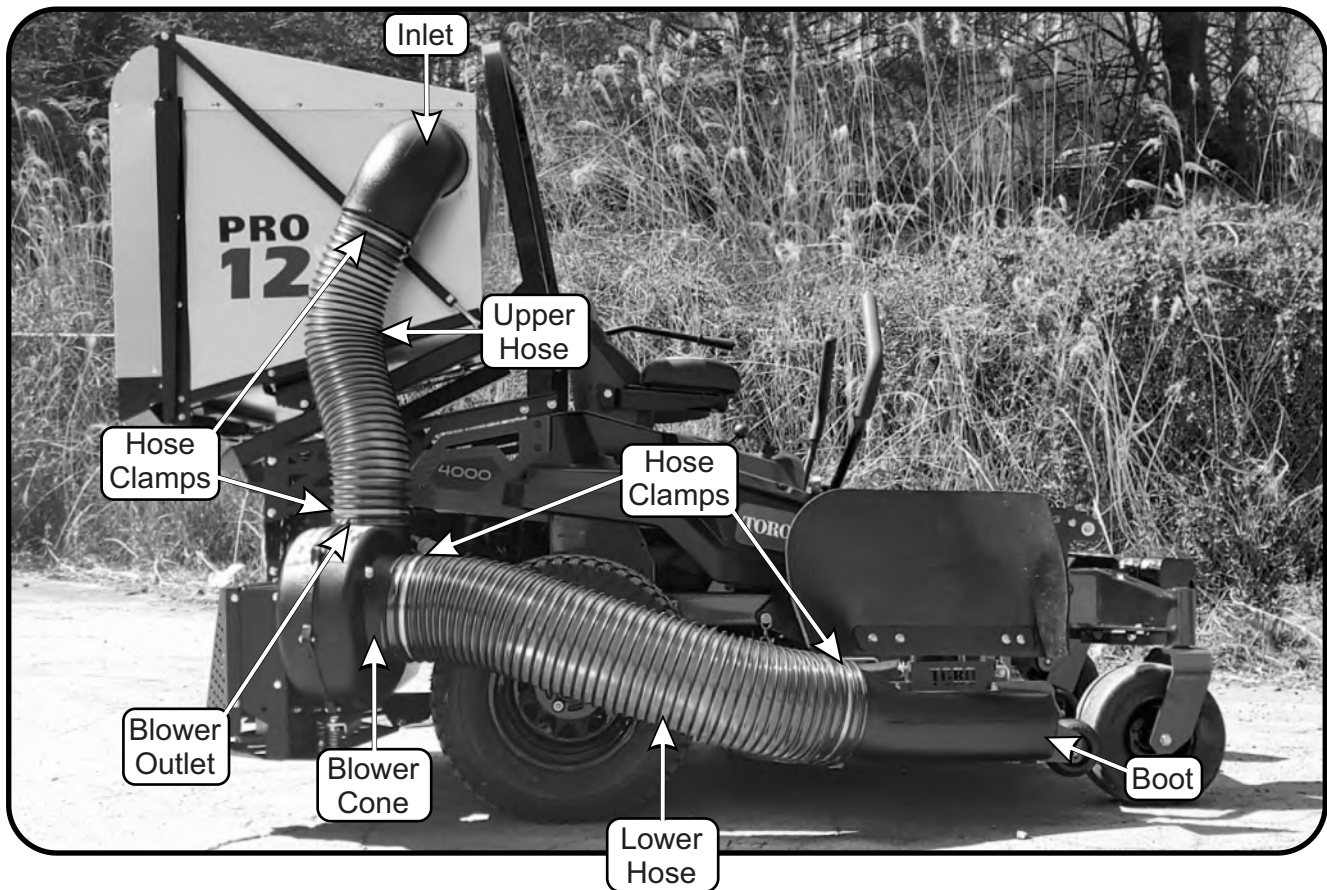
Slide a Hose Clamp P#(J0080) over both ends of the Lower Hose. Secure one end of the Lower Hose to the Blower Cone and fasten by tightening the Hose Clamp.

## Lower Hose To Boot Installation

Take the unattached end of the Lower Hose and secure it to the circular end of the Boot and fasten by tightening the Hose Clamp.

Tip: Before securing Hose Clamp fully, rotate Lower Hose counter-clockwise (away from yourself) approximately 1" to aid in retaining Boot to mower deck.

### Engine Driven Unit Shown Below



## Wire Harness Installation

PTO-X

First, install the PTO Rocker Switch (Item #2) by positioning it over the Switch Mount Plate (Item #1) and firmly pressing the Rocker Switch down until it is seated in place (Refer to Figure A). Next, connect the Wire Harness' (2) Female Switch Disconnects (Refer to Figure A) to the PTO Rocker Switch. See Figure E on Page 28 for complete Wiring Diagram.

Then, position the PTO Switch Mount onto the panel Right of the Operator's seat. Refer to Figure B. Note the locations of the (2) bolt holes of the Switch Plate and the (2) bolt holes on the panel Right of the Operator's seat.

Finally, secure the PTO Switch Mount by using (2) 5/16"-18 x 3/4" HHCS P#(K1153) and (2) 5/16"-18 Ny-Flange Lock Nuts P#(K2516). See Figure B.

Figure A



(2) Female Switch Disconnects  
to PTO Rocker Switch

Item #	Part #	Desc.	Qty.
1	B2040	Switch Mount/ Toro	1
2	P0293	PTO Engagement Rocker Switch	1

 **WARNING**

**To Prevent Serious Injury-  
Proper Installation Of Safety Interlock Harness  
Is Mandatory. Please Check That All Interlock  
Points Work Correctly Once Installed.**

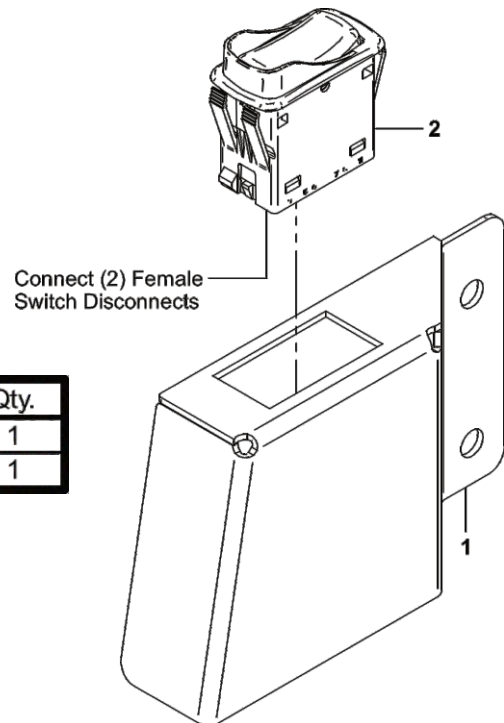
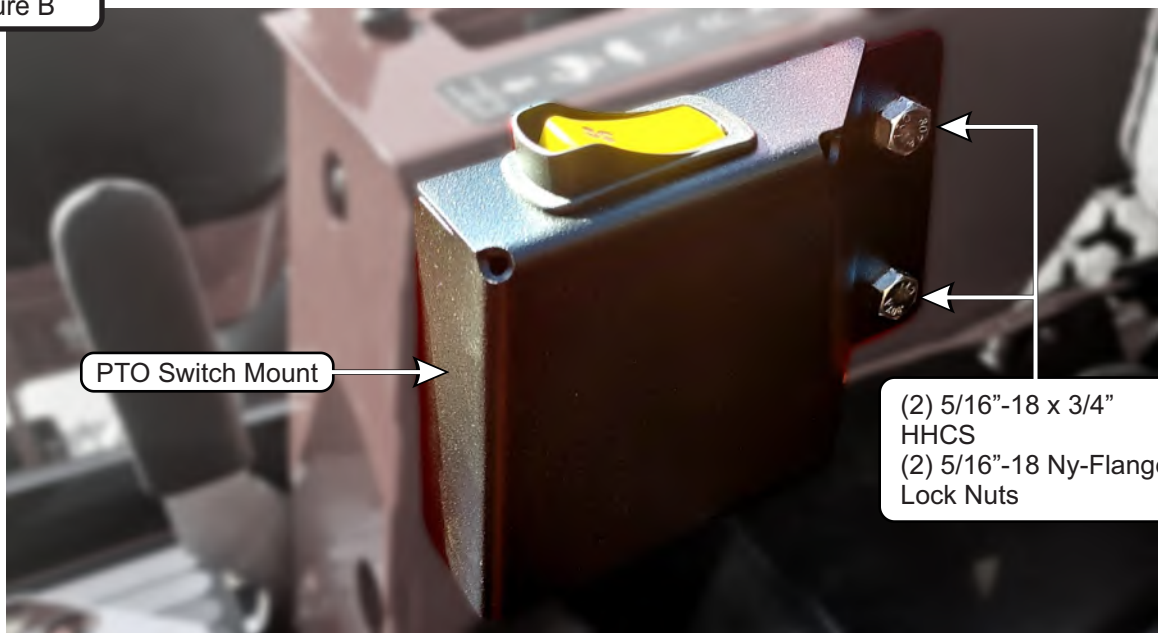


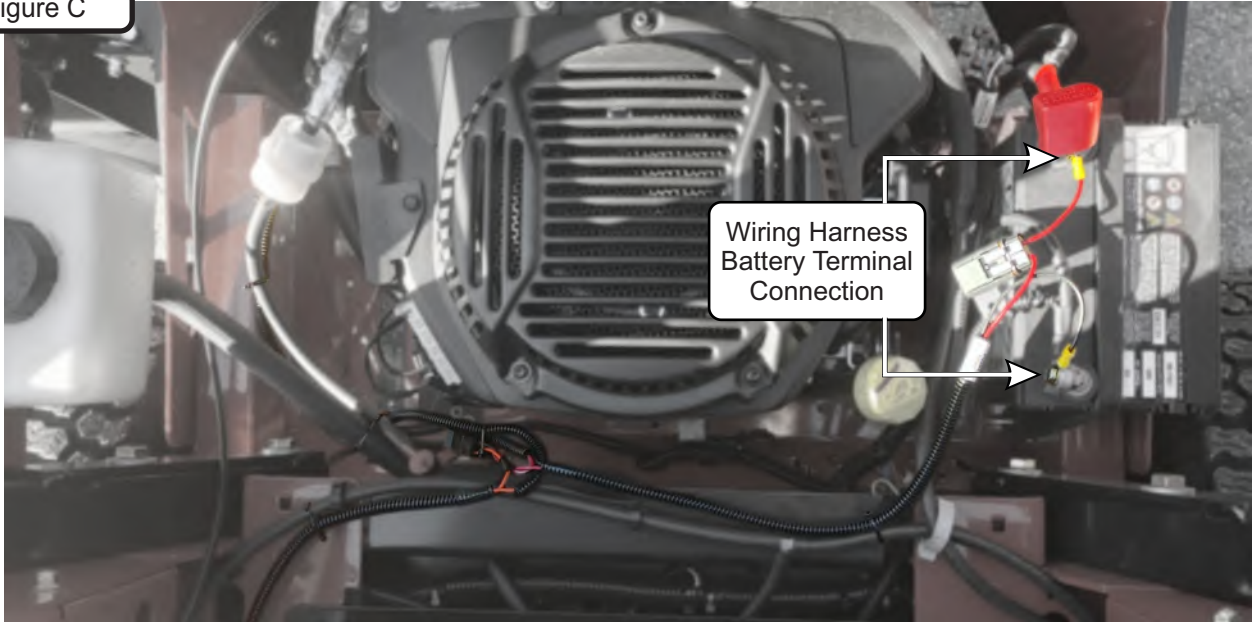
Figure B



(2) 5/16"-18 x 3/4"  
HHCS  
(2) 5/16"-18 Ny-Flange  
Lock Nuts

Next, route the Negative Lead (-) and the Positive Lead (+) of the Wire Harness P#(P0298) (Refer to Figure C) to the negative & positive terminal of the mower's battery. Then, disconnect the mower's clutch connector and interconnect with the Wire Harness' Clutch Connection Jumper. Be sure to identify and pick the correct Jumper depending on your mower's clutch connection type. Refer to the Wiring Diagram on Page 28 for the Connection Jumper Types.

Figure C



Positive Lead (+) to Positive Terminal (+)



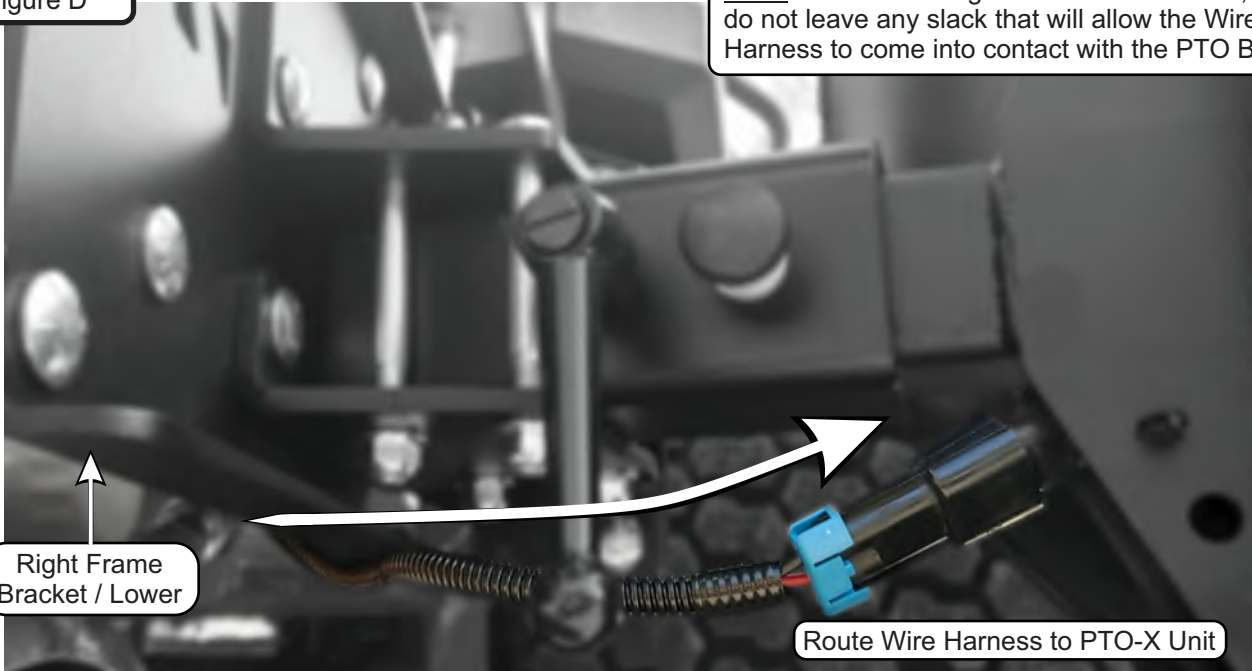
Negative Lead (-) to Negative Terminal (-)

Finally, route the Wire Harness back towards the rear of the mower positioning the Wire Harness under the Right Frame Bracket / Lower. Then connect the Wire Harness to the PTO Unit. Refer to Figure D.

**Note:** It is recommended to secure the Wire Harness to the mower by using the (8) included Cable Ties P#(J0245) once you have the Wire Harness installed. Be sure the Wire Harness is routed so that it does not obstruct the seat as it is being lowered down or any part of the mower that may damage the Harness.

Figure D

**Note:** To avoid damage to the Wire Harness, do not leave any slack that will allow the Wire Harness to come into contact with the PTO Belt

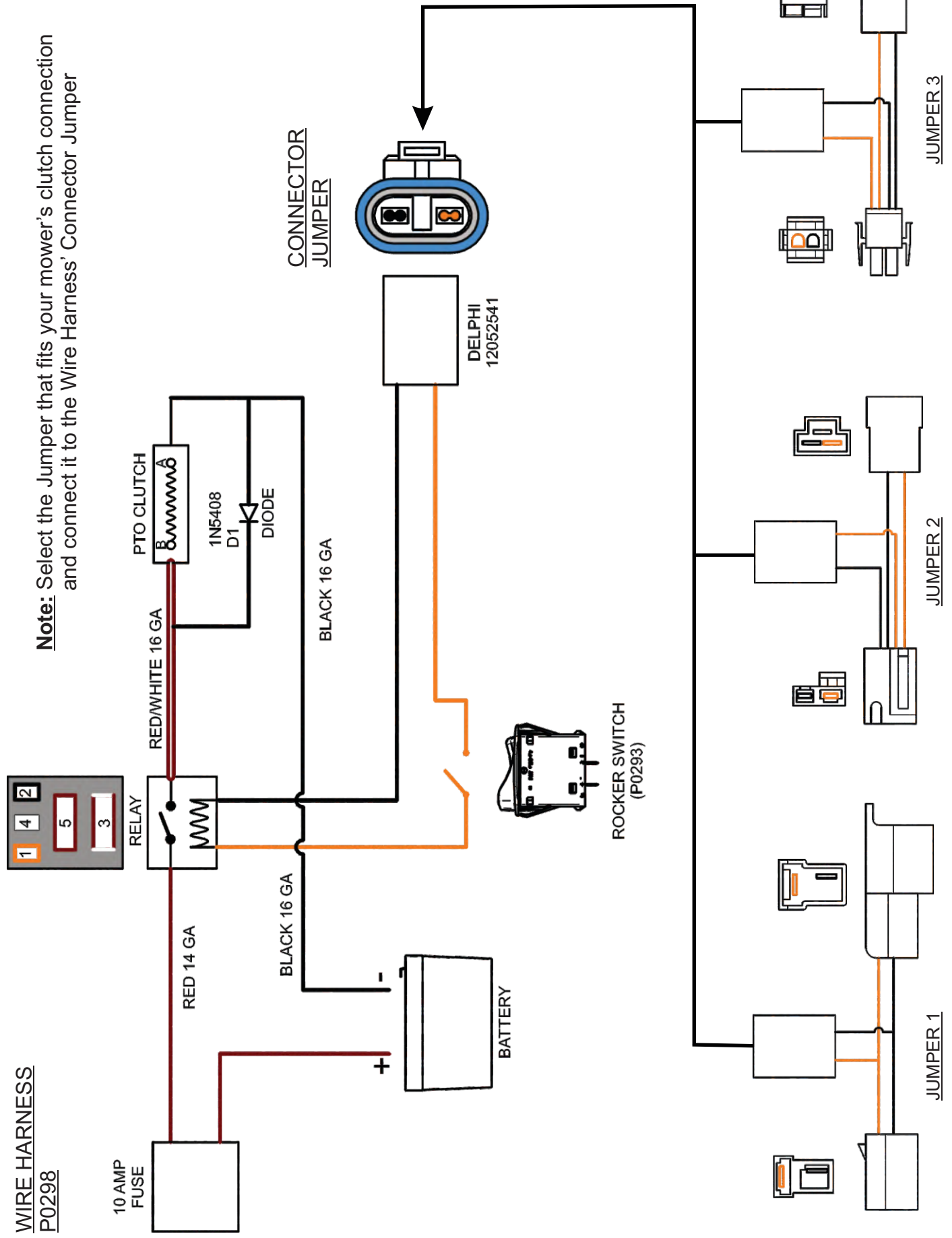


# Wire Harness Installation (Continued)

PTO-X

Figure E

**Note:** Select the Jumper that fits your mower's clutch connection and connect it to the Wire Harness' Connector Jumper



**WIRE HARNESS**  
P0298

10 AMP FUSE

RED 14 GA

RED/WHITE 16 GA

PTO CLUTCH

1N5408 D1 DIODE

BLACK 16 GA

BLACK 16 GA

BATTERY

DELPHI 12052541

ROCKER SWITCH (P0293)

CONNECTOR JUMPER

JUMPER 1

JUMPER 2

JUMPER 3

# Throttle Kit Installation

Engine Drive

## Engine Driven Unit Instructions

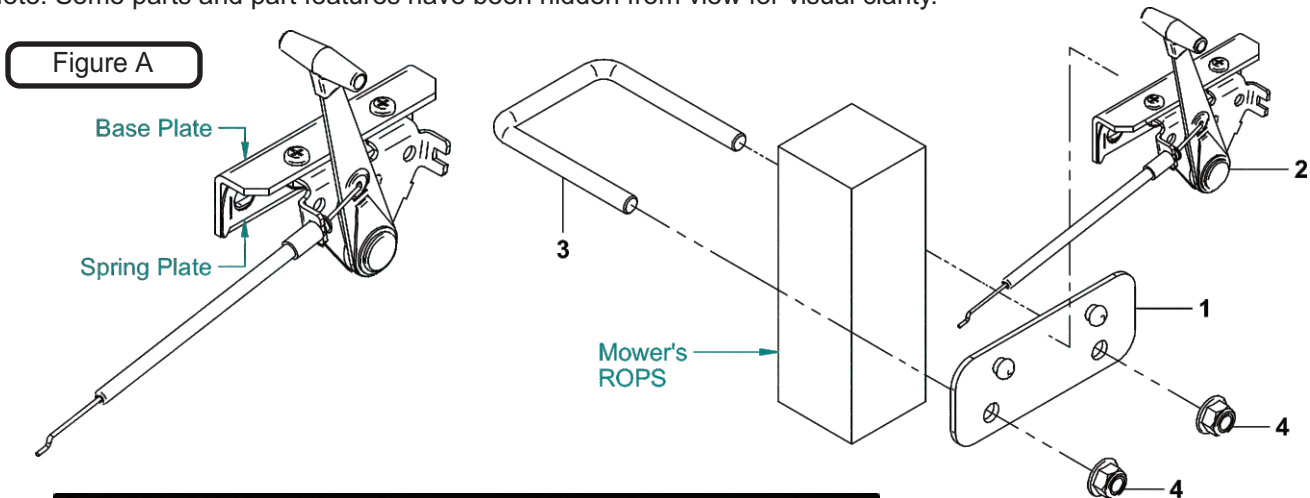
The Throttle Kit is installed on the right side ROPS above of the Right Frame Bracket / Upper, see Figure B.

Place the 3/8"-16 U-Bolt (Item #3) onto the right side ROPS with the threads facing out away from the side of the mower. Next slide on the Throttle Mount Plate Assembly (Item #1) with the rivets also facing outward away from the side of the mower. Secure the Throttle Mount Plate Assy to the ROPS by using (2) 3/8"-16 Ny-Flange Lock Nuts (Item #4). Refer to Figure A.

With the Throttle Cable Kit facing back towards the Mower's rear, place the Throttle Base Plate over the rivets, slide the Throttle Cable Kit to the right, moving the smaller end of the slot over the rivets. When positioned correctly, the Throttle Spring Plate will snap into place, see Figure A.

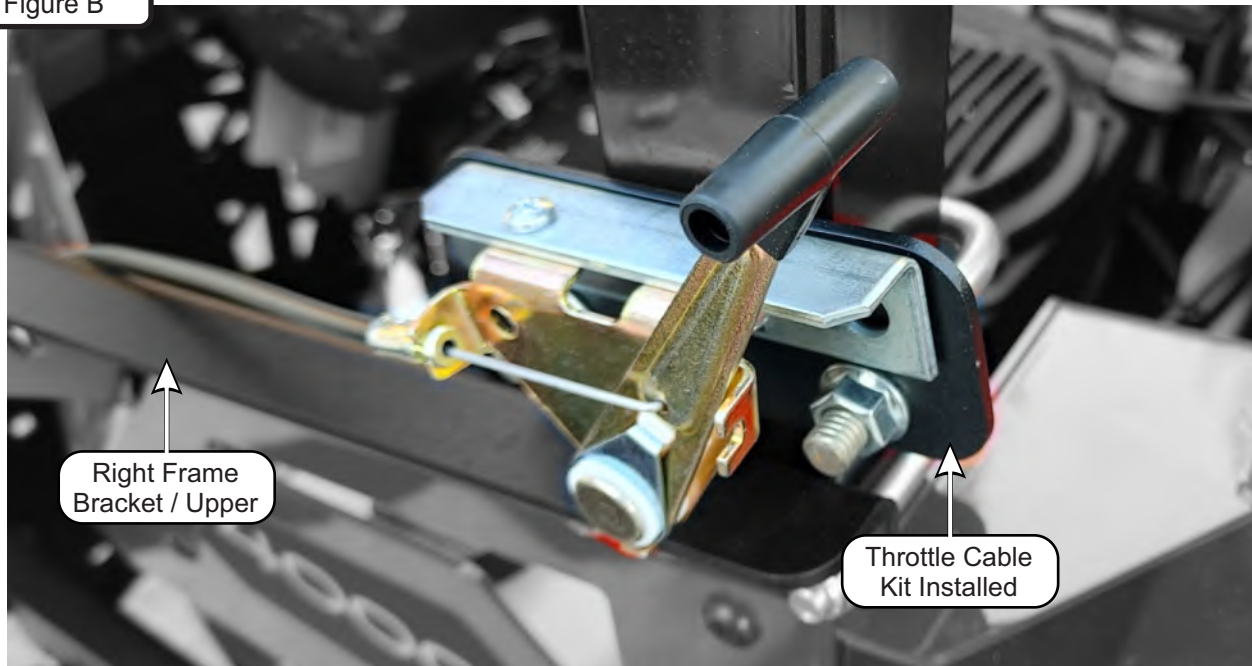
To remove the Throttle Cable Kit, lift the Throttle Spring Plate and slide the Throttle Kit to the left.

Note: Some parts and part features have been hidden from view for visual clarity.



Item #	Part #	Desc.	Qty.
1	A0666	THROTTLE MNT. PL. ASSY.	1
2	A0060	70" THROTTLE CABLE KIT	1
3	K0136	U-Bolt / 3/8"-16 x 2.562" x 3.50"	1
4	K2038	Ny-Flange Lock Nut 3/8"-16	2

Figure B





## Throttle Kit Installation (Continued)

Engine Drive

With your Throttle Kit installed, you'll need to route the cable of the Throttle Kit back towards the rear of the Mower. Refer to Figure C below.

Figure C

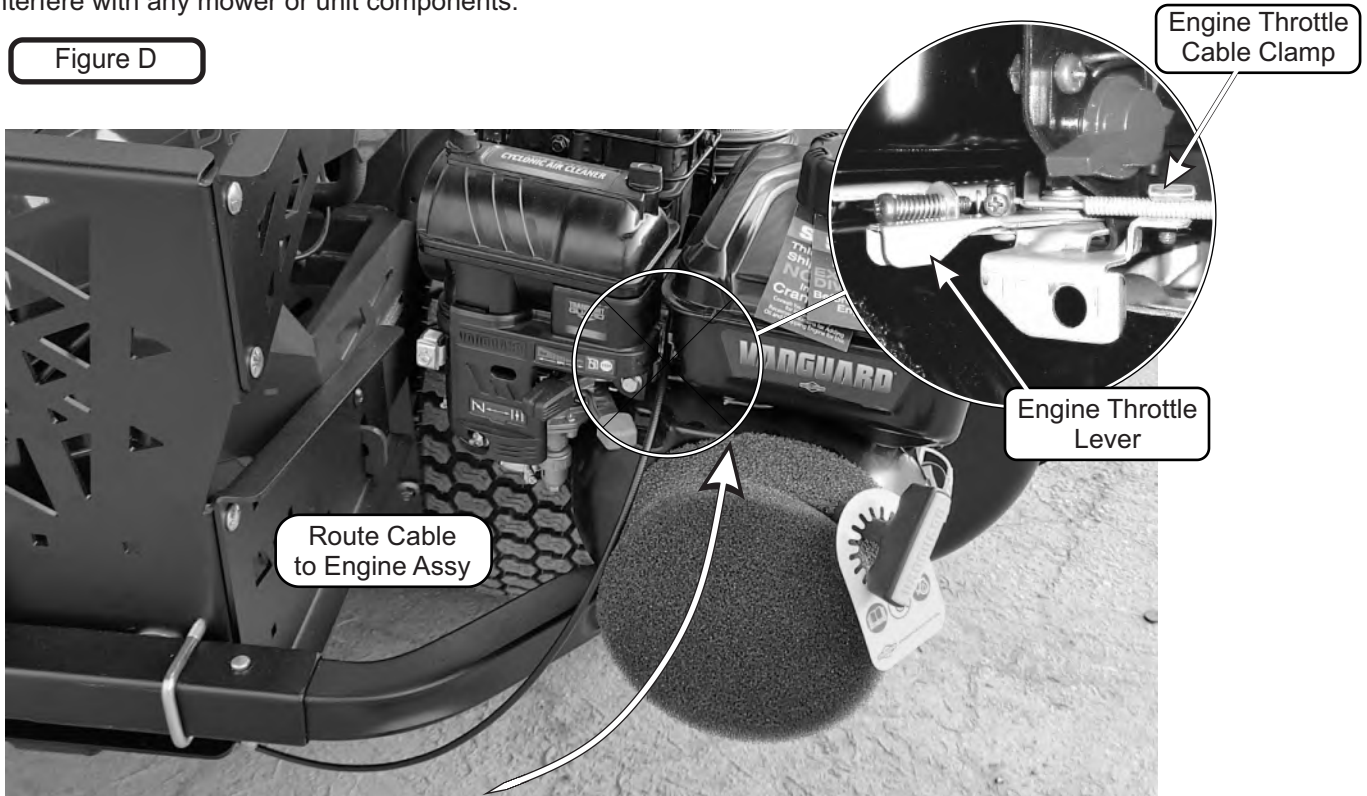


Next, bring the Cable out from under the Rear Frame Bracket & Engine Mount Arm up to the Engine/Blower/Blade Assembly. See Figure D.

Finally, place the Throttle control lever into the "STOP" position. Rotate the Engine's throttle lever to the "STOP" position. Thread the wire end of the Throttle Cable into the Engine's throttle lever eyelet and tighten the screw. Fasten the throttle cable sleeve to the clamp on the Engine throttle. See Figure D.

Rotate the throttle control lever into the "fast" position to check for proper installation. Make sure the Cable does not interfere with any mower or unit components.

Figure D



## Impeller Blade Removal/Replacement

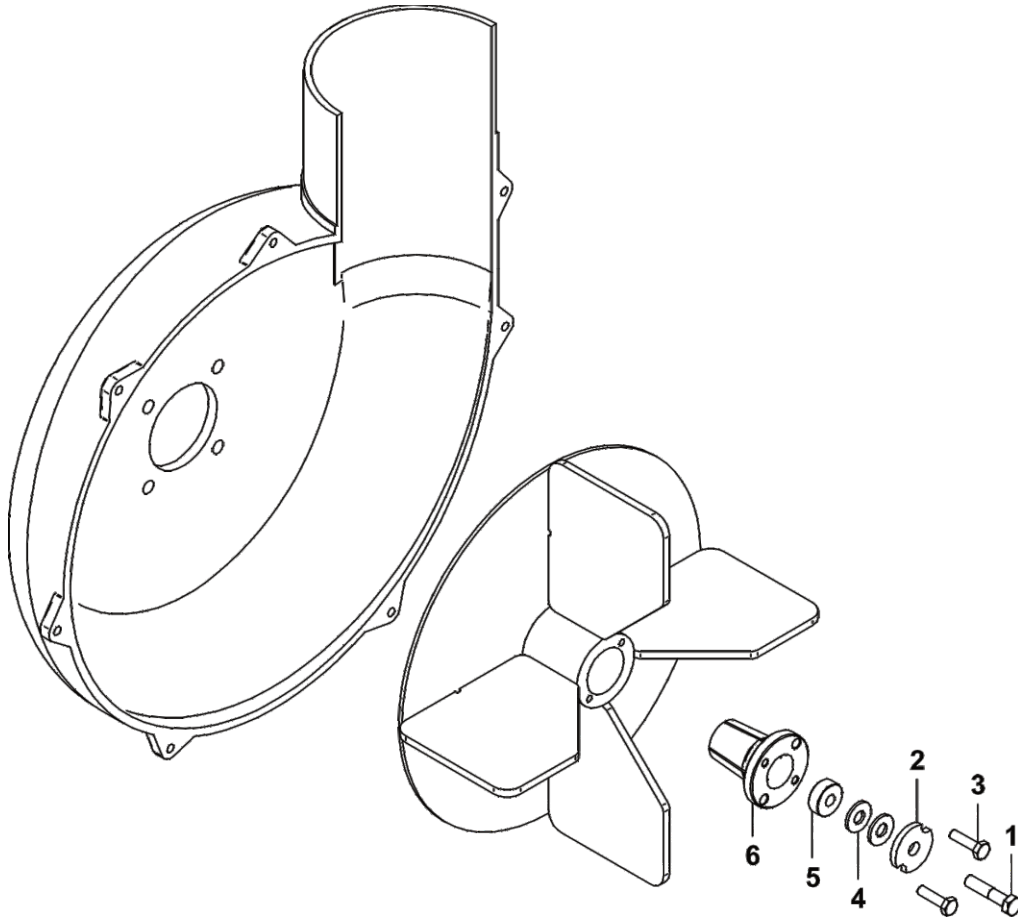
**To Remove:** First, remove the 5/16"-24 x 1-1/2" HHCS P#(K1465) (#1), Double Indented Washer P#(K0284) (#2), (2) 5/16" Flat Wahers P#(K0042) (#4) and Spacer Bushing P#(S0159) (#5) from the Taper-Lock Bushing P#(S0157) (#6).

Next, remove the (2) 1/4"-20 x 1" HHCS (#3) and place them into the threaded holes of the Taper-Lock Bushing (#6). Gradually thread each bolt evenly into the Taper-Lock Bushing forcing the blade to break-away from the Taper-Lock Bushing. If the Impeller will not move, carefully hit the base of the Impeller, between each vein, with a hammer, then try again.

**To Replace:** First, place the Impeller Blade over the engine shaft. Slide the Taper-Lock Bushing (#6) onto the engine shaft and into the Impeller Blade, aligning the **non-threaded** holes of the Taper-Lock Bushing to the threaded holes of the Impeller Blade.

Then, fasten the Impeller Blade by using (2) 1/4"-20 x 1" HHCS (#3), (1) Spacer Bushing (#5), (1) Double Indented Washer (#2), and (1) 5/16"-24 x 1-1/2" HHCS (#1). Torque bolts to their proper specifications as listed in the Torque Chart on the back of this Manual.

Finally, rotate the Impeller Blade to ensure that the blade is clear of contact on all sides of the Blower Housing. If there is interference, remove the Taper-Lock Bushing, reposition the Impeller Blade further from the Blower Housing, re-tighten the hardware, and then check for clearance.



Item #	Part #	Desc.	Qty.
1	K1465	HHCS 5/16"-24 x 1-1/2" GR8	1
2	K0284	Double Indented Washer 3/8" / 1.375 OD x .380 ID x .179 T	1
3	K1225	HHCS 1/4"-20 X 1" GR8	2
4	K0042	Flat Washer 5/16" / .875 OD x .380 ID x .075 T	2
5	S0159	Spacer Bushing .938 OD x .325 ID x .375 T	1
6	S0157	Taperlock Bushing 7/8"	1

## Weight Kit Installation

Position the Weight Bracket Weldment (P#A2370) under and center of both the Casters of the Mower as seen in Figure A. Align the mounting slots of the Weight Bracket Weldment to the holes of both the casters.

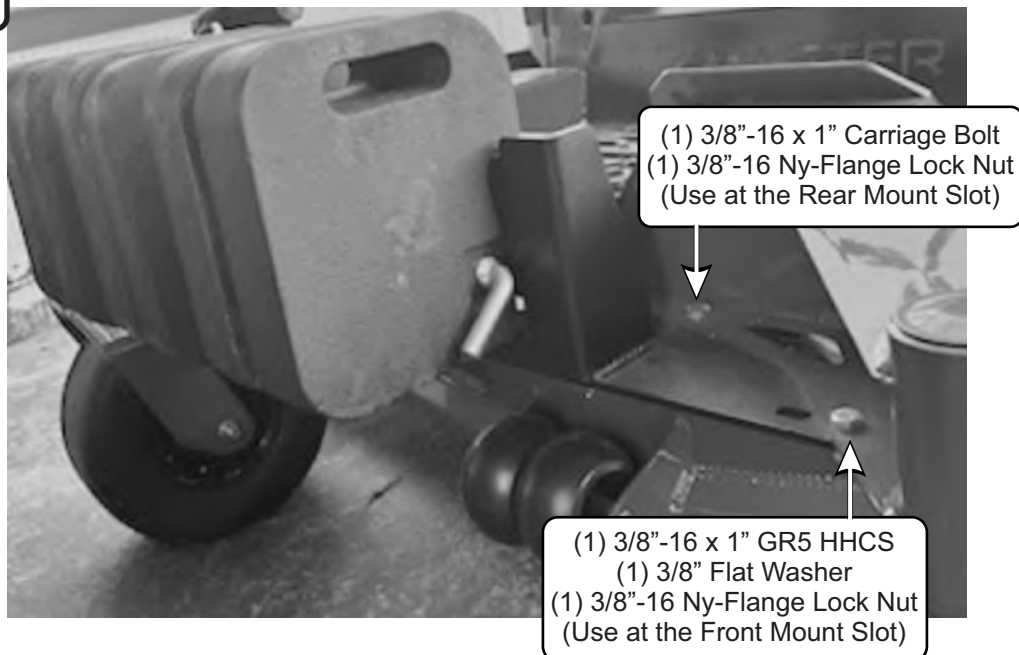
Fasten the Right Side of the Weight Bracket Weldment to the Right Side Caster, relatively loose, by using (1) 3/8"-16 x 1" GR5 HHCS, (1) 3/8" Flat Washer and (1) 3/8"-16 Ny-Flange Lock Nut in the Front Mounting Slot. Then use (1) 3/8"-16 x 1" Carriage Bolt and (1) 3/8"-16 Ny-Flange Lock Nut in the Rear Mounting Slot. See Figure B.

Repeat the process to mount the Left Side of the Weight Bracket Weldment. Once both sides have been mounted, tighten all hardware to fully secure the Weight Bracket Weldment.

Figure A



Figure B



## Weight Kit Installation (Cont.)

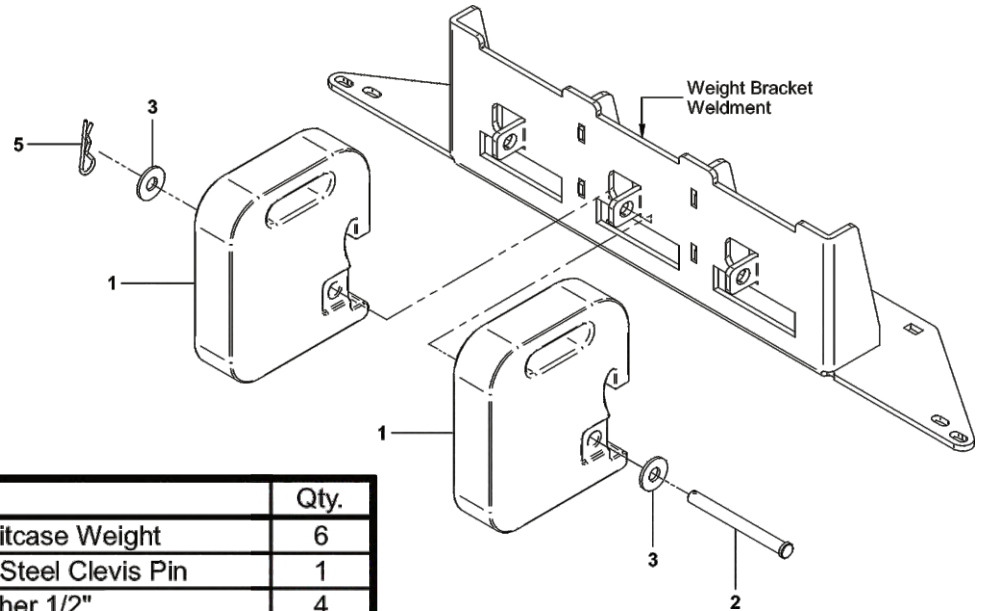
To install the (6) Weights, first insert the first (2) set of Weights (Item #1) Into the front center of the Weight Bracket Weldment & align the mount hole of the Weights w/ the hole on the Weight Bracket tab. Fasten the Weight to the Weight Bracket by using (1) Clevis Pin (Item #2), (2) 1/2" Flat Washer (Item #3) & (1) Hair Pin Clip (Item #5). See Figure A.

Then, insert the next (2) set of Weights (Item #1) Into either the front Left or Right side of the Weight Bracket Weldment & align the mount hole of the Weights w/ the hole on the Weight Bracket tab. Fasten the Weights to the Weight Bracket Weldment by using (1) Hitch Pin (Item #2), (1) 1/2" Flat Washer (Item #3) & (1) Hair Pin Clip (Item #5). See Figure B.

Repeat the last step to install the last set of Weights on the other side of the Weight Bracket Weldment.

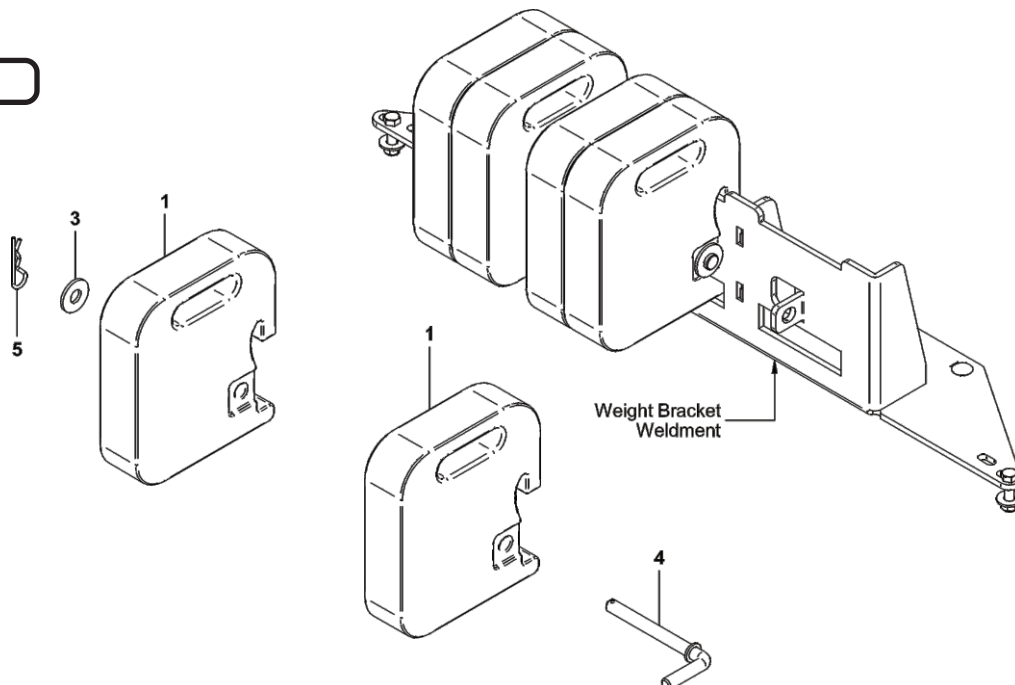
Note: Some parts and part features have been hidden from view for visual clarity.

Figure A



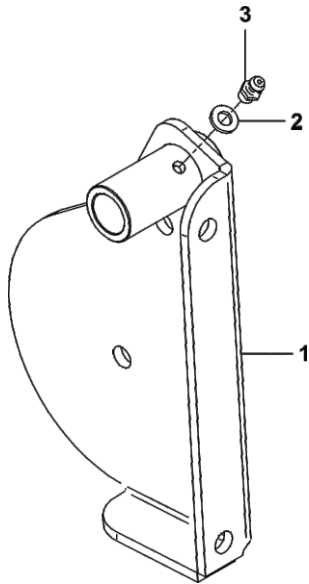
Item #	Part #	Desc.	Qty.
1	Y0025	28 lb. Suitcase Weight	6
2	K1482	1/2" x 5" Steel Clevis Pin	1
3	K0055	Flat Washer 1/2"	4
4	A0312	Hitch Pin Weldment	2
5	K0086	Hair Pin Clip .125 OD x 2.50	3

Figure B



## A2092 Idler Arm Assembly

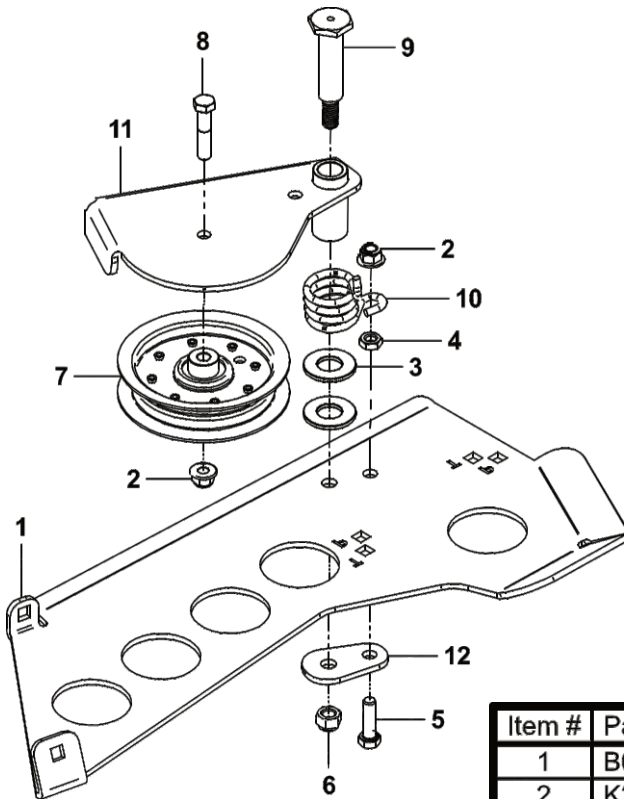
PTO-X



Item #	Part #	Desc.	Qty.
1	A2070_01	Idler Arm Weldment	1
2	K1467	Flat Washer M6 x 12mm OD	1
3	J0801	1/4\"-28 Zirc Fitting	1

## A2067 02 Idler Mount Assembly

PTO-X

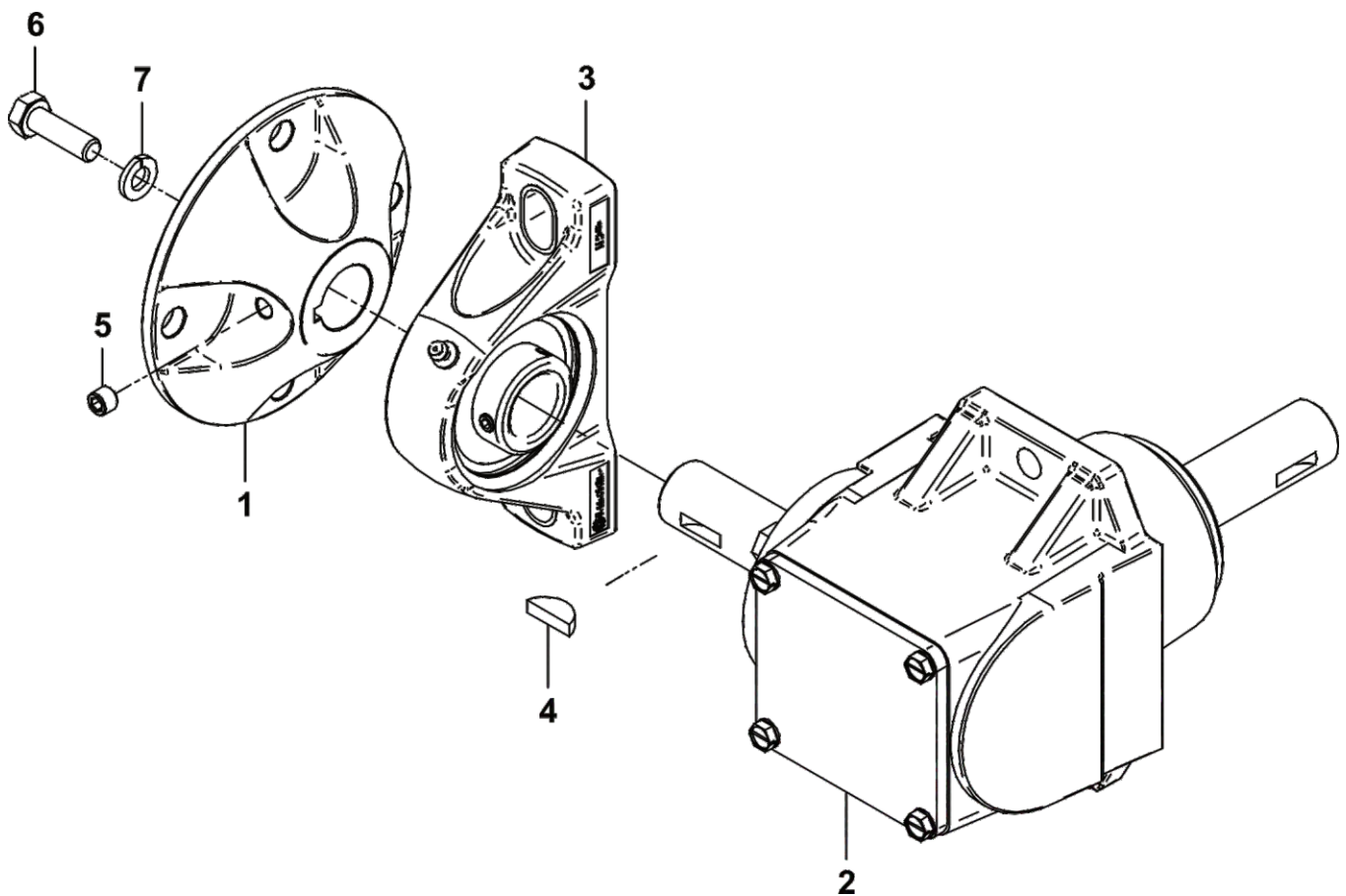


Item #	Part #	Desc.	Qty.
1	B0958_02	Idler Mnt Pl	1
2	K2038	Ny-Flange Lock Nut 3/8\"-16	2
3	K1463	Flat Washer .720 ID x 1.500 OD x .250 T	2
4	K1219	Jam Nut 3/8\"-16	1
5	K1192	HHCS 3/8\"-16 x 1-1/4\" GR5	1
6	K0329	Nylock Nut 7/16\"-14 GR8	1
7	M0003	Idler Pulley	1
8	K1462	HHCS 3/8\"-16 x 1-3/4\" GR8	1
9	K1464	Shoulder Bolt 7/16\"-14 / Idler	1
10	J0024	Torsion Spring	1
11	A2092	Idler Arm Assy.	1
12	B0974	Idler Base Plate	1

# A2058 01 Gearbox Sub-Assembly Exploded Parts View

PTO-X

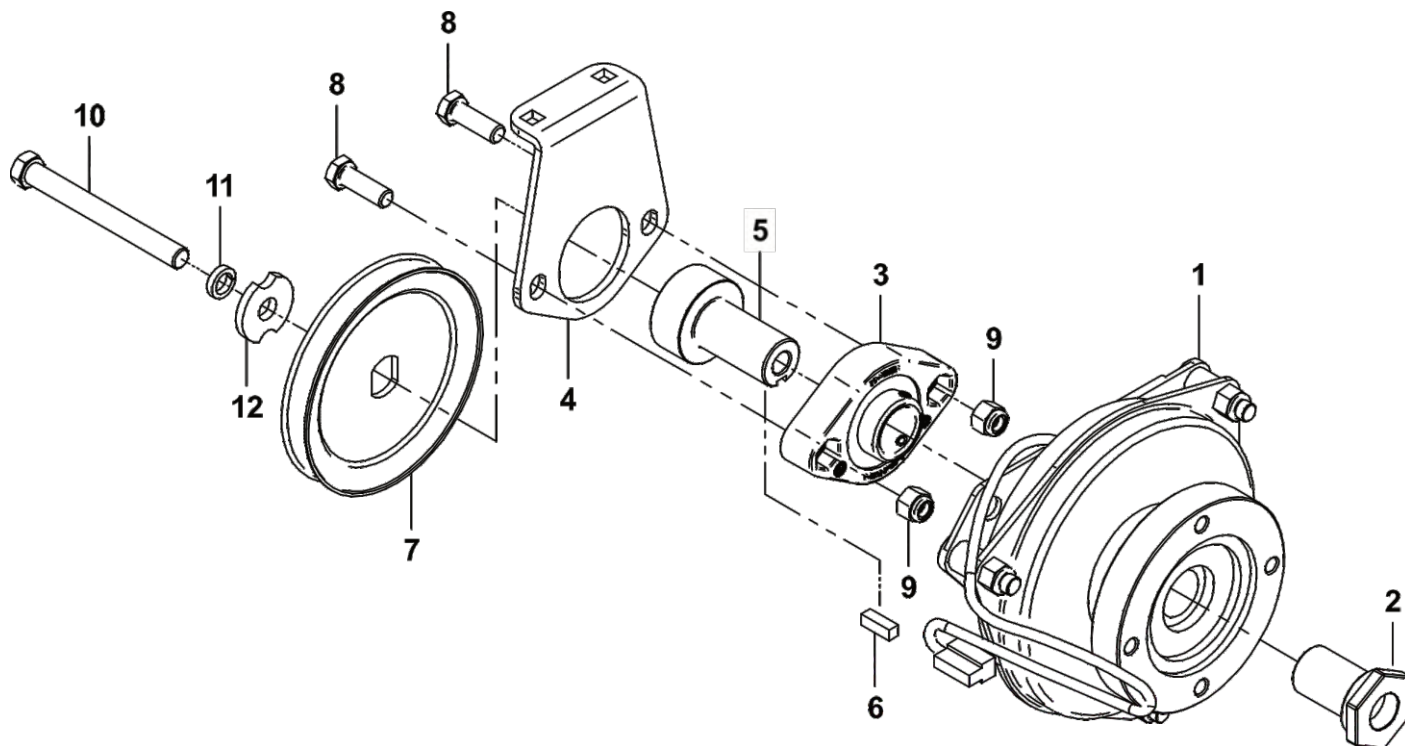
Item #	Part #	Desc.	Qty.
1	A2048	Clutch Flange	1
2	M0002	Gearbox	1
3	N0005	7/8" Pillow Block Bearing / Fenner	1
4	J0272	Woodruff Key #9	1
5	K0035	Set Screw 5/16"-18 x 1/4" Cup Point	1
6	K0428	HHCS 5/16"-24 x 1" GR8	1
7	K0043	Lock Washer 5/16"	1



# A2059 02 Clutch Sub-Assembly Exploded Parts View

PTO-X

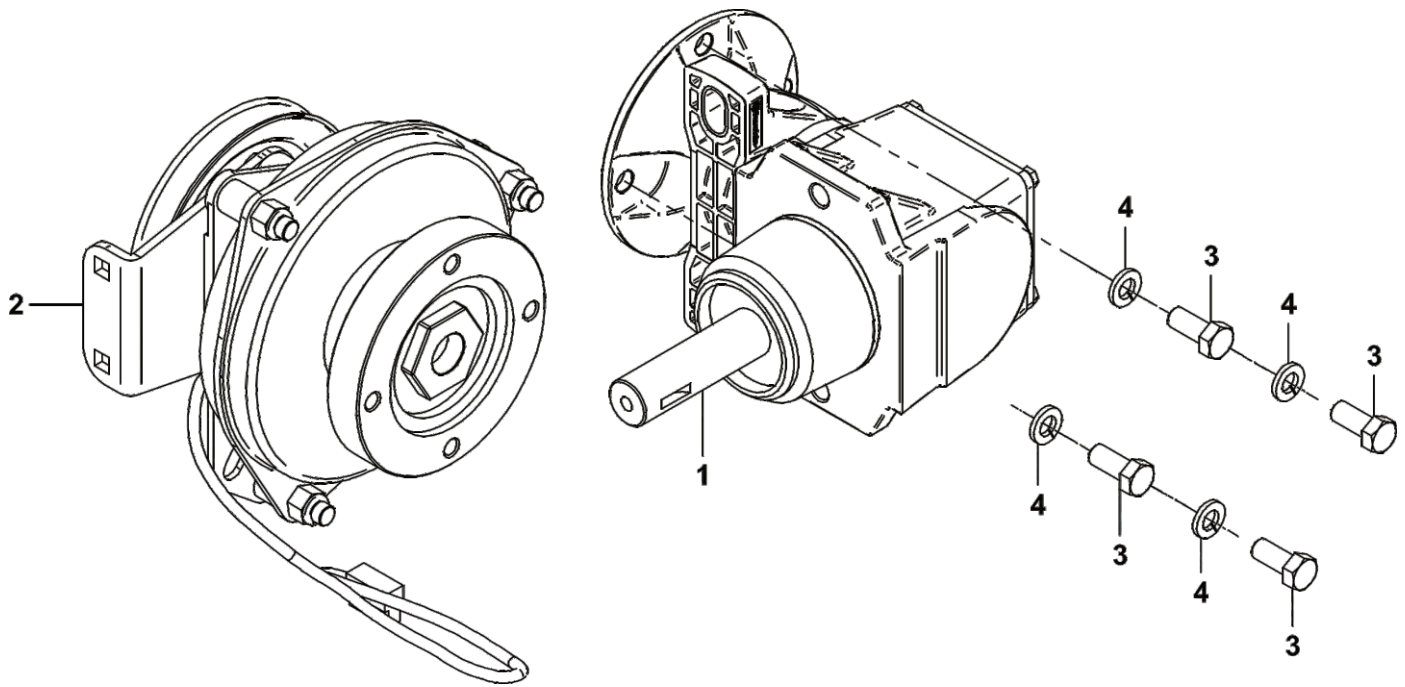
Item #	Part #	Desc.	Qty.
1	M0001_01	Electric Clutch	1
2	S0007	Clutch Shaft (Rev 1)	1
3	N0004	Flange Bearing / 1" ID / 2-Bolt	1
4	B2217	Clutch Lower Bearing Mnt.	1
5	S0239	Eng. Pulley Bushing #41	1
6	K0076	Key 1/4" x 3/4" Long	1
7	M0309	A-Section Pulley / 4.75 OD (PTO-X)	1
8	K1510	HHCS 3/8"-16 x 1-1/8" GR5 Zinc	2
9	K1121	3/8"-16 Nyloc Nut GR5	2
10	K0359	HHCS / 7/16"-20 x 4" w/ Patch	1
11	K0140	Lock Washer 7/16" / High-Collar Helical Spring	1
12	K0278	Double Indented Washer 7/16" / 1.375 OD x .440 ID x .179 T	1



# A2057 02 Drive Assembly Exploded Parts View

PTO-X

Item #	Part #	Desc.	Qty.
1	A2058_01	Gearbox Sub-Assy	1
2	A2059_02	Clutch Sub-Assy	1
3	K0343	HHCS 3/8"-16 x 7/8" GR8	4
4	K0048	Lock Washer 3/8"	4



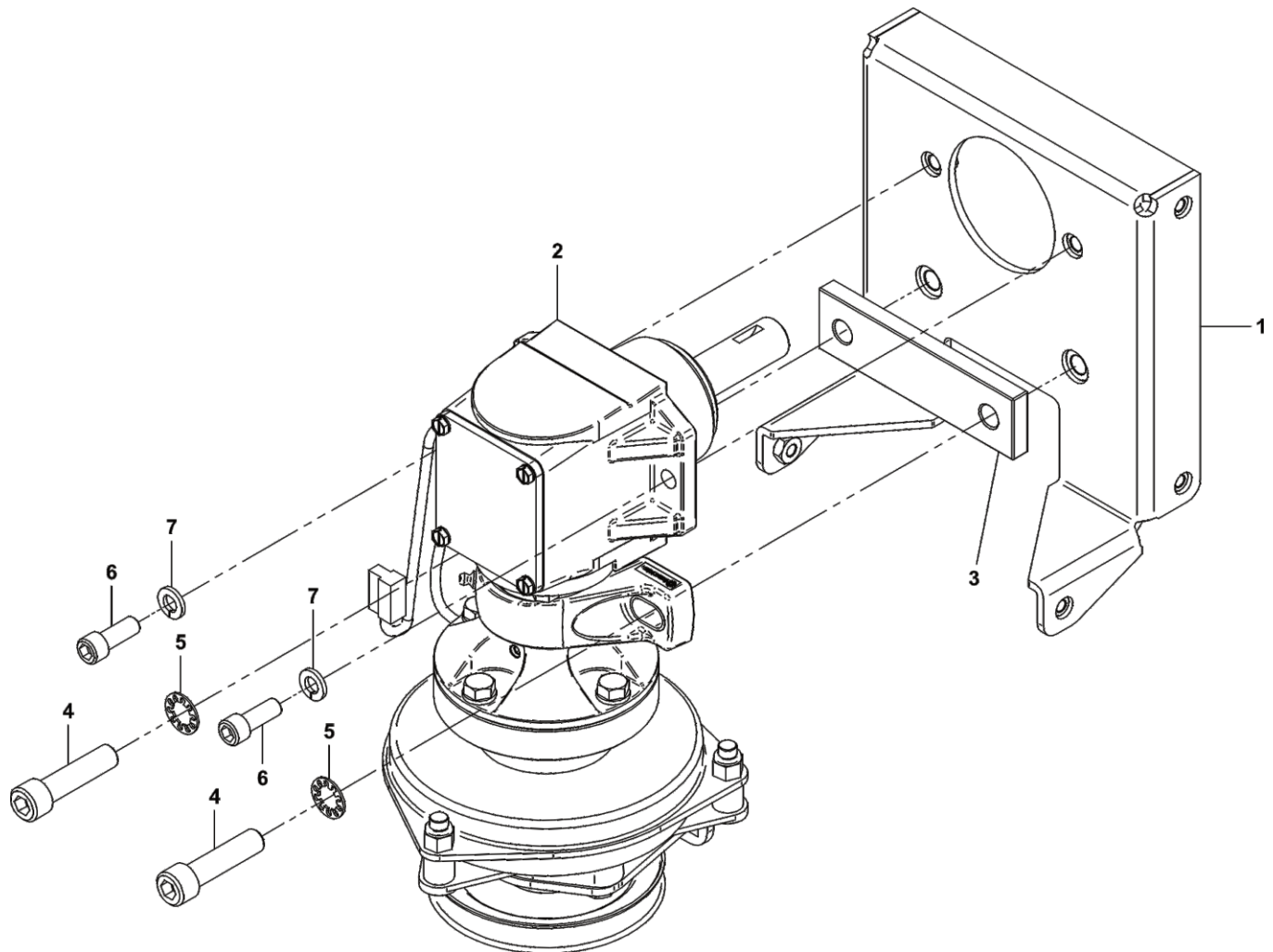


# A2060 02 Mounted Drive Assembly

PTO-X

## Exploded Parts View

Item #	Part #	Desc.	Qty.
1	A2034	Drive Mnt Assy	1
2	A2057_02	Drive Assy	1
3	B0940	Spacer Plate	1
4	K1511	SHCS 1/2"-13 x 2" A574 Zinc	2
5	K0057	Lock Washer I/T 1/2" / Zinc	2
6	K1512	SHCS 3/8"-16 x 1" A574 Zinc	2
7	K0048	Lock Washer 3/8"	2

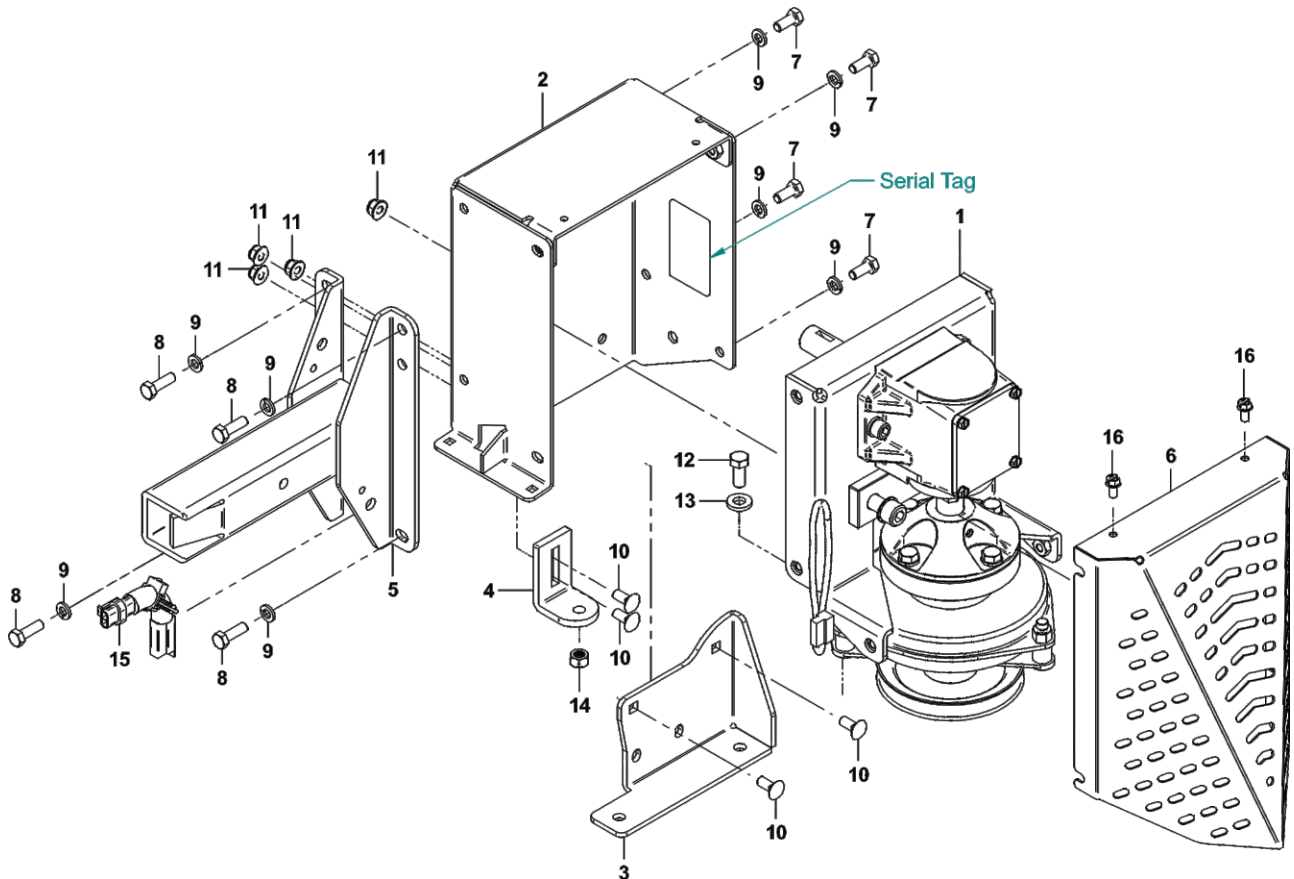


# A2039 03 Base Drive Assembly

PTO-X

## Exploded Parts View

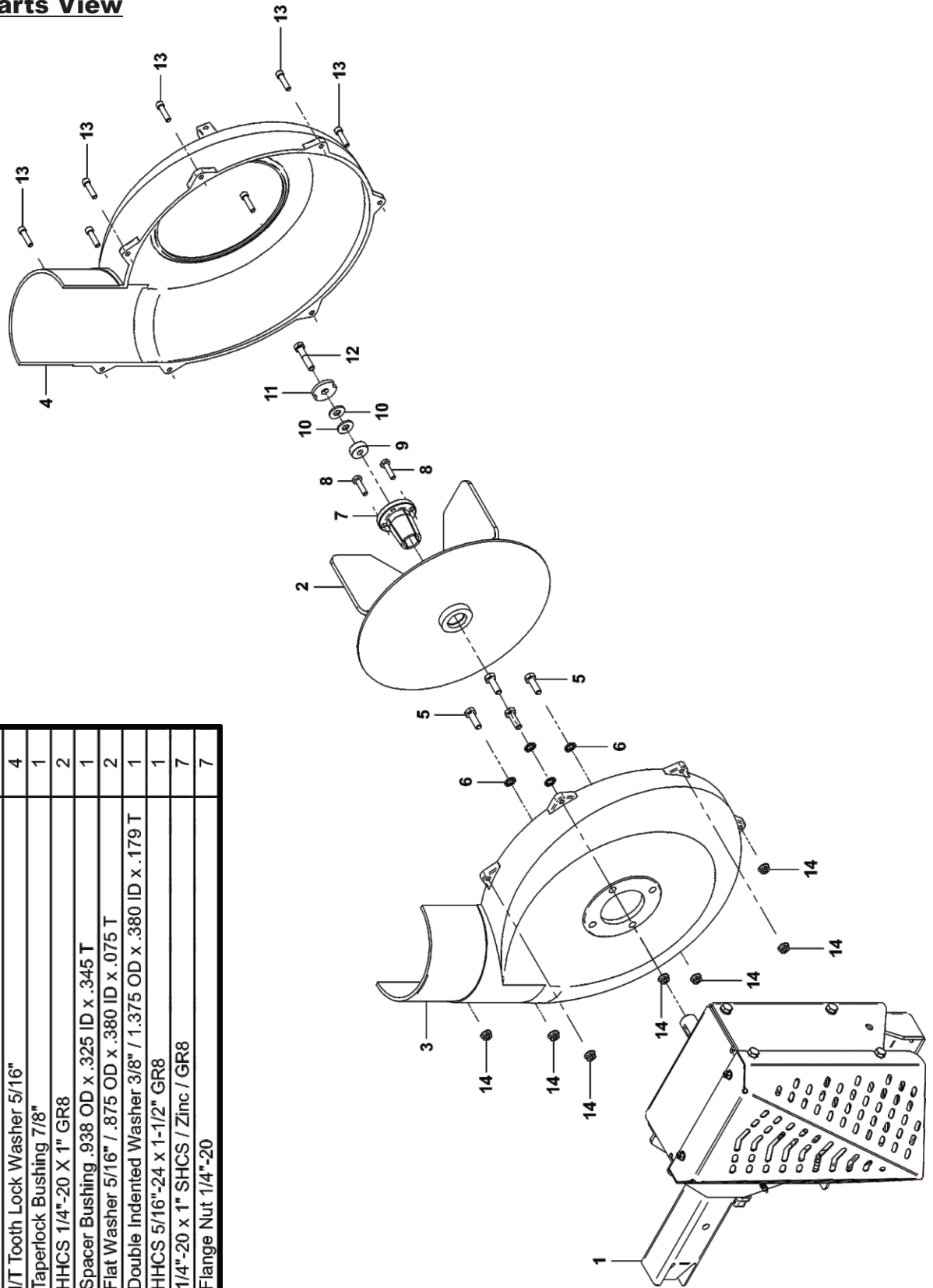
Item #	Part #	Desc.	Qty.
1	A2060_02	Mounted Drive Assy	1
2	A2035_02	Housing Mnt Assy	1
3	B1100_01	Idler Assy Mount Plate	1
4	B0942_02	Anti-Rotation Brkt	1
5	A2032	Drive Arm Assy	1
6	B0938_01	Drive Guard	1
7	K1153	HHCS 5/16"-18 x 3/4"	4
8	K1154	HHCS 5/16"-18 x 1"	4
9	K0043	Lock Washer 5/16"	8
10	K1142	5/16"-18 x 3/4" Carriage Bolt	6
11	K2516	Ny-Flange Lock Nut 5/16"-18	6
12	K0343	HHCS 3/8"-16 x 7/8" GR8	1
13	K1477	Flat Washer / 3/8" / .406 ID x .812 OD x .125 Thk	1
14	K1476	Reverse Lock Nut / 3/8"-16 Grade C	1
15	P0271	Quick Connect Wire Harness	1
16	K0353	HWHTCS 1/4"-20 x 1/2"	2



# A2061 03 Drive Assembly / 4 Blade Impeller

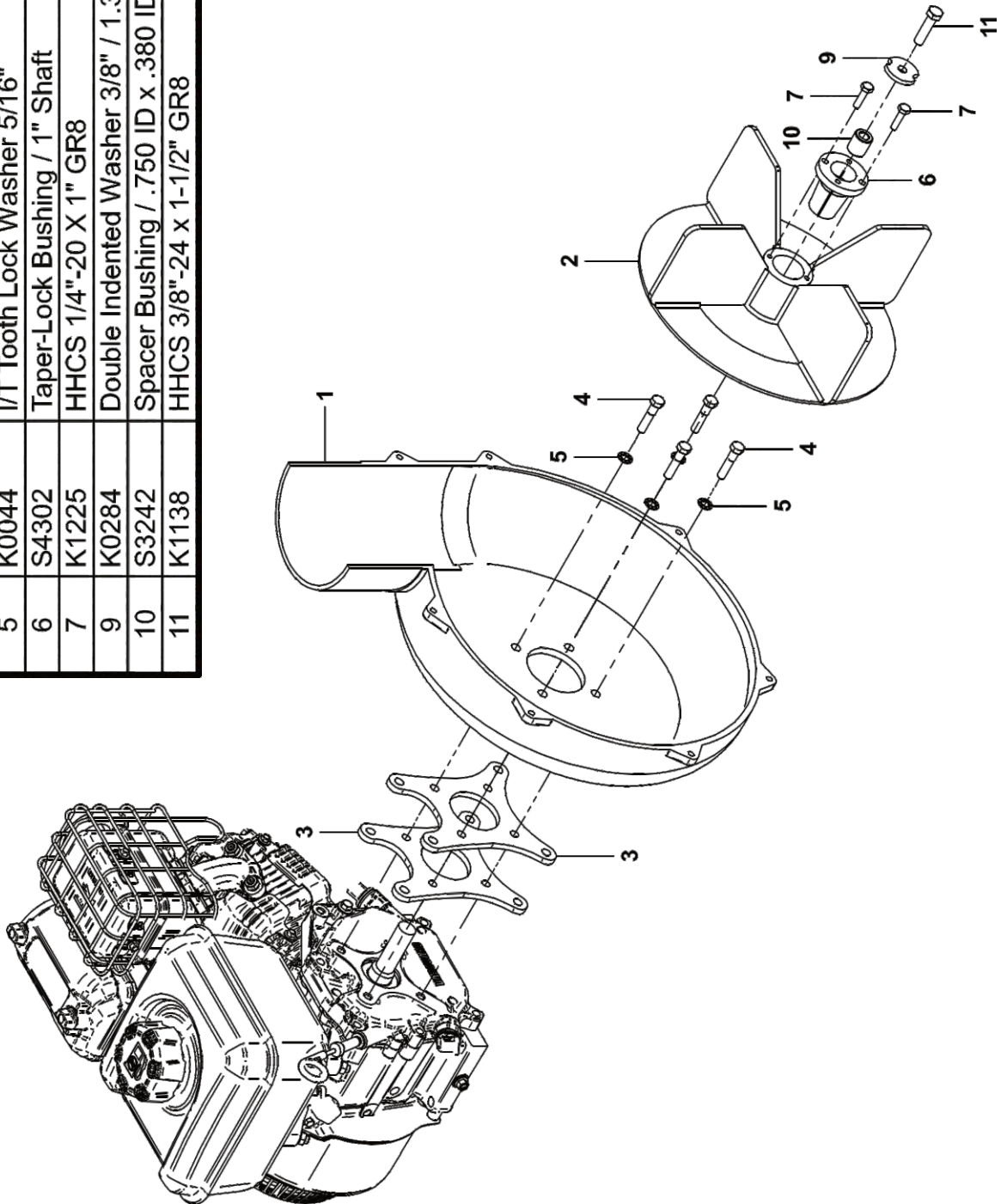
PTO-X

## Exploded Parts View



Item #	Part #	Desc.	Qty.
1	A2039 03	Drive Assy / Base 1.5	1
2	A0645	4-Blade Impeller Weldment	1
3	E4052B	Blower Hsg Back	1
4	E4052F	Blower Hsg Front	1
5	K1154	HHCS 5/16"-18 x 1"	4
6	K0044	I/T Tooth Lock Washer 5/16"	4
7	S0157	Taperlock Bushing 7/8"	1
8	K1225	HHCS 1/4"-20 X 1" GR8	2
9	S0159	Spacer Bushing .938 OD x .325 ID x .345 T	1
10	K0042	Flat Washer 5/16" / .875 OD x .380 ID x .075 T	2
11	K0284	Double Indented Washer 3/8" / 1.375 OD x .380 ID x .179 T	1
12	K1465	HHCS 5/16"-24 x 1-1/2" GR8	1
13	K1401	1/4"-20 x 1" SHCS / Zinc / GR8	7
14	K1126	Flange Nut 1/4"-20	7

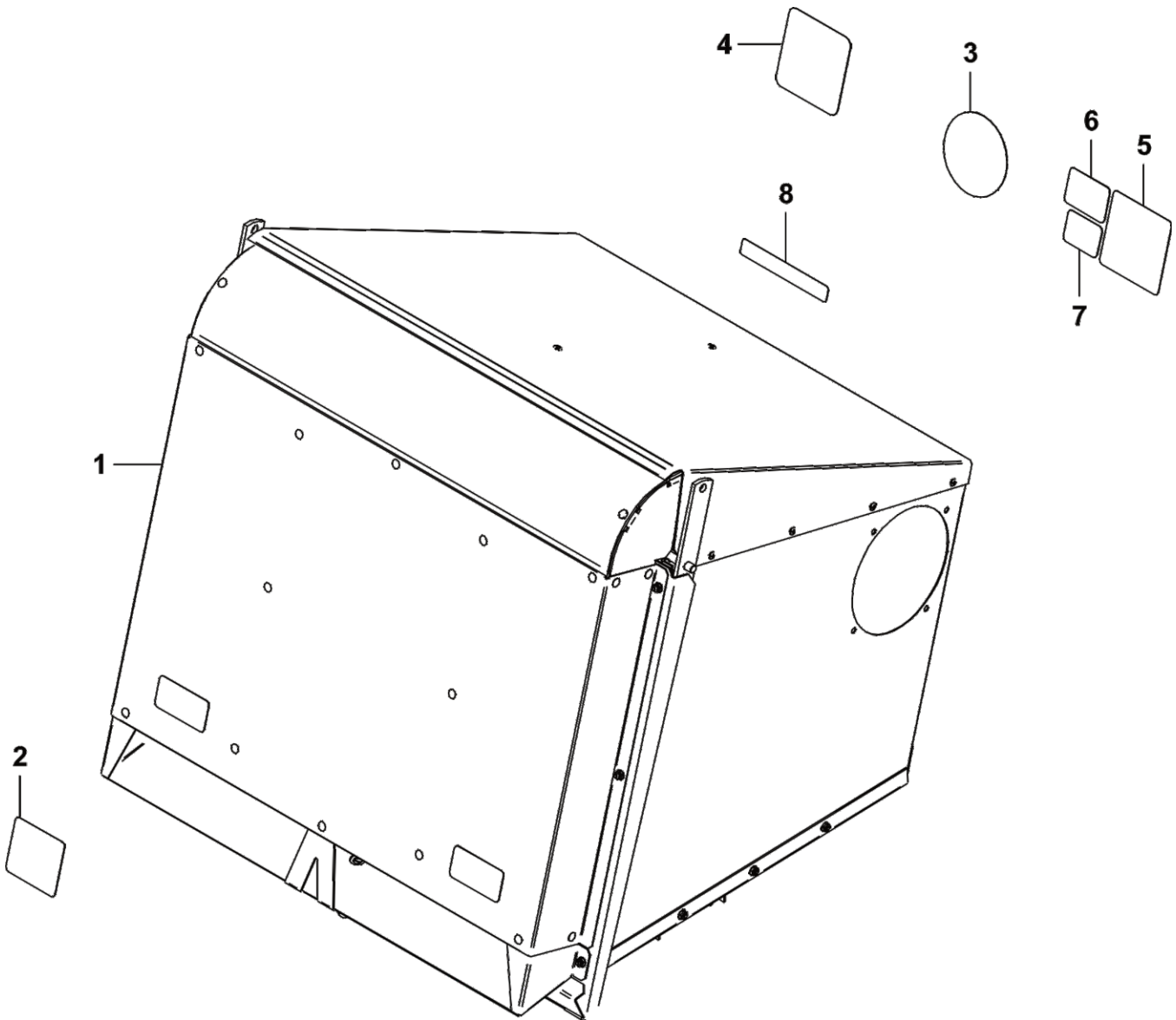
Item #	Part #	Desc.	Qty.
1	E4052B	Blower Hsg Back	1
2	A0645	4-Blade Impeller Weldment	1
3	B1933_01	Spacer / Blower Housing	2
4	K0374	5/16"-24 x 1-1/2" HHCS GR5	4
5	K0044	I/T Tooth Lock Washer 5/16"	4
6	S4302	Taper-Lock Bushing / 1" Shaft	1
7	K1225	HHCS 1/4"-20 X 1" GR8	2
9	K0284	Double Indented Washer 3/8" / 1.375 OD x .380 ID x .179 T	1
10	S3242	Spacer Bushing / .750 ID x .380 ID x .830 L	1
11	K1138	HHCS 3/8"-24 x 1-1/2" GR8	1



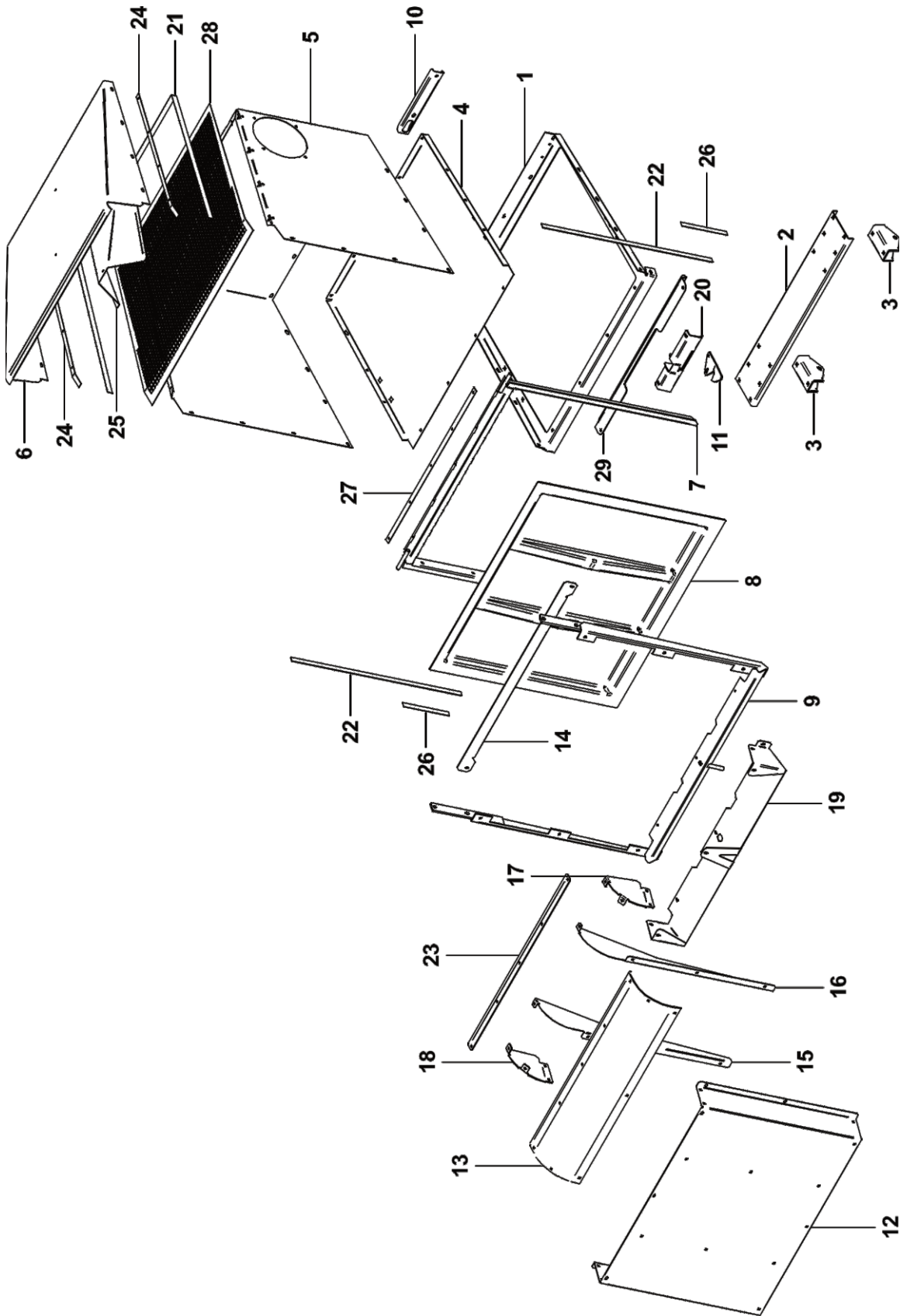
# A2100 6512 Box Assembly / Standard Model

## Exploded Parts View

Item #	Part #	Desc.	Qty.
1	A2226	6512 Box Assy. / Base Model	1
2	R1053	Decal / Caution	1
3	R0022	Decal / Built In The USA / Lg	1
4	R0026	Decal / Operation	1
5	R1069	Decal / Warning - Turn Off Blower	1
6	R1054	Decal / Important Check Hoses	1
7	R1051	Decal / Warning - Use Hearing Protection	1
8	R1055	Decal / To Dump Grass	1



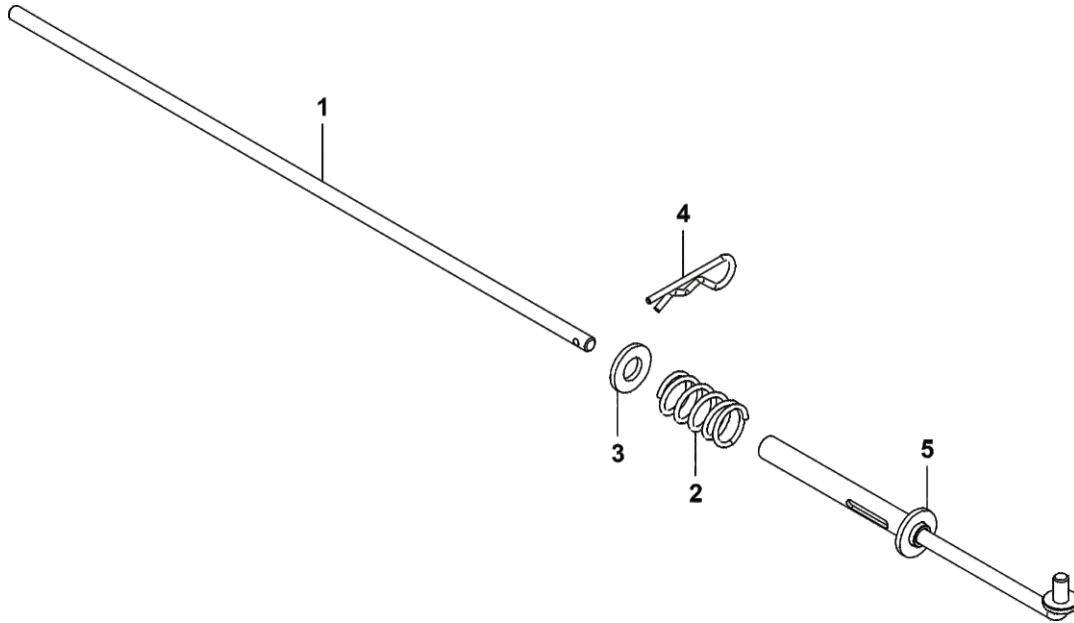
**A2226 6512 Box Assembly / Base Model**  
**Exploded Parts View**



**A2226 6512 Box Assembly / Base Model****Exploded Parts List**

Item #	Part #	Desc.	Qty.
1	B1750	Base Frame	1
2	B1727	Base Frame Pivot Mount	1
3	B1574	Pivot Bracket	2
4	C0024	Box Bottom	1
5	C0080	Box Back & Sides	1
6	C0081	Box Top	1
7	A0938	Frame Weldment / Box Opening	1
8	V1131	12 Box Door	1
9	A0738	Frame Weldment / Door Stiffener	1
10	B1730	Latch Handle Mount Bracket	1
11	B0996	Latch Hook	1
12	C0075	Dust Diverter	1
13	V0051	Dust Flap	1
14	B3688	Upper Door Member	1
15	C0076	Left Dust Diverter Brace	1
16	C0077	Right Dust Diverter Brace	1
17	C0079	Right Outer Dust Flap Brace	1
18	C0078	Left Outer Dust Flap Brace	1
19	B0991	Dust Diverter Guard Bracket	1
20	A2104	Latch Mount Plate Assy.	1
21	V0052A	Dust Seal / Top Sides	1
22	V0052B	Dust Seal / Long Door Sides	2
23	B1006	Dust Flap Stiffener	1
24	B1007	Screen Clamp Strip / Side	2
25	C0087	Screen Support	1
26	V0052C	Dust Seal / Short Door Sides	2
27	B1008	Screen Clamp Strip / Rear Door	1
28	B8113	Screen / Steel Wire Mesh	1
29	B2021	Box Stop / 6512	1

## A2107 Latch Rod Assembly



Item #	Part #	Desc.	Qty.
1	B1000	Latch Rod / Hook Side	1
2	J0303	Spring	1
3	K0400	1/2" Flat Washer 1.084 OD x .528 ID x .120 T	1
4	K0086	Hair Pin Clip .125 OD x 2.50	1
5	A2106	Latch Rod Weldment	1



# Unit Model #: 22651201

Mower: Toro Z-Master 4000 Series

Owner's Manual: Q0581

Mower Type:

Deck Size: 60"

Deck Type:

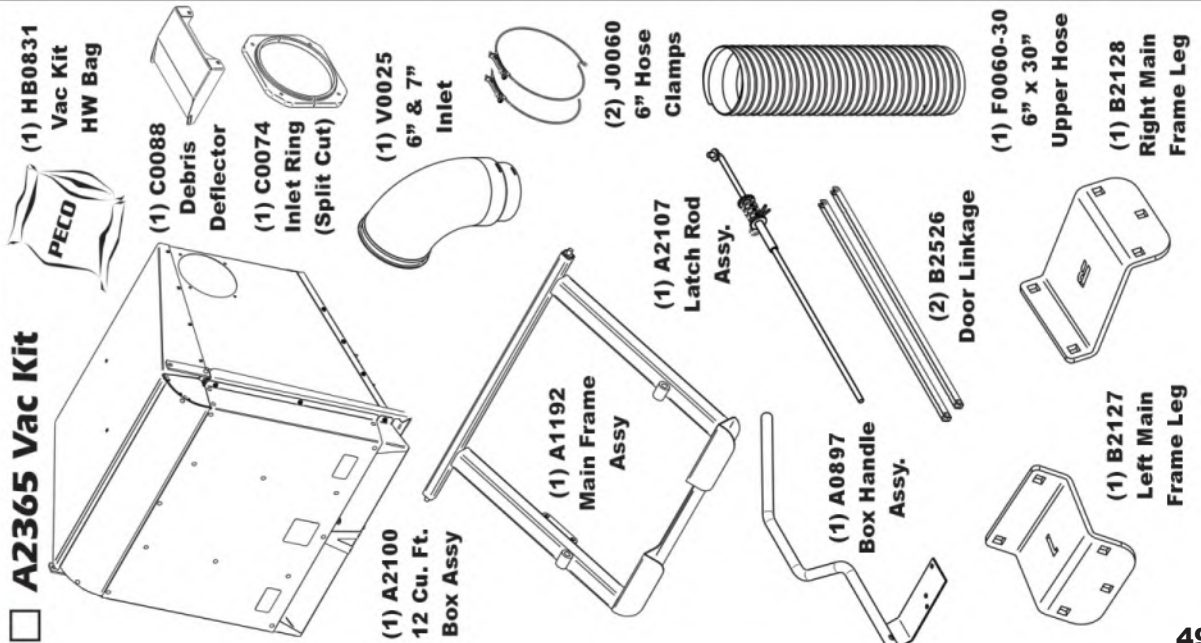
Vac Type: Pro12 DFS

Drive Type: PTO-X Drive

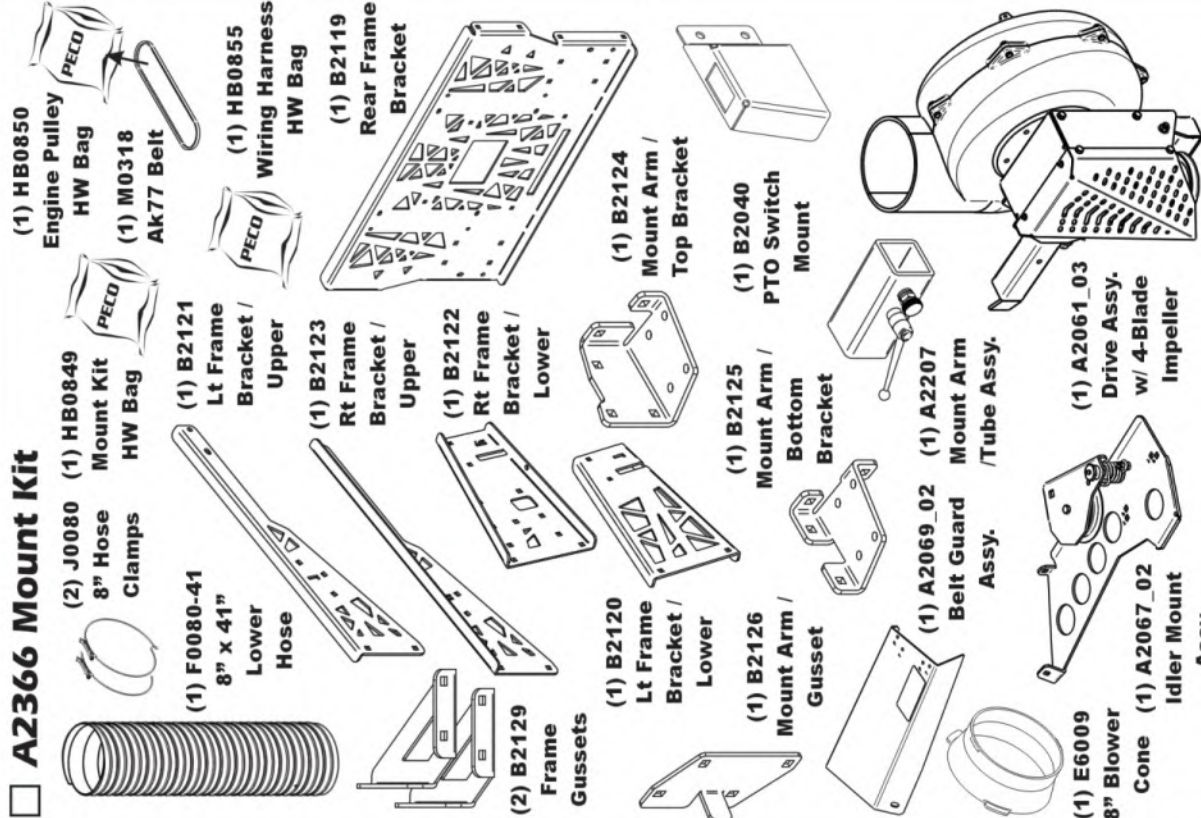
Fits Year(s): 2020 - Newer

Revision #: 2 PTO-X 1.5 - 6/24/24 BS

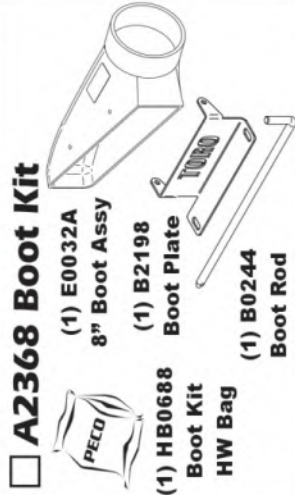
## ☐ A2365 Vac Kit



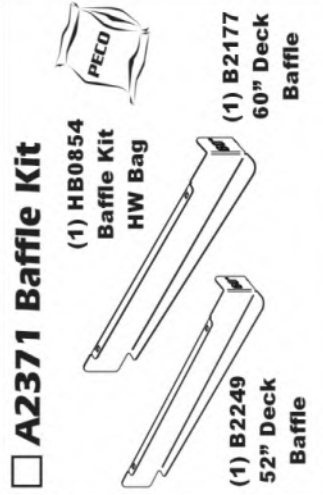
## ☐ A2366 Mount Kit



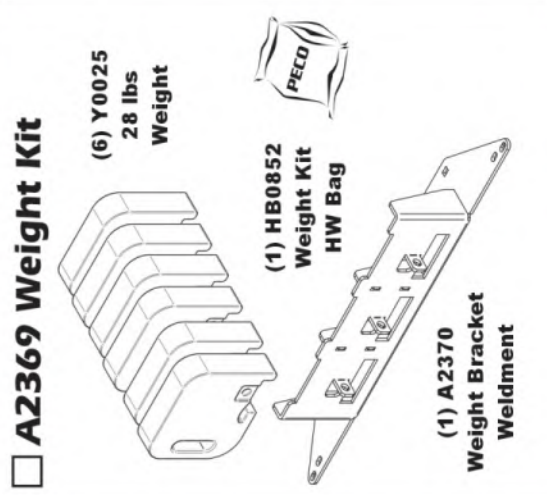
## ☐ A2368 Boot Kit



## ☐ A2371 Baffle Kit



## ☐ A2369 Weight Kit





# Unit Model #: 22651202

Mower: Toro Z-Master 4000 Series

Owner's Manual: Q0581

Mower Type:

Deck Size: 60"

Deck Type:

Vac Type: Pro12 DFS

Drive Type: Engine Drive

Fits Year[s]: 2020 - Newer

Revision #: 1 - Updated Wt & Baffle Kit (XY March 2023)

<p><input type="checkbox"/> <b>A2365 Vac Kit</b></p> <ul style="list-style-type: none"> <li>(1) HB0831 Vac Kit HW Bag</li> <li>(1) C0088 Debris Deflector</li> <li>(1) C0074 Inlet Ring (Split Cut)</li> <li>(1) V0025 6" &amp; 7" Inlet</li> <li>(1) A2100 12 Cu. Ft. Box Assy</li> <li>(1) A1192 Main Frame Assy</li> <li>(1) A0897 Box Handle Assy.</li> <li>(2) B2526 Door Linkage</li> <li>(1) B2127 Left Main Frame Leg</li> </ul>	<p><input type="checkbox"/> <b>A2367 Mount Kit</b></p> <ul style="list-style-type: none"> <li>(1) B2121 Lt Frame Bracket / Upper</li> <li>(2) J0080 8" Hose Clamps</li> <li>(1) F0080-41 8" x 41" Lower Hose</li> <li>(1) B2123 Rt Frame Bracket / Upper</li> <li>(1) B2129 Frame Gusset</li> <li>(1) B2120 Lt Frame Bracket / Lower</li> <li>(1) B2122 Rt Frame Bracket / Lower</li> <li>(1) B2119 Rear Frame Bracket</li> <li>(1) A0274 Engine Mnt Arm Assy</li> <li>(1) B3727 Outer Engine Mount Tube</li> <li>(2) B2204 Enging Mount Arm Spacer</li> </ul>	<p><input type="checkbox"/> <b>A2368 Boot Kit</b></p> <ul style="list-style-type: none"> <li>(1) E0032A 8" Boot Assy</li> <li>(1) B2198 Boot Plate</li> <li>(1) HB0688 Boot Kit HW Bag</li> <li>(1) B0244 Boot Rod</li> </ul> <p><input type="checkbox"/> <b>A2371 Baffle Kit</b></p> <ul style="list-style-type: none"> <li>(1) HB0854 Baffle Kit HW Bag</li> <li>(1) B2249 52" Deck Baffle</li> <li>(1) B2177 60" Deck Baffle</li> </ul>	<p><input type="checkbox"/> <b>A2369 Weight Kit</b></p> <ul style="list-style-type: none"> <li>(6) Y0025 28 lbs Weight</li> <li>(1) HB0852 Weight Kit HW Bag</li> <li>(1) A2370 Weight Bracket Weldment</li> </ul>
<p><input type="checkbox"/> <b>A0619 Throttle Kit</b></p> <ul style="list-style-type: none"> <li>(1) A0666 Throttle Mnt Plate Assy</li> <li>(1) HB0249 Throttle Kit HW Bag</li> <li>(1) A0060 70" Throttle Cable Kit</li> <li>(1) E6009 8" Blower Cone</li> <li>(1) A639 6.5HP B&amp;S Assy w/ 4-Blade Impeller</li> </ul>			

# SAFETY DECALS

To promote safe operation, New PECO, Inc. supplies safety decals on all products manufactured. Damage can occur to safety decals either through shipment, use or reconditioning. Contact your local Service Center for replacement decals.



Part# R1070  
PECO Logo



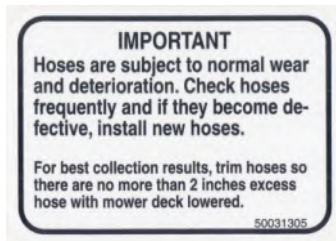
Part# R0022  
Designed & Built  
In The USA



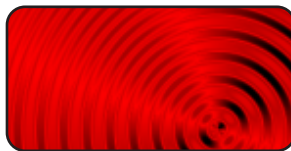
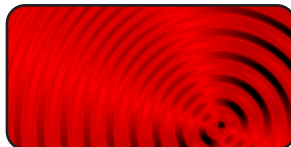
Part #: R2007  
Danger - Never Use Hands



Part #: R2008  
Danger - Rotating Blades



Part #: R1054  
Important - Hose Wear



Part #: R1057 - (2)  
Red Reflectors



Part #: R1069  
Warning - Turn Off Blower



Part # R0024  
Danger - Keep Hands  
Clear



Part #: R1051  
Warning - Hearing Protection



Part # R0025  
Danger - Rotating  
Blades

## SECTION III

# OPERATING INSTRUCTIONS

### General Safety

Only qualified people familiar with this operator's manual and the mower's operator's manual should operate this machine.

### Operation & Tips On Mowing

#### PTO-X

- A. Perform BEFORE EACH USE the maintenance list referenced in Section IV.
- B. Start mower.
- C. With the mower at high idle speed, engage the mower deck.
- D. While seated in the operator's seat, move Bagger PTO switch to the on position. With the PTO assembly engaged, you can proceed to operate the control levers of the mower.

#### Engine Drive

- A. Perform BEFORE EACH USE the maintenance list referenced in Section IV.
- B. Start the engine/blower/blade assembly.
- B. Start mower.
- C. With the mower at high idle speed, engage the mower deck.
- D. Proceed to operate the control levers of the mower.

**NOTE:** If the collection system does not appear to be collecting the grass clippings, disengage the deck and Drive assembly, then, engage the parking brake and turn the mower off. Check upper and lower hoses for any clogs.

To obtain the maximum effectiveness from your collection system, the tips listed below should be followed:

- \* Watch your speed- Normal conditions will allow a speed of up to approximately 4 mph, but thick, heavy damp conditions will require reduced ground speed.
- \* Mow with sharp blades- A sharp blade cuts cleaner.
- \* Wet grass and leaves will decrease effectiveness and will increase horsepower requirements.

- \* Mow at higher cutting heights- Remove and mulch no more than 2" of grass length with each mowing. (Experts recommend not cutting off more than 1/3 of the grass blade length at any given time.)
- \* Mow twice, at different height settings, (high, then low), if grass is extra tall.
- \* Remember that horsepower requirements will vary with the mowing conditions such as type and height of turf grass, moisture content, amount of leaves, whether the terrain is flat or hilly, etc.

### Disengagement Of The PTO Assembly

#### PTO-X

- A. To disengage the PTO assembly, move PTO Rocker Switch to the off position.

**WARNING:** DO NOT TOUCH the PTO assembly, pulleys, or the belt until the tractor is turned off.

### Unloading The Collection System

**NOTE:** Collection system blower will have an audible change in tone when the collection system is full.

- A. Stop the forward movement of the mower, engage the parking brake.
- B. Disengage the mower deck.
- C. Disengage the **PTO Drive** / set the throttle of the **Engine Drive** down to idle.
- D. Once the parking brake has been engaged, then and only then, walk behind the mower and check the collection bags by first unhooking the rubber strap with S-hook that secures the plastic top, then lift the plastic hood. Load in bags should not exceed the height of the installed bag.
- E. To remove the bags from the frame, slide bags out and turn bags over to deposit clippings.
- F. Slide empty bags back onto the frame and secure plastic top with the rubber strap with S-hook.

**NOTE:** Do not allow collection bags to become over-filled as potential damage may occur to your equipment. Also, be sure to clean the hood screen as needed.

## SECTION IV MAINTENANCE

### Maintenance Checklist

Before each use:

1. Check blades and spindles to be sure that no foreign objects, such as wire or steel strapping bands, are wrapped around them.
2. Inspect blades for wear. Replace if necessary. If it is necessary to sharpen the blades, remove the blades from the spindles before sharpening. DO NOT sharpen blades while still attached to the mower.
3. Make sure all shields are in place and in good condition. Repair or replace any missing or damaged shields.

#### 4. Perform lubrication per instructions.

5. Listen for abnormal sounds, which might indicate loose parts, damaged bearings, or other damage. Correct any deficiency before continuing operation.
6. With the engine off, engage the blower assembly. Check the belt tension and inspect the pulley belt for cracks or tears.
7. Check for wear or deterioration of the upper or lower hoses. If there are any portions of the hose that have been torn or worn through, replace immediately.

After Each Use:

1. Clean all debris from machine especially from the container, underneath the belt shields, and safety decals. Replace any missing or illegible decals.
2. Inspect the unit for worn or damaged components. Repair or replace before the next use. Any replacement component installed during repair shall include the component's current safety decal specified by the manufacturers to be affixed to the component.

3. Under normal usage, the collection unit is subject to deterioration and wear. Inspect the unit for worn or damaged components. Repair or replace before the next use. Any replacement component installed during repair shall include the component's current safety decal specified by the manufacturers to be affixed to the component.

#### 4. Check belt for proper tension.

### Lubrication

PTO-X

Gearbox:

**NOTE:** The gearbox is filled with 6.0 oz. of Mobilube HD Plus 80W-90 oil and permanently sealed. There is no need for scheduled lubrication. The oil level should only be checked if a leak is observed or if a change in gearbox noise is noticed.

Operators are recommended to check for leaks weekly. If a leak is observed, both the gasket and the seals are recommended to be replaced.

Replace the oil using 5.5 oz. of the recommended Mobilube HD Plus 80W-90 oil. Be sure to not overfill.

Blower Assembly:

**NOTE:** The following is for older PTO models that contain a greaseable zirc fitting. Newer models contain maintenance-free bearings and are without a greasable fitting.

1. On initial use: Grease the fitting on the blower shaft.
2. Every 25 hours of use: Re-grease the grease fitting.

**NOTE:** Use only white lithium based grease for lubrication of the shaft on the blower assembly.

## SECTION V - PARTS & SERVICE

### Parts And Service Information

Collection system owners should record the name and telephone number of their Service Center. Your Service Center will be happy to supply replacement parts, accessories, and do any service or repairs to your collection system. If for any reason your Service Center is unable to service your collection system or supply replacement parts, contact New PECO, Inc. and include the following information on the chart below.

### DOCUMENT THE FOLLOWING INFORMATION FOR FUTURE REFERENCE

**Unit Model Number:** \_\_\_\_\_

**Unit Engine Size:** \_\_\_\_\_

**Unit Serial Number:** \_\_\_\_\_

**Date of purchase:** \_\_\_\_/\_\_\_\_/\_\_\_\_

**Dealer/Distributor Name:** \_\_\_\_\_

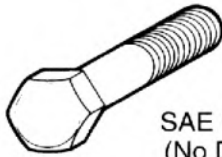
**Address:** \_\_\_\_\_ **State:** \_\_\_\_\_ **Zip:** \_\_\_\_\_

**Phone Number:** \_\_\_\_\_

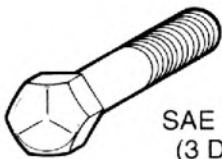
# TORQUE SPECIFICATIONS

Proper torque for American fasteners used on Peco equipment.  
Recommended Torque in Foot Pounds (Newton Meters).\*

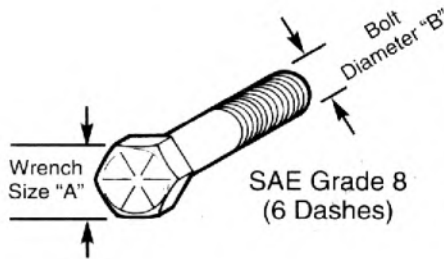
## AMERICAN Bolt Head Markings



SAE Grade 2  
(No Dashes)



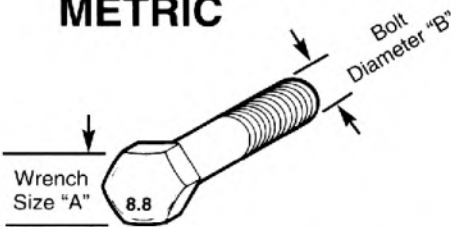
SAE Grade 5  
(3 Dashes)



SAE Grade 8  
(6 Dashes)

WRENCH SIZE (IN.) "A"	BOLT DIAMETER (IN.) "B" AND THREAD SIZE	SAE GRADE 2	SAE GRADE 5	SAE GRADE 8
7/16	1/4 - 20 UNC	6 (7)	8 (11)	12 (16)
7/16	1/4 - 28 UNF	6 (8)	10 (13)	14 (18)
1/2	5/16 - 18 UNC	11 (15)	17 (23)	25 (33)
1/2	5/16 - 24 UNF	13 (17)	19 (26)	27 (37)
9/16	3/8 - 16 UNC	20 (27)	31 (42)	44 (60)
9/16	3/8 - 24 UNF	23 (31)	35 (47)	49 (66)
5/8	7/16 - 14 UNC	32 (43)	49 (66)	70 (95)
5/8	7/16 - 20 UNF	36 (49)	55 (75)	78 (106)
3/4	1/2 - 13 UNC	49 (66)	76 (103)	106 (144)
3/4	1/2 - 20 UNF	55 (75)	85 (115)	120 (163)
7/8	9/16 - 12 UNC	70 (95)	109 (148)	153 (207)
7/8	9/16 - 18 UNF	79 (107)	122 (165)	172 (233)
15/16	5/8 - 11 UNC	97 (131)	150 (203)	212 (287)
15/16	5/8 - 18 UNF	110 (149)	170 (230)	240 (325)
1-1/8	3/4 - 10 UNC	144 (195)	266 (360)	376 (509)
1-1/8	3/4 - 16 UNF	192 (260)	297 (402)	420 (569)
1-5/16	7/8 - 9 UNC	166 (225)	430 (583)	606 (821)
1-5/16	7/8 - 14 UNF	184 (249)	474 (642)	668 (905)
1-1/2	1 - 8 UNC	250 (339)	644 (873)	909 (1232)
1-1/2	1 - 12 UNF	274 (371)	705 (955)	995 (1348)
1-1/2	1 - 14 UNF	280 (379)	721 (977)	1019 (1381)
1-11/16	1-1/8 - 7 UNC	354 (480)	795 (1077)	1288(1745)
1-11/16	1-1/8 - 12 UNF	397 (538)	890 (1206)	1444 (1957)
1-7/8	1-1/4 - 7 UNC	500 (678)	1120 (1518)	1817 (2462)
1-7/8	1-1/4 - 12 UNF	553 (749)	1241 (1682)	2013 (2728)
2-1/16	1-3/8 - 6 UNC	655 (887)	1470 (1992)	2382 (3228)
2-1/16	1-3/8 - 12 UNF	746 (1011)	1672 (2266)	2712 (3675)
2-1/4	1-1/2 - 6 UNC	870 (1179)	1950 (2642)	3161 (4283)
2-1/4	1-1/2 - 12 UNF	979 (1327)	2194 (2973)	3557 (4820)

## METRIC



Numbers appearing on bolt heads indicate ASTM class.

Proper torque for metric fasteners used on Peco equipment.  
Recommended torque in foot pounds (newton Meters).\*

WRENCH SIZE (mm) "A"	BOLT DIA. (mm) "B"	ASTM 4.6	ASTM 8.8	ASTM 9.8	ASTM 10.9
8	5	1.8 (2.4)		5.1 (6.9)	6.5 (8.8)
10	6	3 (4)		8.7 (12)	11.1 (15)
13	8	7.3 (10)		21.1 (29)	27 (37)
16	10	14.5 (20)		42 (57)	53 (72)
18	12	25 (34)	74 (100)	73 (99)	93 (126)
21	14	40 (54)	118 (160)	116 (157)	148 (201)
24	16	62 (84)	167 (226)	181 (245)	230 (312)
30	20	122 (165)	325 (440)		449 (608)
33	22		443 (600)		611 (828)
36	24	211 (286)	563 (763)		778 (1054)
41	27		821 (1112)		1138 (1542)
46	30	418 (566)	1119 (1516)		1547 (2096)

\*Use 75% of the specified torque value for plated fasteners. Use 85% of the specified torque values for lubricated fasteners.

# Troubleshooting

2017 (v1.0)

## Collection System Performance

<b>Problem</b>	<b>Possible Cause</b>	<b>Corrective Action</b>
Abnormal Vibration	<ul style="list-style-type: none"><li>• Cutting blades are bent or unbalanced</li><li>• Loose blower pulley or pulley assembly</li><li>• Impeller blade out of balance</li></ul>	<ul style="list-style-type: none"><li>• Install new cutting blade</li><li>• Tighten the pulley</li><li>• Contact dealer to replace</li></ul>
Reduced collection system performance	<ul style="list-style-type: none"><li>• Low engine speed</li><li>• Plugged screen</li><li>• Loose belt</li><li>• Full collection bags</li></ul>	<ul style="list-style-type: none"><li>• Always operate collection system at full throttle</li><li>• Remove debris, leaves, or grass clippings from the screen</li><li>• Replace/tighten belt</li><li>• Empty the collection bags</li></ul>
Blower and hoses plugging too frequently	<ul style="list-style-type: none"><li>• Collection bags are too full</li><li>• Low engine speed</li><li>• Grass is too wet</li><li>• Grass is too long</li><li>• Ground speed is too fast</li><li>• Worn belt</li><li>• Loose belt</li></ul>	<ul style="list-style-type: none"><li>• Dump more frequently</li><li>• Always operate collection system at full throttle</li><li>• Cut grass when it is dry</li><li>• Cut the grass several times</li><li>• Drive slower at full throttle</li><li>• Replace belt</li><li>• Adjust the pulley and tighten belts</li></ul>
Debris blowout	<ul style="list-style-type: none"><li>• Collection bags are too full</li><li>• Plug/clog in the collection system</li><li>• Ground speed is too fast</li></ul>	<ul style="list-style-type: none"><li>• Dump more frequently</li><li>• Clean the collection system</li><li>• Drive more slowly at full throttle</li></ul>
Impeller doesn't rotate freely	<ul style="list-style-type: none"><li>• Plug in the blower housing</li><li>• Worn impeller blade</li><li>• Shaft bearings bad/failing</li></ul>	<ul style="list-style-type: none"><li>• Clean the blower housing</li><li>• Contact dealer to replace</li><li>• Contact dealer to replace</li></ul>



**New PECO, Inc.**  
**10 Walden Dr | Arden, North Carolina 28704**  
**Phone: 1-800-438-5823 | 828-684-1234**  
**Fax: 828-684-0858**  
**Email: [peco@lawnvac.com](mailto:peco@lawnvac.com)**  
**Website: [www.lawnvac.com](http://www.lawnvac.com)**