



PTO-X DRIVEN - GRASS COLLECTION SYSTEM

Model# 49131507 (629KD-001A)

COUNTRY
CLIPPER
ZERO TURN MOWER

Charger 8000 & Boss XL 9000
Mower Year: 2021

Charger 8005 & Boss XL 9005
Mower Year: 2022-Newer



Deck Sizes: 52" & 60"

OPERATOR'S MANUAL

ASSEMBLY • OPERATION • MAINTENANCE

GRASS COLLECTION SYSTEM

TABLE OF CONTENTS

SECTION	PAGE	SECTION	PAGE
Safety	2	Bag Assembly	29
Safety Alert Symbols	3	Bag Assembly Installation	29
Warranty	4	Boot Kit Assy & Installation	30
I INTRODUCTION AND DESCRIPTION	5	Blower Cone Installation	31
Introduction	5	Length of Hose Adjustment	32
Description	5	Upper Hose Installation	32
II INSTALLATION FOR USE	5	Lower Hose to Blower Cone Installation	32
Preparation Of Mower	6-8	Lower Hose to Boot Installation	32
Rear Frame Bracket Installation	9-10	Wire Harness Installation	33-36
Side Frame Bracket Installation	11	Weight Kit Installation	37
Right & Left Frame Bracket Installation	12-13	Impeller Blade Removal/Replacement	38
Frame Gusset Installation	14-15	Exploded Views & Parts List	39-49
Mount Arm / Top Bracket Installation	16	Overall Parts List	50
Mount Arm / Bottom Bracket Installation	16	Safety Decals	51
Mount Arm / Gusset Installation	17	III OPERATING INSTRUCTIONS	52
Mount Arm / Tube Assembly Installation	18	General Safety	52
Lower Mount Tube Installation	19	Operation & Tips On Mowing	52
Upper Frame Assy Installation	20	Disengagement Of The PTO Assembly	52
PTO Drive Assembly	21-22	Unloading The Collection System	52
Drive Assy & Belt Installation	23	IV MAINTENANCE	52-53
Belt Tension Adjustment	24-26	Maintenance Checklist	53
Top Assy To Upper Frame Assy Installation	27	Lubrication	53
Inlet Installation	27	V PARTS AND SERVICE	53
Hinge Kit Assy Installation	28	Parts And Service Information	53
Even Bag Fill Adjustment	28	Torque Specifications	54
		Troubleshooting	55

SAFETY

1. Read the operator's manual carefully and familiarize yourself with the proper use of your attachment. Do not allow anyone who is not acquainted with the Safety Instructions to use your attachment.
2. Know the controls and how to stop them quickly. READ THE OPERATOR'S MANUAL!
3. Do not allow children to operate the machine. Do not allow adults to operate it without proper instruction.
4. Be especially watchful of children and pets entering into the area while operating.
5. Keep your eyes and mind on your machine while mowing or operating your attachment. Don't let others distract you.
6. Do not attempt to operate your machine when not in the driver's seat.
7. Always shut off blades and engine when emptying the container.
8. Stop machine, shut off deck attachment, set parking brake, shut off engine and remove ignition key before removing clogs, removing or replacing hose, boot, blower cone, or performing any maintenance.
9. Mow across the face of slopes (not more than 10 degrees); never up and down the face.
10. It is recommended that the container be emptied when half full while operating on slopes. Start mowing on slopes when the container is empty.
11. Inspect your lawn and remove any foreign objects before mowing. Never deliberately run the mower across any foreign object.
12. Wear hearing protection.
13. Wear eye protection to prevent debris from getting into your eyes.

SAFETY

WARNING! NEVER operate the mower unless the discharge guard and either the deflector assembly or the vacuum collector adapter are fastened securely in place.

WARNING! Do not work around the mower deck boot or the blower area until you are certain that the mower blades and the blower impeller have stopped rotating.

WARNING! To avoid serious injury, perform maintenance on the vacuum collector; **ONLY AFTER STOPPING THE MOWER'S ENGINE AND WAITING FOR ALL MOVING PARTS TO COME TO A COMPLETE STOP.** Set the parking brake. Always remove the ignition key before beginning maintenance.

WARNING! For your own personal safety, **ALWAYS mow ACROSS the face of slopes and NEVER UP and DOWN the face. NEVER attempt to mow excessively steep slopes, and use caution when turning on any slope.**

Safety Alert Symbol



This Safety Alert Symbol means: **“ATTENTION! BECOME ALERT! YOUR SAFETY IS INVOLVED!”**

This symbol is used to call attention to safety precautions that should be followed by the operator to avoid accidents. When you see this symbol, carefully read the message that follows and heed its advice. Failure to comply with safety precautions could result in death or serious bodily injury.

Safety Signs

The signal words **DANGER**, **WARNING**, and **CAUTION** are used on the equipment safety signs. These words



White letters on **RED**

This signal word indicates a potentially hazardous situation which, if not avoided, will result in death or serious injury.



Black letters on **ORANGE**

This signal word indicates a potentially hazardous situation which, if not avoided, could result in death or serious injury.

It may also be used to alert against unsafe practices.



Black letters on **YELLOW**

This signal word indicates a potentially hazardous situation which, if not avoided, will result in minor or moderate injury.

It may also be used to alert against unsafe practices.

PECO LIMITED WARRANTY FOR NEW PRODUCTS

New PECO, Inc. extends the following warranties to the ORIGINAL PURCHASER of each New PECO, Inc. consumer product purchased from one of our Dealers or directly from New PECO, Inc., subject to the following limitations:

A. ITEMS COVERED UNDER WARRANTY

1. **PRODUCT WARRANTY** – Any part or parts which are deemed defective in material or workmanship, as delivered to the original purchaser, will either be repaired or replaced, as New PECO, Inc. elects, without charge for parts or labor, if the defect appears within 12 months from the date of purchase of the product to the Original Purchaser.
2. **PARTS REPLACED DURING WARRANTY** – Any New PECO, Inc. part which is furnished in performance of this warranty and is defective in material or workmanship as delivered to the purchaser will be repaired or replaced, as New PECO, Inc. elects, before the expiration of the original warranty period.

B. WARRANTY DISTINCTIONS

1. **RESIDENTIAL** - Products put to a personal use around a single household or residence are considered Residential. Products designated as “Residential” are warranted for 12 months from the date of purchase of the product, to the ORIGINAL PURCHASER with proof of purchase, when used for or in residential applications.
2. **COMMERCIAL** – Products put to any business use (agricultural, commercial or industrial) or used at multiple locations are considered Commercial. Products designated as “Commercial” are warranted for 12 months from the date of purchase of the product, to the ORIGINAL PURCHASER with proof of purchase, when used for or in commercial applications. Products designated as “Residential” are warranted for 90 days from the date of purchase of the product, to the ORIGINAL PURCHASER with proof of purchase, when used for or in Commercial applications.
3. **RENTAL** – Products used for Rental or Lease Purposes are warranted for 45 days from date of purchase of the product, to the ORIGINAL PURCHASER with proof of purchase, when used for or in a rental business.

C. ITEMS NOT COVERED BY NEW PECO WARRANTY

1. **ENGINES & BATTERIES:** Engines and Batteries attached to New PECO, Inc. products are covered under their respective separate manufacturer warranties and those companies must be contacted directly to file a warranty claim. Briggs & Stratton: https://www.briggsandstratton.com/na/en_us/support/warranty.html
2. **UNAPPROVED ALTERATION OR MODIFICATION:** All obligations of New PECO, Inc. under this warranty shall be terminated if products are altered or modified in any way not approved by New PECO, Inc.
3. **ACCIDENTS & NORMAL MAINTENANCE:** This warranty covers ONLY manufacturers defective material and workmanship. It does not cover depreciation or damage caused by normal wear & tear, accident, improper maintenance, misuse or abuse of products. New PECO, Inc. products must be operated and maintained in accordance with the instructions furnished in the manuals. The cost of normal maintenance and normal replacement of service items such as belts, cutting blades, hoses, bags, etc., which are not defective shall be paid for by the purchaser.
4. **NO SERVICE CENTER WARRANTY:** The selling Service Center/Dealer makes no warranty on his own on any item warranted by New PECO, Inc. unless he delivers to purchaser a separate written warranty certificate specifically warranting the item. The Service Center or Dealer has no authority to make any representation or promise on behalf of New PECO, Inc. or to modify the terms of the original warranty in any way.
5. **NO REPRESENTATIONS ADDITIONAL WARRANTIES, DISCLAIMER:** Neither New PECO, Inc. nor any company affiliated with New PECO, Inc. makes any warranties, representations or promises as to the quality of performance of its products other than those set forth herein. Except as described above, New PECO, Inc. makes no other warranties **AND SPECIFICALLY DISCLAIMS ANY AND ALL IMPLIED WARRANTIES OF FITNESS AND MERCHANTABILITY.**
6. **REMEDIED EXCLUSIVE:** The only remedies the purchaser has in connection with the breach or performance of any warranty on New PECO, Inc. consumer products are set forth above. In no event will New PECO, Inc. be liable for special incidental or consequential damages.

Warranty service is available through your local authorized service dealer or distributor. If you do not know the dealer or distributor in your area, search by your zip code on www.lawnvac.com or contact our Sales Department at New PECO, Inc. 800-438-5823 or email Sales@lawnvac.com.

Section I - INTRODUCTION AND DESCRIPTION

Introduction

We are pleased to have you as a customer. Your collection system has been designed to give you a low maintenance, simple, and effective way to collect the grass clippings from your mower. This manual is provided to give you the necessary instructions to properly mount, operate and maintain the collection system on your mower. Please read this manual thoroughly. Understand what each control is for and how to use it. Observe all safety decal precautions on the machine and noted throughout the manual.

NOTE: All references made to right, left, front, rear, top or bottom are as viewed from the normal operator's position on the mower.

Description

The grass collection system is designed for turf maintenance where there is a need to collect the grass clippings as the mower cuts the turf. It is also used for picking up leaves in pre-season and post-season clean-up. The blower, mounted on the right side of the unit, uses a belt and gearbox system from the engine PTO shaft. Drive train protection comes through belt slippage. The blower draws grass clippings from the discharge area of the cutting deck back to the collection bags at the rear portion of the mower. The operator can engage the blower with a toggle Switch mounted on the right side of the operator. Once the collection bags are full with clippings, they can be easily removed for dumping.



Note: There are different installation instructions between the model years. Installations for specific units will be specified under the current section heading or where needed as:

MY2021

or

MY2022

MY2021 & MY2022 will also share similar installation instructions. These instructions will not have any specification under the section heading.

Section II - INSTALLATION FOR USE

Preparation Of Mower

NOTE: The mower deck PTO belt must be removed from the electric clutch before continuing with the installation. Refer to your mower's owner's manual for instructions on PTO belt removal.

From the underside of the engine, disconnect the wiring harness attached to the electric clutch. Remove the bolt and electric clutch from the mower. Refer to Figure A.

Figure A

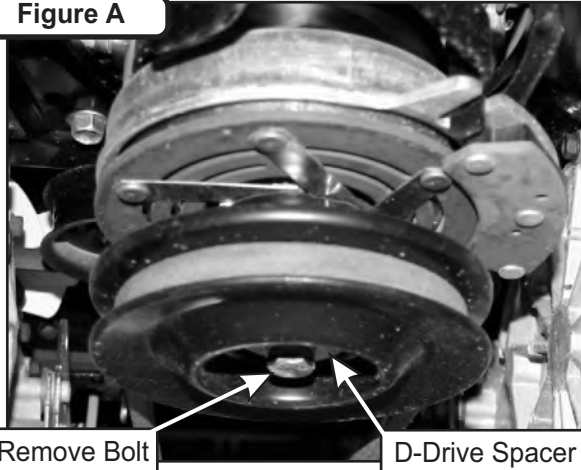

Upon removal of clutch determine if your mower is equipped with a D-drive spacer. If so, then proceed to Figure B. If your mower is equipped with bolt, fender and lock washer without D-drive spacer proceed to Figure C. Remove the D-drive spacer using an arbor press or equivalent. On removal, adjacent bearing OUTER race must be supported or bearing damage may occur. Refer to Figure B.

Figure B

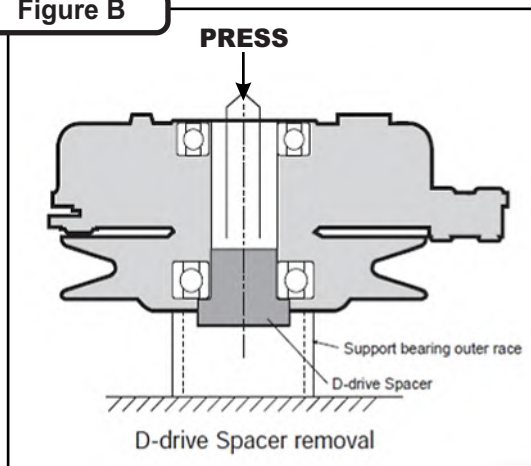
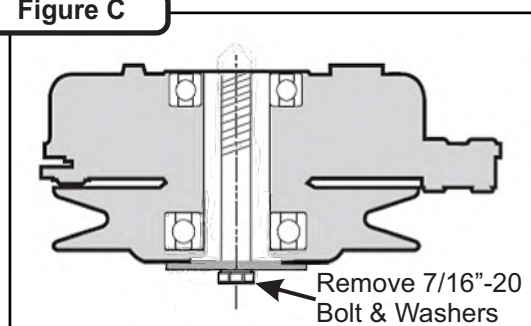
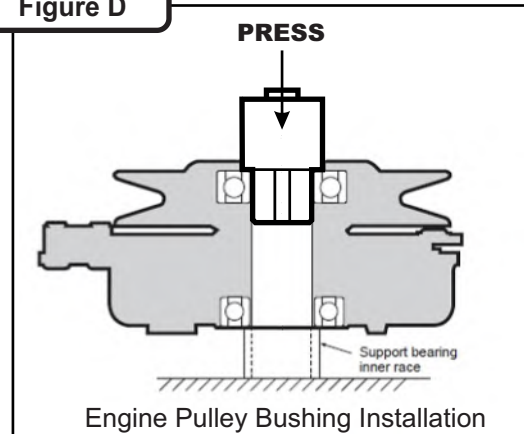

Figure C



The engine pulley assembly must be installed using an arbor press or equivalent. During installation, opposite bearing inner race must be supported or bearing damage may occur. Refer to Figure D.

Figure D



Once the Engine Pulley Bushing is installed, reattach the clutch assembly & deck PTO belt to the mower and then review Figure E.

Figure E

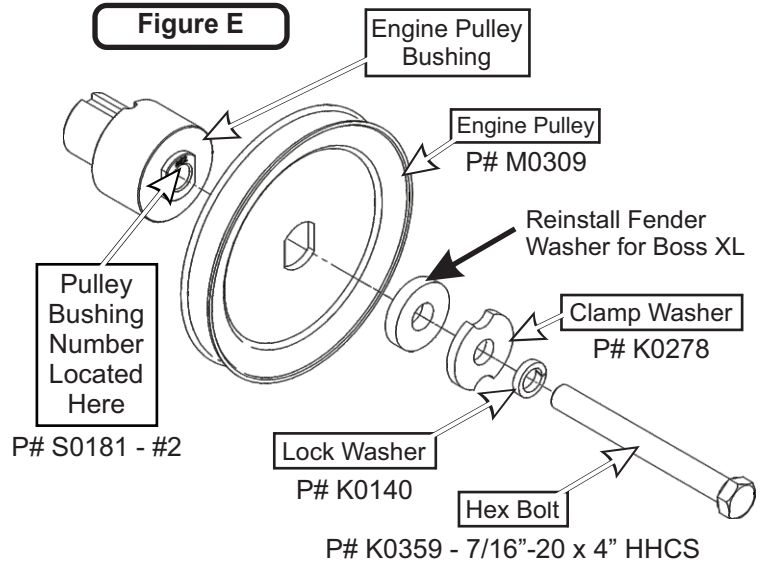

To assemble and fasten the Engine Pulley, align the Engine Pulley Bushing to the mower's clutch pulley and fasten using (1) Clamp Washer, (1) Lock Washer, and (1) Hex Bolt. Torque the bolt to 55 ft./lbs. For **Boss XL** units, reinstall the Fender Washer that was removed during the initial process. The added pulley will power the collection system and should resemble Figure F when installed.

Figure F

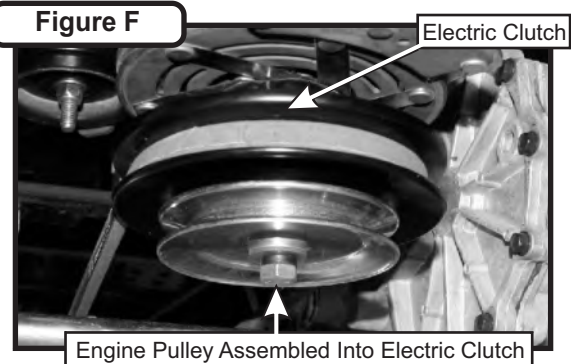

Preparation of Mower (Continued)

Before the installation of your unit, you will need to remove your mower's rear bracket along with the hardware holding it in place, see Figure G. Set the top set of hardware aside, see Figure H.

Note: Some parts and part features have been hidden from view for visual clarity.

Figure G

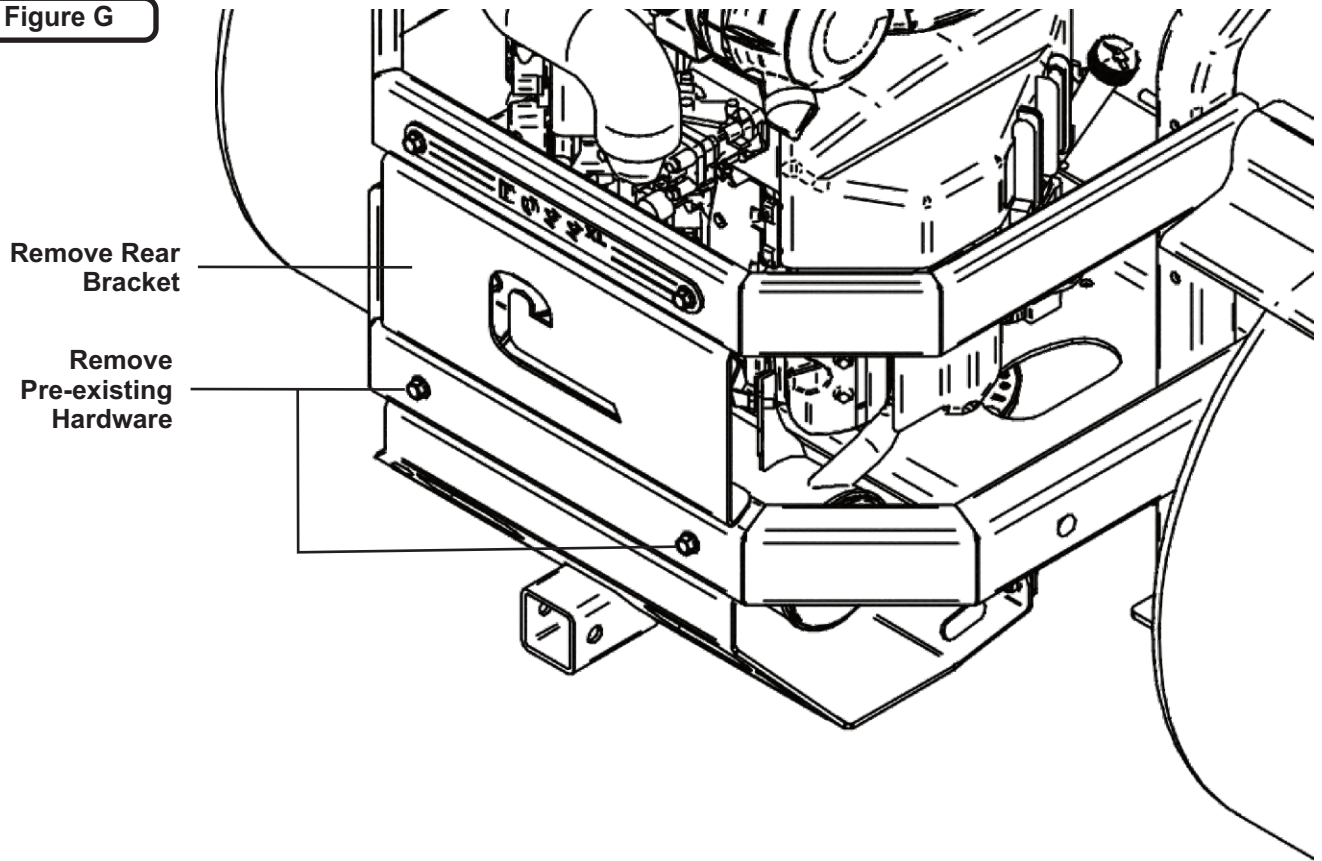
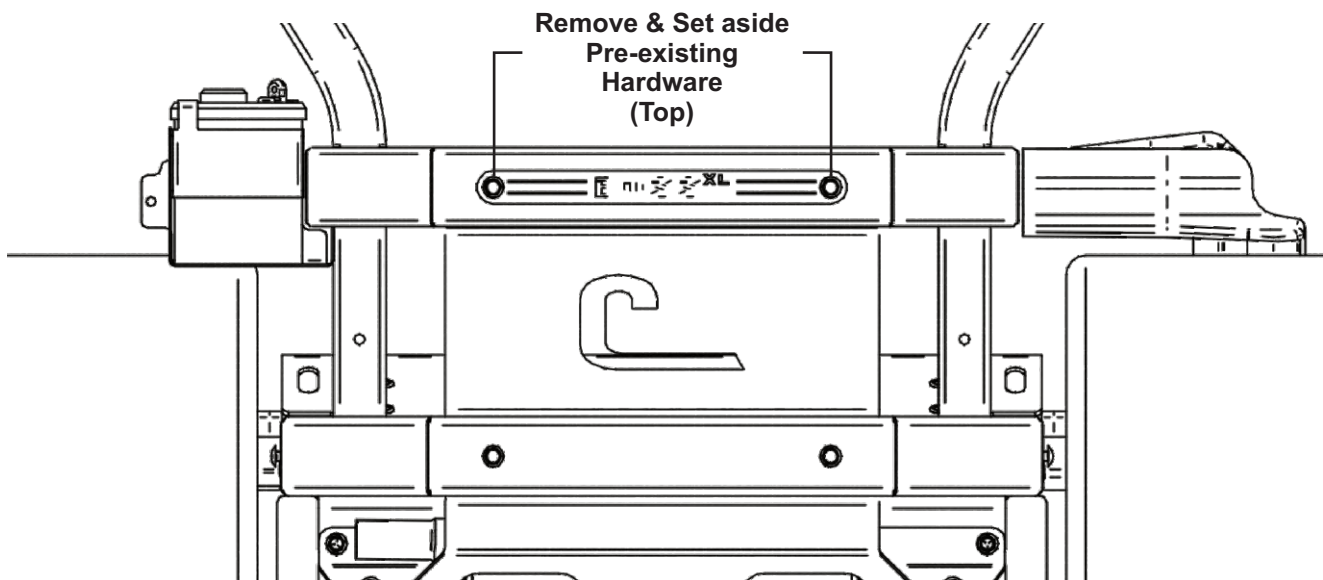

Figure H

Mower Rear View



Preparation of Mower (Continued)

ROPS Hinge Configuration

Your mower's ROPS will need to be reconfigured for the installation of your Bagger system from its standard position. The reconfiguration will allow you to lay the top post back approximately 90° when folded down. The Bagger Configuration will move the Hinge point from the lower post to the top post. With this New Hinge Point, re-tighten the 1/2" bolt to allow a level of drag. This will prevent the top post from bouncing when lowered which may cause potential damage to your bagger top, see Figure I.

Note: Some parts and part features have been hidden from view for visual clarity.

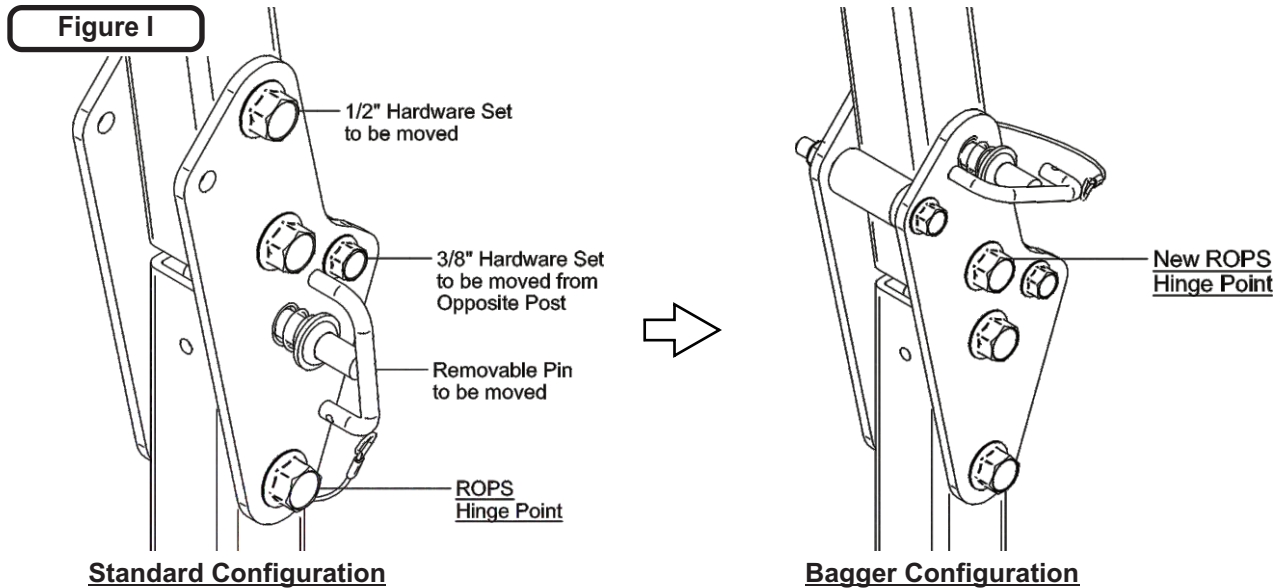

You'll need to identify, remove and reinstall (3) sets of hardware from each side posts, refer to Figure I above.

First, remove the Removable Pins, 3/8" Hardware w/ Urethane Bumper from one side and the set of 1/2" Hardware including the Shim Washers. Next, for reconfiguration: (1) Reinstall the Removal Pin to top post, (2) Reinstall the 1/2" Hardware w/ Shim Washers to lower post, and (3) Reinstall the 3/8" Hardware w/ Urethane Bumper to the Front Side of the Top Post. Refer to Figure J below for a breakdown of the reinstallation steps.

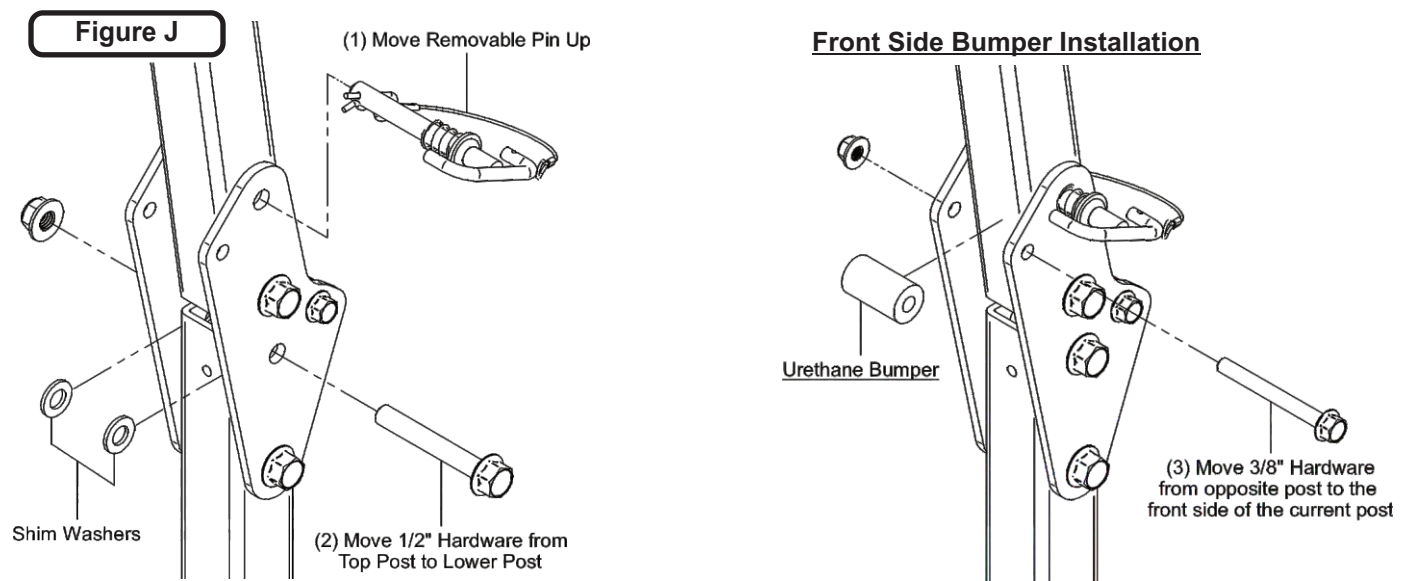

Note: (2) For an easier removal / installation of the Shim Washers, it is recommended to loosen all hardware before removal / installation then re-tightening after the installation.

Note: (3) Remove the Removable Pin before installation For an easier installation of the Urethane Bumper.

It is recommended to position the urethane bumper to the rear side of the lower post and to the front side of the top post on the same side of the ROPS as shown in Figure J above. The urethane bumper can be moved from one post of the ROPS to the other. Be sure to not over tighten the 3/8" Bolt that is securing the urethane bumper, instead tighten the bolt to a snug and firm fit.

Rear Frame Bracket Installation

MY2021

To install the Rear Frame Bracket (Item #1) align the mount holes of the Rear Frame Bracket to those on the Mower's rear frame, see the figure below.

Secure the Rear Frame Bracket by using the (2) previously removed hardware along the top of the Rear Frame Bracket, (2) 3/8"-16 x 2-3/4" HHCS (Item #2), (2) 3/8" Flat Washers (Item #3) and (2) 3/8"-16 Ny-Flange Lock Nuts (Item #4) along the bottom of the Rear Frame Bracket. See the Figure below.

Note: Some parts and part features have been hidden from view for visual clarity.

Figure A

Item #	Part #	Desc.	Qty.
1	B2073	Rear Frame Brkt.	1
2	K1021	3/8"-16 X 2-3/4" HHCS	2
3	K0047	Flat Washer 3/8" / 1.00 OD x .446 ID x .075 T	2
4	K2038	Ny-Flange Lock Nut 3/8"-16	2

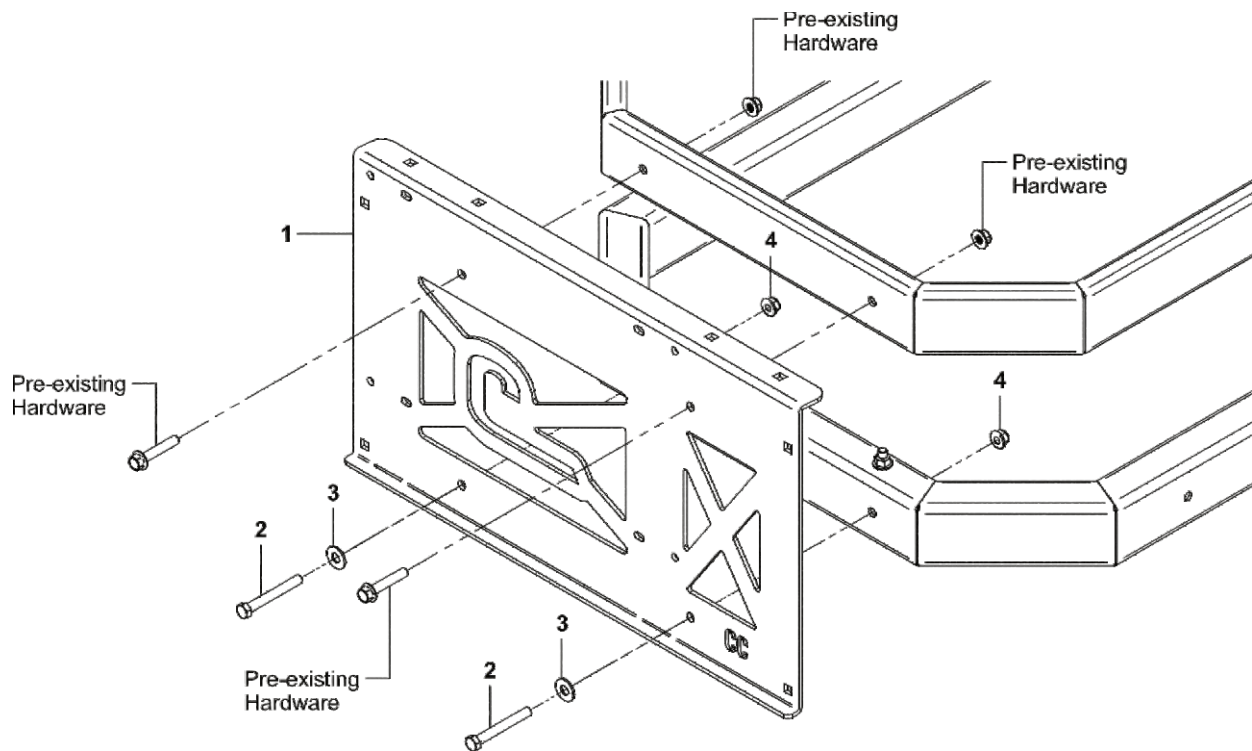

Rear Frame Bracket Installation (Cont.)

Before installing the Rear Frame Bracket (Item #2) for the MY2022 unit, a Frame Spacer (Item #1) would need to first be installed.

Position the Frame Spacer's (Item #1) mount holes to those on the Mower's rear frame, see Figure A below. Secure the Frame Spacer by using (2) 3/8"-16 x 2-3/4" HHCS (Item #3), (2) 3/8" Flat Washers (Item #4) and (2) 3/8"-16 Ny-Flange Lock Nuts (Item #5).

Once the Frame Spacer has been installed, align the mount holes of the Rear Frame Bracket (Item #2) to those on the Mower's rear frame, see Figure A below. Secure the Rear Frame Bracket by using the (2) sets of previously removed hardware along the top of the Rear Frame Bracket, (2) 3/8"-16 x 1" HHCS (Item #6), and (2) 3/8"-16 Ny-Flange Lock Nuts (Item #5) along the bottom of the Rear Frame Bracket.

Note: Some parts and part features have been hidden from view for visual clarity.

Figure A

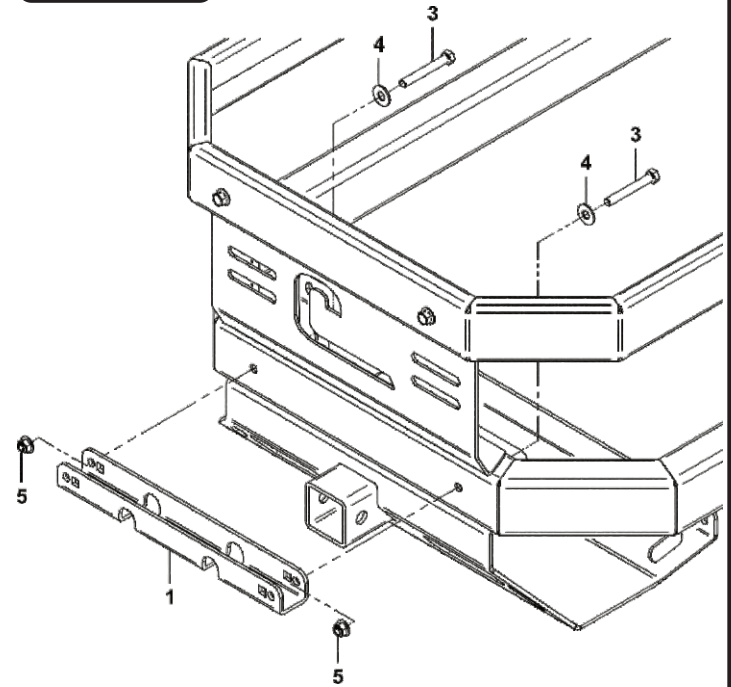

Item #	Part #	Desc.	Qty.
1	B2205	Frame Spacer / Boss XL 2020	1
2	B2073	Rear Frame Brkt.	1
3	K1021	3/8"-16 X 2-3/4" HHCS	2
4	K0047	Flat Washer 3/8" / 1.00 OD x .446 ID x .075 T	4
5	K2038	Ny-Flange Lock Nut 3/8"-16	4
6	K1191	HHCS 3/8"-16 x 1" GR5	2

Figure B

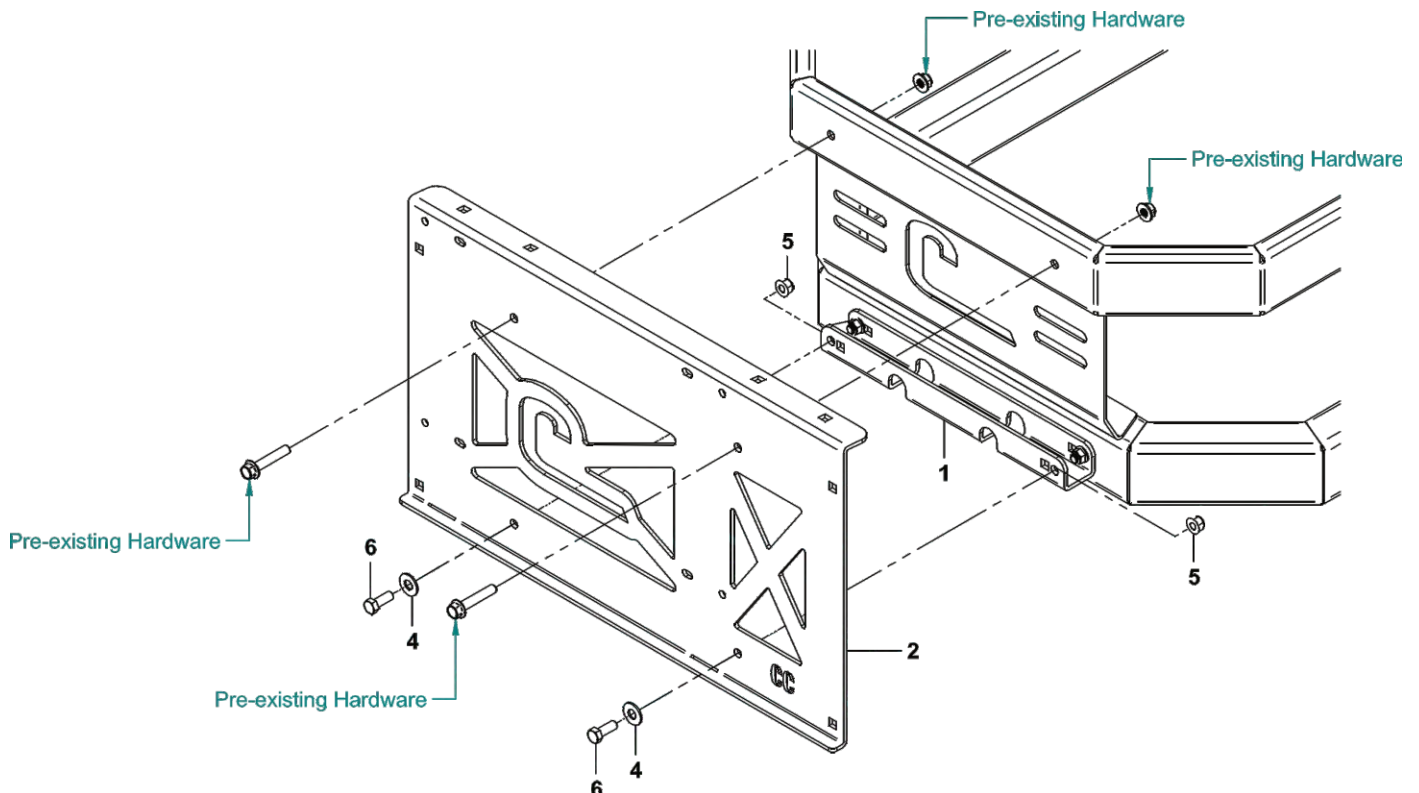

Side Frame Spacer Installation

MY2022

Before the Installation of the Left Frame Bracket P#(B2074) & Right Frame Bracket P#(B2075), pre install (1) Frame Spacer (Item #1) to each Bracket as shown in the Figures below.

To install the Frame Spacer (Item #1), align the bolt holes of the Frame Spacer to the side bolt holes of the Right Frame Bracket (Item #2) as shown in Figure A. Secure the Frame Spacer by using (2) 3/8"-16 x 1" Carriage Bolts (Item #3) and (2) 3/8"-16 Ny-Flange Lock Nuts (Item #4).

Repeat the steps for the Left Frame Bracket, see Figure B.

Note: Some parts and part features have been hidden from view for visual clarity.

Figure A

Item #	Part #	Desc.	Qty.
1	B2205	Frame Spacer / Boss XL 2020	1
2	B2075	Rt. Frame Brkt.	1
3	K1182	Carriage Bolt 3/8"-16 x 1"	2
4	K2038	Ny-Flange Lock Nut 3/8"-16	2

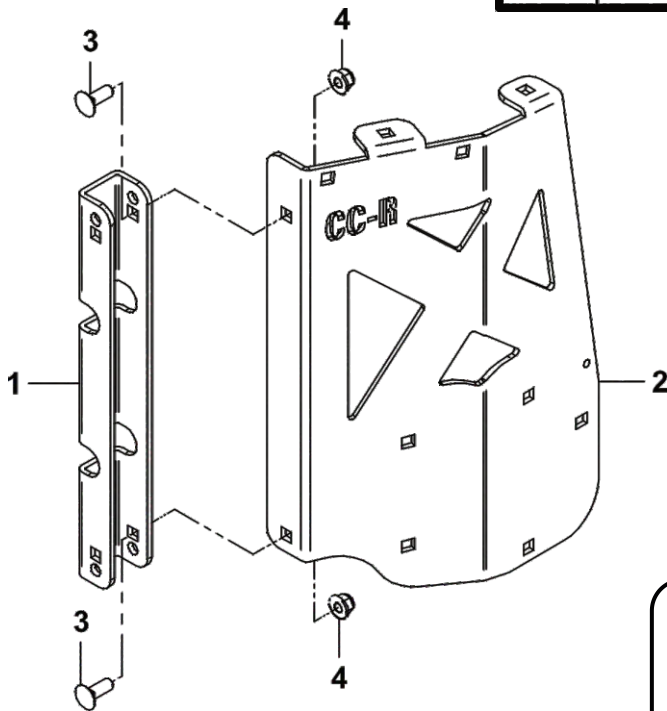
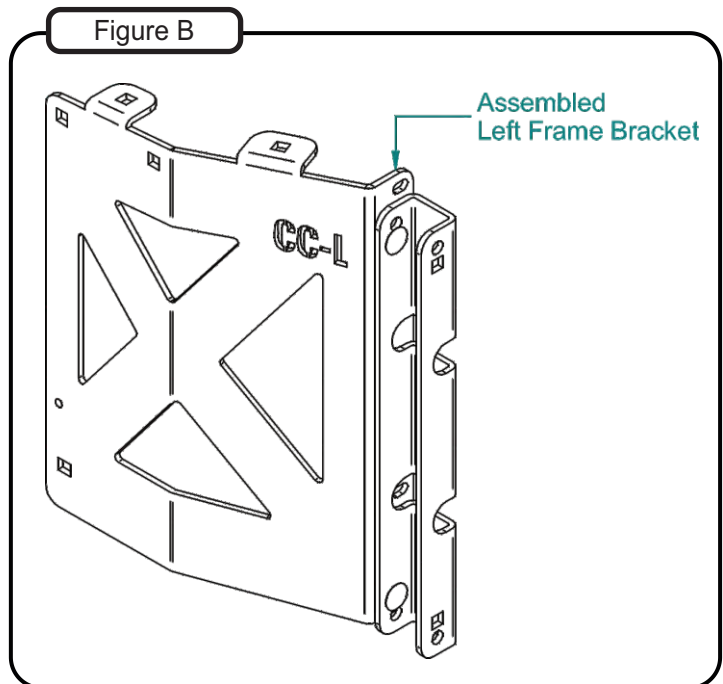

Figure B



Right & Left Frame Bracket Installation

MY2021

To install the Right Frame Bracket (Item #1) align and position the (2) mount holes located on the upright tab of the Right Frame Bracket (Item #1) to those located on the right side of the Rear Frame Bracket (Item #3). Secure the Right Frame Bracket, relatively loosely, by using (2) 3/8"-16 x 1" Carriage Bolt (Item #4) and (2) 3/8"-16 Ny-Flange Lock Nuts (Item #6). Refer to Figure A.

Once secured to the Rear Frame Bracket (Item #3), secure the Right Frame Bracket (Item #1) to the Mower by using (1) 3/8"-16 x 3" Carriage Bolt (Item #5) and (1) 3/8"-16 Ny-Flange Lock Nut (Item #6). See Figure B. Tighten All hardware at this time.

Repeat the same procedures for the installation of the Left Frame Bracket (Item #2), see Figure A.

Note: Some parts and part features have been hidden from view for visual clarity.

Figure A

Item #	Part #	Desc.	Qty.
1	B2075	Rt. Frame Brkt.	1
2	B2074	Lt. Frame Brkt.	1
3	B2073	Rear Frame Brkt.	2
4	K1182	Carriage Bolt 3/8"-16 x 1"	4
5	K1187	3/8"-16 x 3" Carriage Bolt	2
6	K2038	Ny-Flange Lock Nut 3/8"-16	6

Right Side View

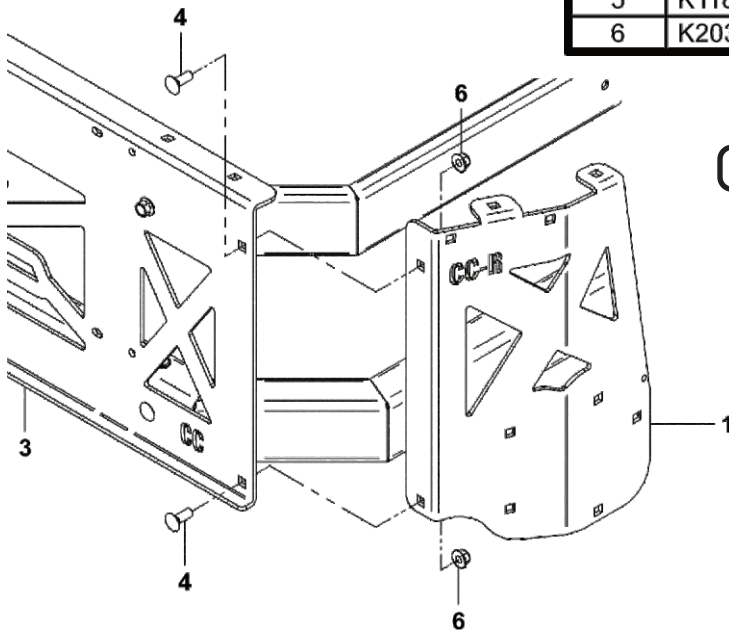
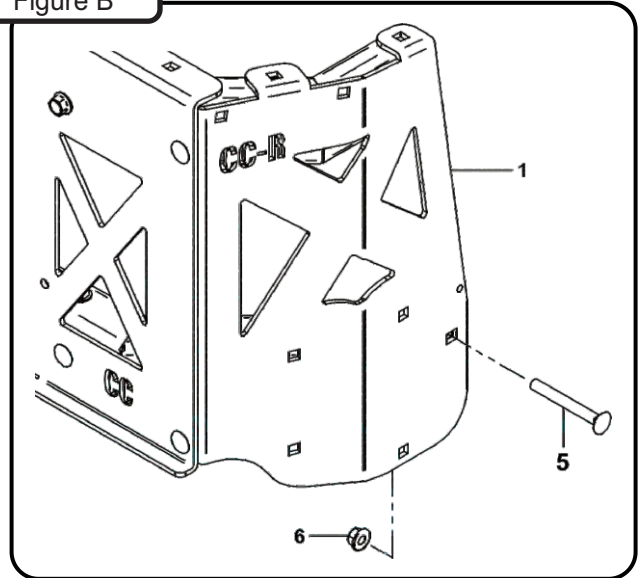
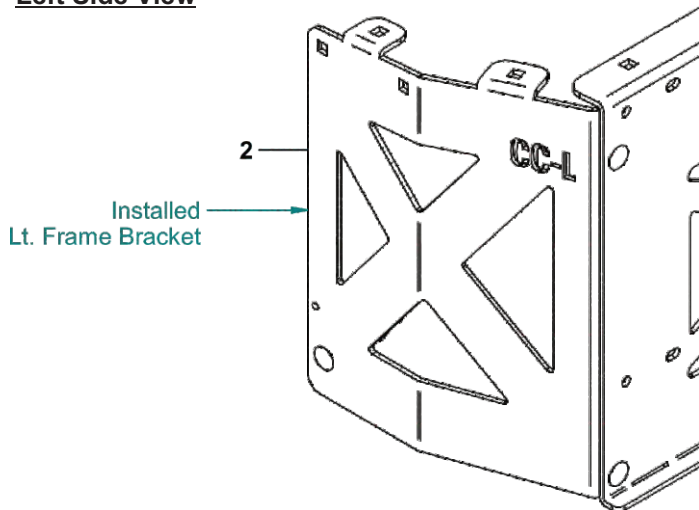

Figure B



Left Side View



Right & Left Frame Bracket Installation (Cont.)

MY2022

To install the pre-installed Right Frame Bracket (Item #1) from the previous step, align and position the (2) mount holes located on the Frame Spacer (Item #3) of the pre-installed Right Frame Bracket to those located on the right of the Rear Frame Bracket. Secure the Frame Spacer, relatively loosely, by using (2) 3/8"-16 x 1" Carriage Bolt (Item #4) and (2) 3/8"-16 Ny-Flange Lock Nuts (Item #6). Refer to Figure A.

Once secured to the Rear Frame Bracket, secure the Right Frame Bracket to the Mower by using (1) 3/8"-16 x 3" Carriage Bolt (Item #5) and (1) 3/8"-16 Ny-Flange Lock Nut (Item #6). See Figure B. Tighten All hardware at this time.

Repeat the same procedures for the installation of the pre-installed Left Frame Bracket (Item #2). See Figure A.

Note: Some parts and part features have been hidden from view for visual clarity.

Figure A

Item #	Part #	Desc.	Qty.
1	B2075	Rt. Frame Brkt.	1
2	B2074	Lt. Frame Brkt.	1
3	B2205	Frame Spacer / Boss XL 2020	1
4	K1182	Carriage Bolt 3/8"-16 x 1"	2
5	K1187	3/8"-16 x 3" Carriage Bolt	1
6	K2038	Ny-Flange Lock Nut 3/8"-16	3

Right Side View

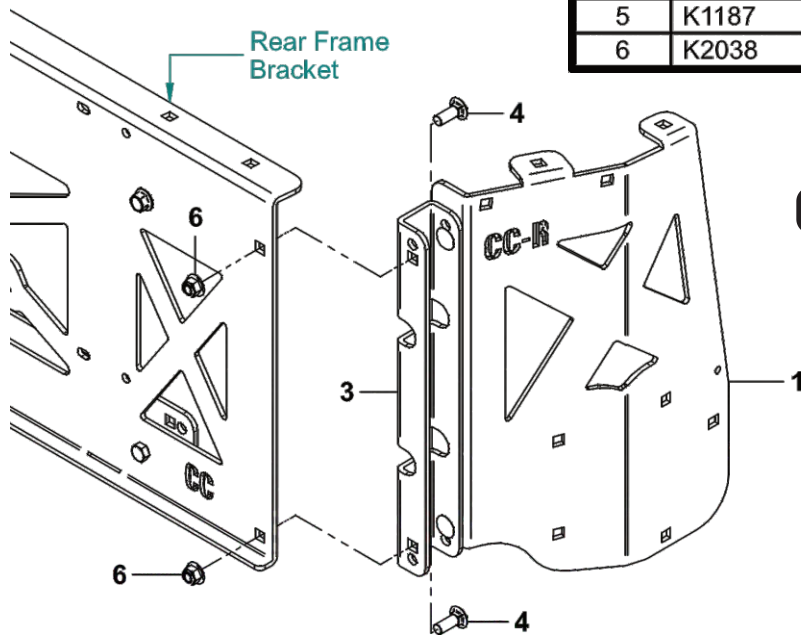
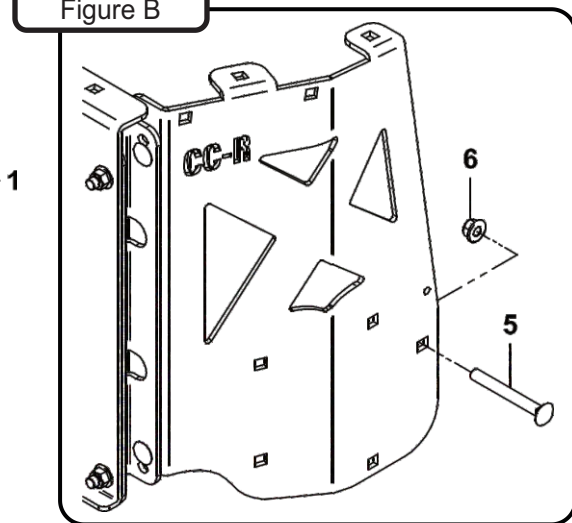
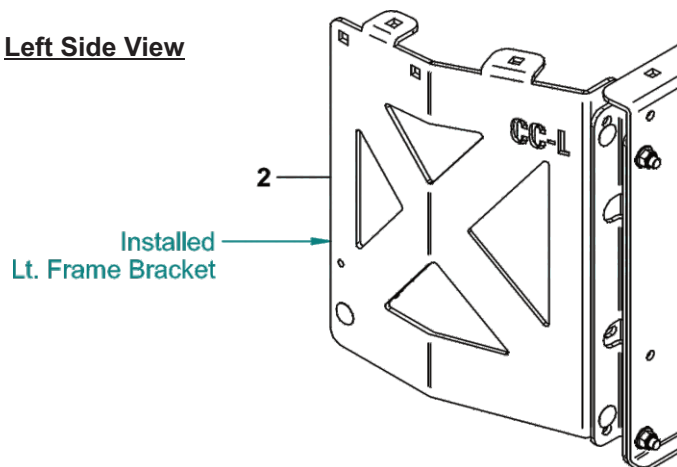

Figure B



Left Side View



Frame Gusset Installation

MY2021

Your Frame Gussets (Item #1) will have (2) different sets of bolt holes for your specific Mower model, see Figure B.

To install the Frame Gusset (Item #1) on the right side, align and position the mount holes of the Frame Gusset over the mount holes located on the top right of the Rear Frame Bracket and the top of the Right Frame Bracket. Secure the Frame Gusset, relatively loosely, by using (4) 3/8"-16 x 1" Carriage Bolt (Item #2) and (4) 3/8"-16 Ny-Flange Lock Nuts (Item #3). Refer Figure A below.

Repeat the same procedures to install the left side Frame Gusset. Once installed, tighten at this time.

Note: Some parts and part features have been hidden from view for visual clarity.

Figure A

Item #	Part #	Desc.	Qty.
1	B2081	Frame Gusset	1
2	K1182	Carriage Bolt 3/8"-16 x 1"	4
3	K2038	Ny-Flange Lock Nut 3/8"-16	4

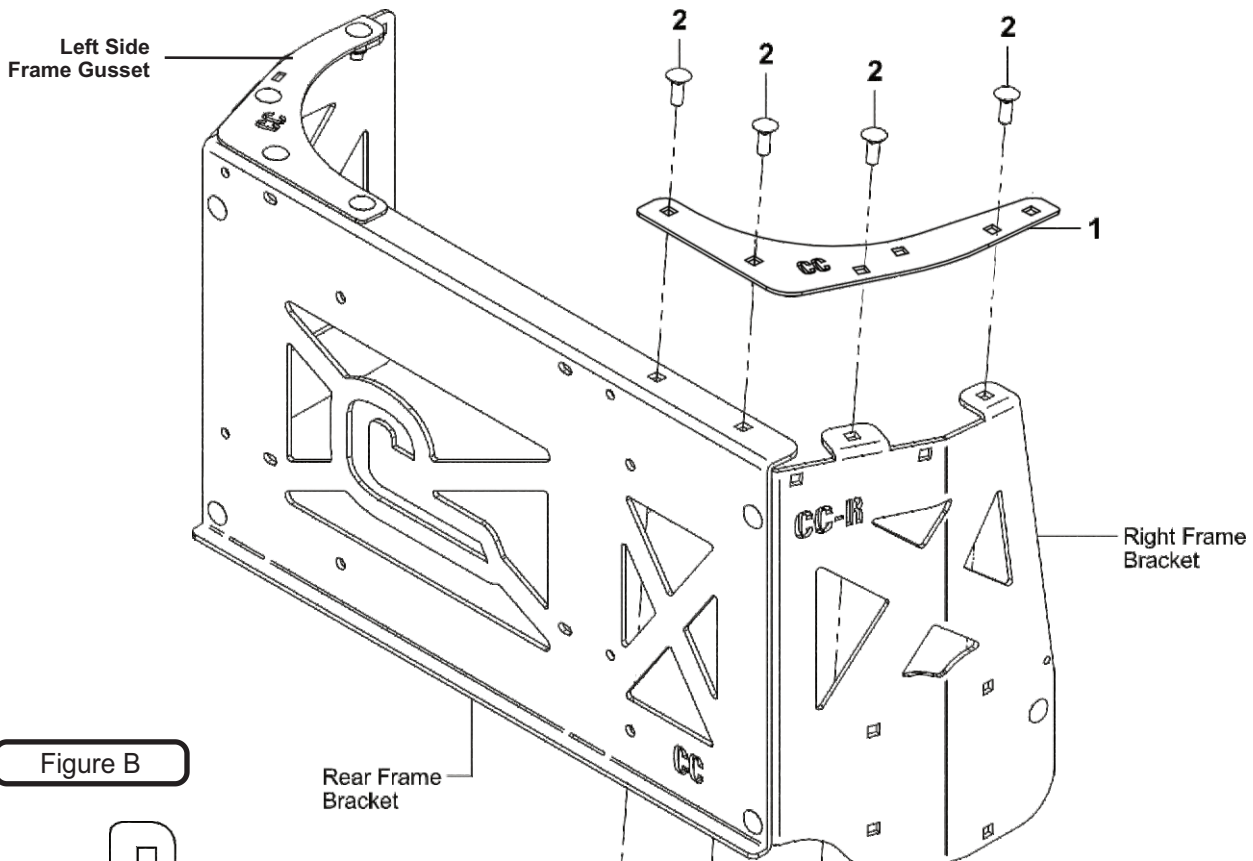
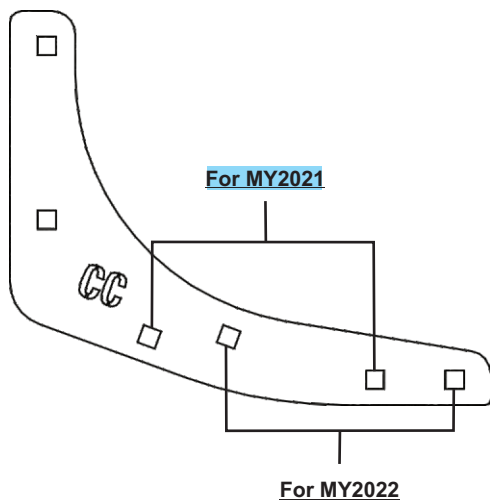

Figure B



Frame Gusset Installation (Cont.)

MY2022

Your Frame Gussets (Item #1) will have (2) different sets of bolt holes for your specific Mower model, see Figure B.

To install the Frame Gusset (Item #1) on the right side, align and position the mount holes of the Frame Gusset over the mount holes located on the top right of the Rear Frame Bracket and the top of the Right Frame Bracket. Secure the Frame Gusset, relatively loosely, by using (4) 3/8"-16 x 1" Carriage Bolt (Item #2), (2) 3/8" Flat Washers (Item #3) and (4) 3/8"-16 Ny-Flange Lock Nuts (Item #4). Refer Figure A below.

Repeat the same procedures to install the left side Frame Gusset. Once installed, tighten at this time.

Note: Some parts and part features have been hidden from view for visual clarity.

Figure A

Item #	Part #	Desc.	Qty.
1	B2081	Frame Gusset	2
2	K1182	Carriage Bolt 3/8"-16 x 1"	4
3	K1477	Flat Washer / 3/8" / .406 ID x .812 OD x .125 Thk	4
4	K2038	Ny-Flange Lock Nut 3/8"-16	4

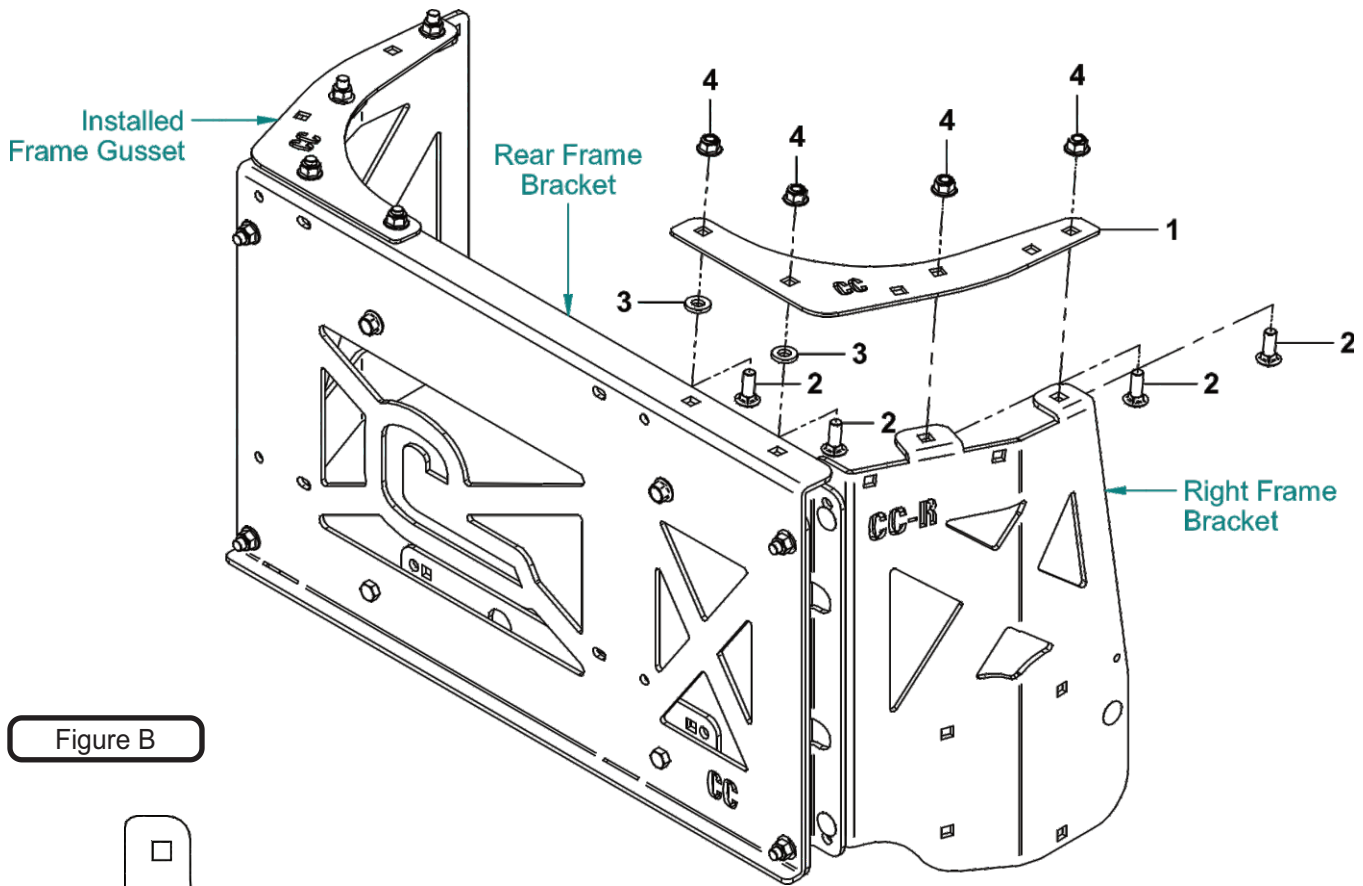
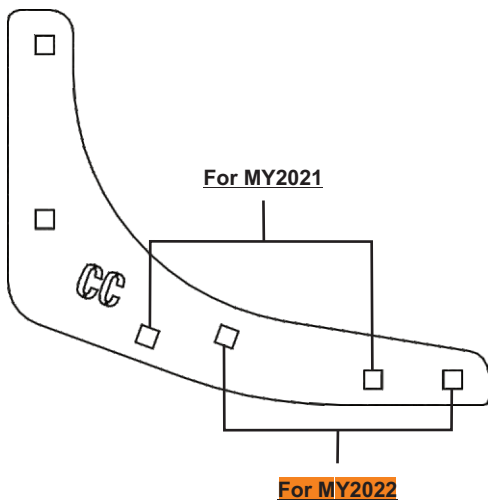

Figure B



Mount Arm / Top Bracket Installation

To install the Mount Arm / Top Bracket (Item #1) align the bolt holes to those on Right Frame Bracket. Secure the Mount Arm / Top Bracket, relatively loose, by using (2) 3/8"-16 x 1" Carriage Bolts (Item #2) and (2) 3/8"-16 Ny-Flange Lock Nuts (Item #3). Refer to Figure A.

Keep the hardware relatively loose until after the installation of the Mount Arm / Gusset.

Note: Some parts and part features have been hidden from view for visual clarity.

Figure A

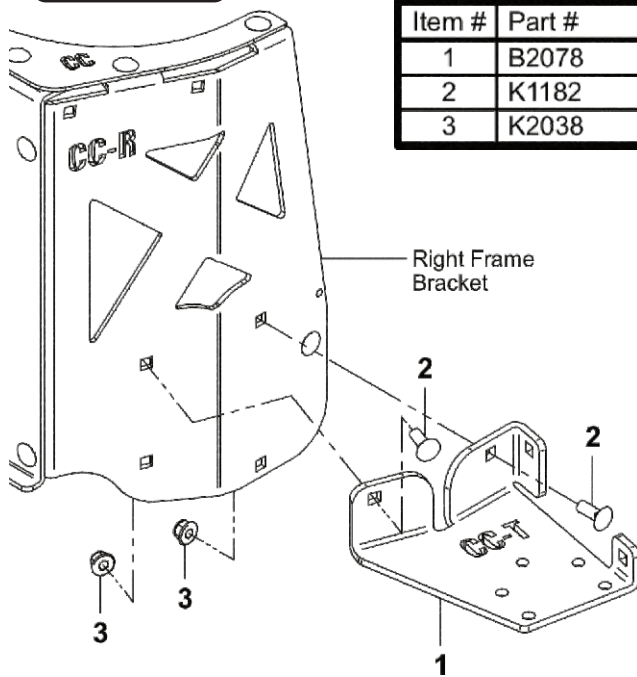

Item #	Part #	Desc.	Qty.
1	B2078	Mount Arm / Top Brkt.	1
2	K1182	Carriage Bolt 3/8"-16 x 1"	2
3	K2038	Ny-Flange Lock Nut 3/8"-16	2

Mount Arm / Bottom Bracket Installation

To install the Mount Arm / Bottom Bracket (Item #1) align the bolt holes to those on Right Frame Bracket. Secure the Mount Arm / Bottom Bracket, relatively loose, by using (2) 3/8"-16 x 1" Carriage Bolts (Item #2) and (2) 3/8"-16 Ny-Flange Lock Nuts (Item #3). Refer to Figure B.

Keep the hardware relatively loose until after the installation of the Mount Arm / Gusset.

Note: Some parts and part features have been hidden from view for visual clarity.

Figure B

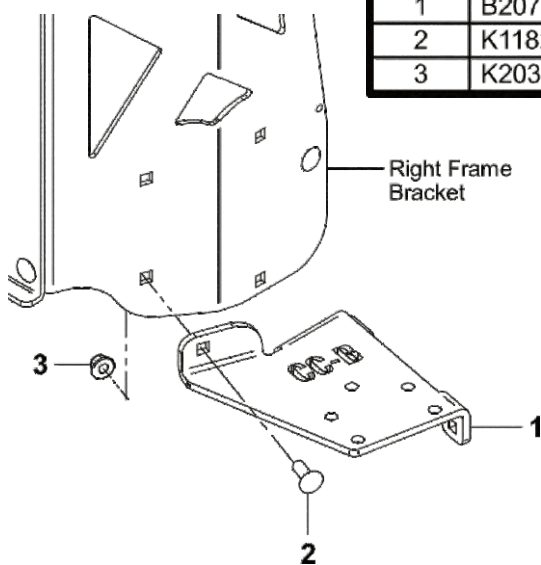

Item #	Part #	Desc.	Qty.
1	B2079	Mount Arm / Bottom Brkt.	1
2	K1182	Carriage Bolt 3/8"-16 x 1"	2
3	K2038	Ny-Flange Lock Nut 3/8"-16	2

Lower Side View

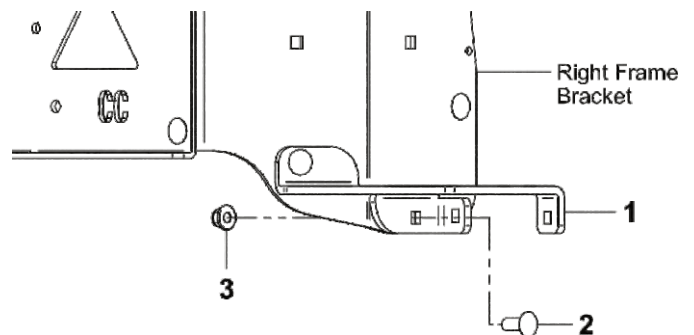

Mount Arm / Gusset Installation

After the installation of the Top (Item #4) and Bottom (Item #5) Mount Arm Brackets align the Mount Arm / Gusset (Item #1) mount holes to those located on the side of both Top and Bottom Mount Arm Brackets, refer to Figure B. Secure the Mount Arm / Gusset by using (4) 3/8"-16 x 1" Carriage Bolts (Item #2) and (4) 3/8"-16 Ny-Flange Lock Nuts (Item #3). Refer to Figure A.

Tighten all hardware at this time.

Note: Some parts and part features have been hidden from view for visual clarity.

Figure A

Item #	Part #	Desc.	Qty.
1	B2080	Mount Arm / Gusset	1
2	K1182	Carriage Bolt 3/8"-16 x 1"	4
3	K2038	Ny-Flange Lock Nut 3/8"-16	4
4	B2078	Mount Arm / Top Brkt.	1
5	B2079	Mount Arm / Bottom Brkt.	1

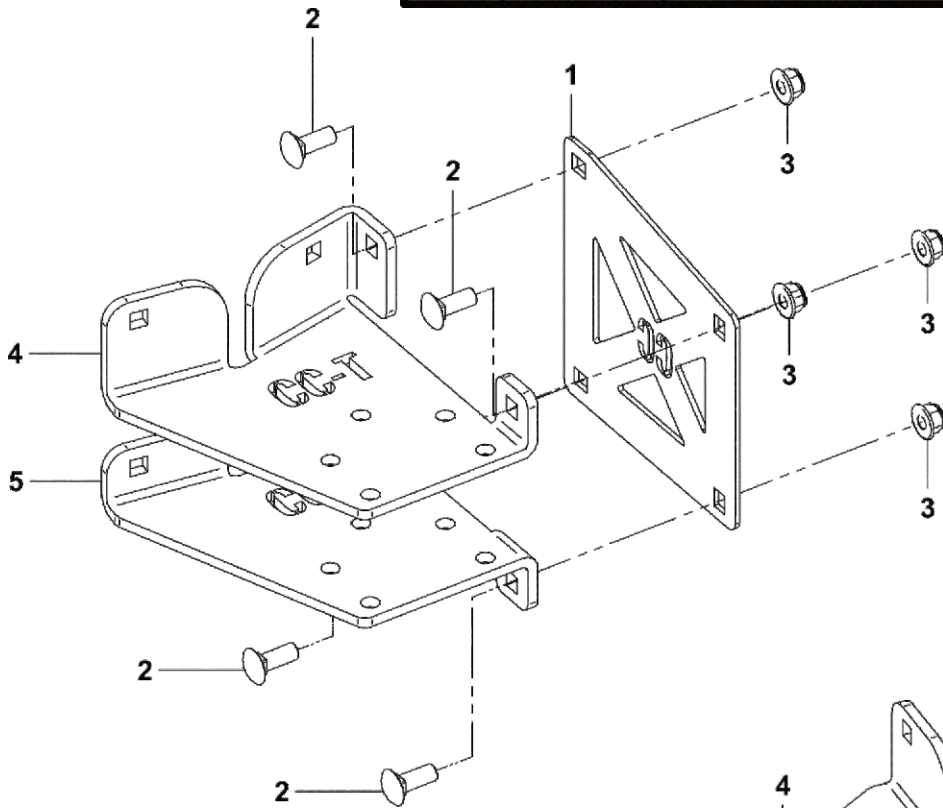
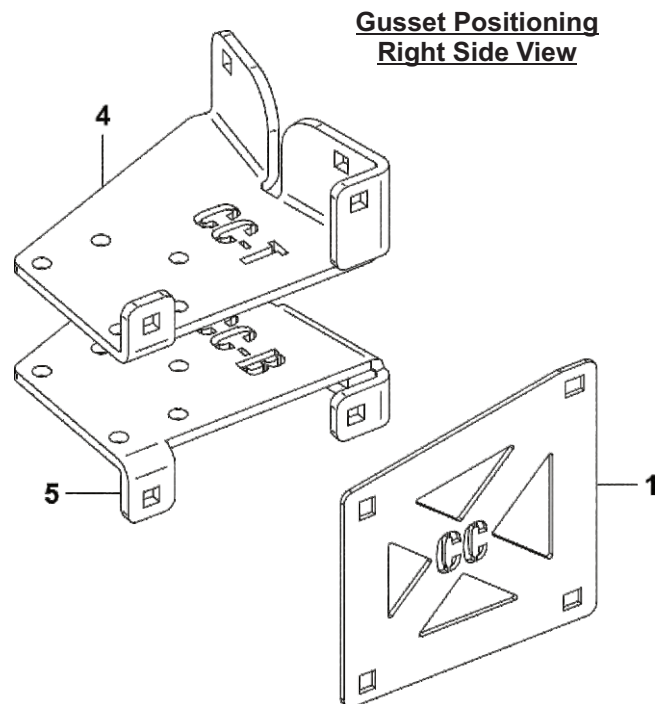

Figure B



Mount Arm / Tube Assembly Installation

First, use (1) 3/8"-16 x 3-1/2" HHCS (Item #2) and (1) 3/8"-16 Ny-Flange Lock Nut (Item #3) to install a stop bolt between both the Top / Mount Arm (Item #4) and Bottom / Mount Arm (Item #5). See Figure A. This will help with the installation of the Mount Arm / Receiver Tube Assy (Item #1).

Insert the Receiver Tube Assy (Item #1) in between the Top & Bottom Mount Arms using the Stop Bolt previously installed as a stopping point. Position the Receiver Tube between the (2) sets of bolt holes on the left and right side. Secure the Receiver Tube Assy by using (4) 3/8"-16 x 3-1/2" HHCS (Item #2) and (4) 3/8"-16 Ny-Flange Lock Nuts (Item #3), refer to Figure B.

Note: Some parts and part features have been hidden from view for visual clarity.

Figure A

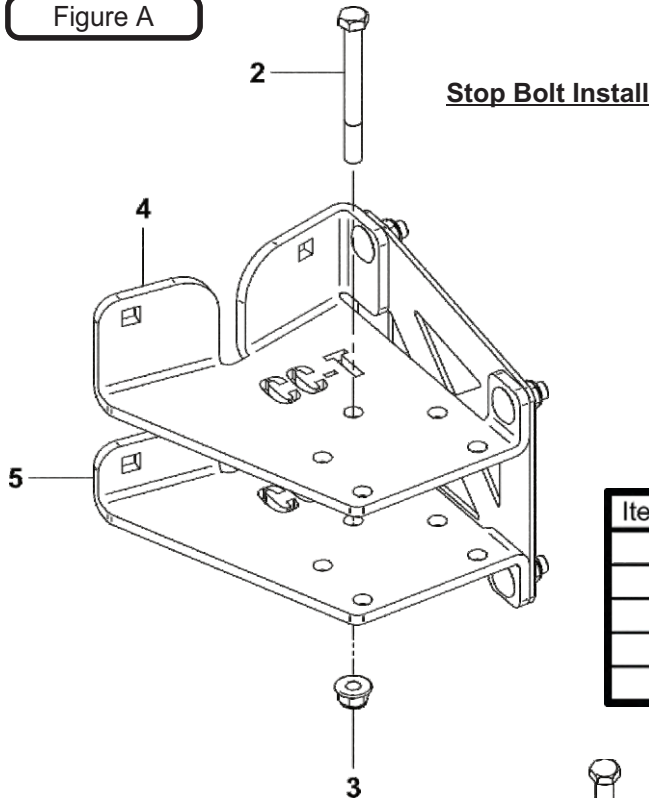

Item #	Part #	Desc.	Qty.
1	A2207	Receiver Tube Assy. / Mount Arm	1
2	K1200	3/8"-16 x 3.5" HHCS G5	4
3	K2038	Ny-Flange Lock Nut 3/8"-16	4
4	B2078	Mount Arm / Top Brkt.	1
5	B2079	Mount Arm / Bottom Brkt.	1

Figure B

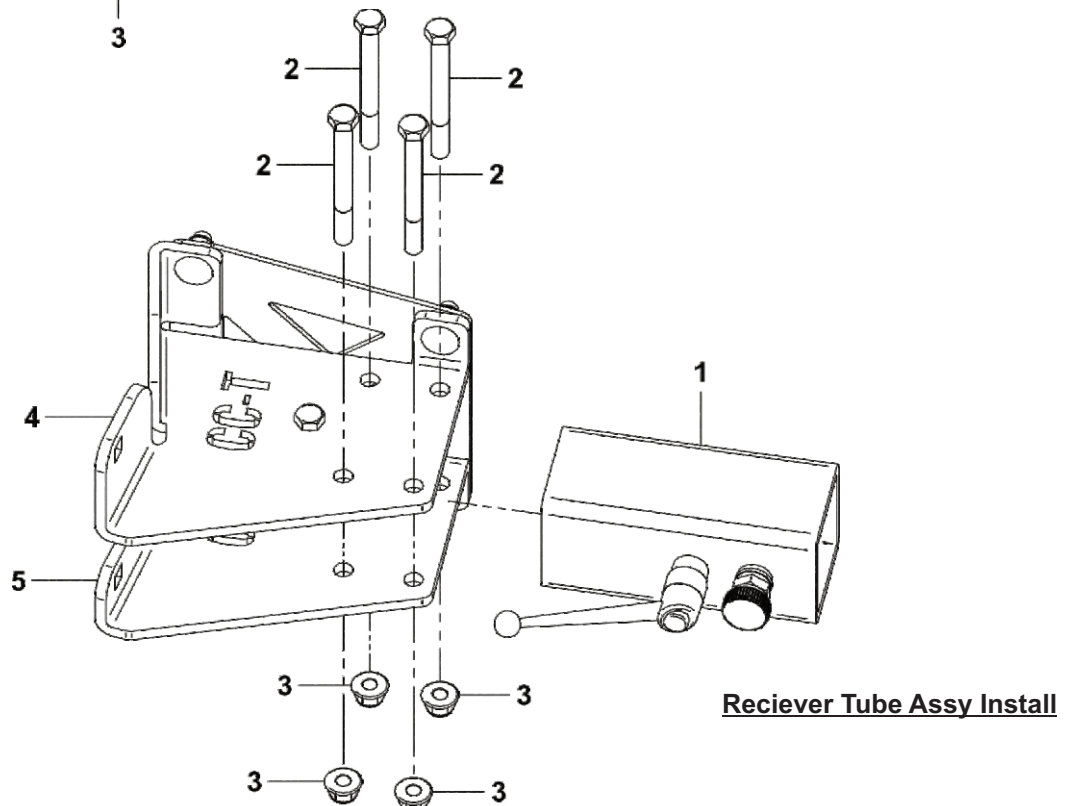

Lower Mount Tube Installation

Secure (2) Lower Mount Tubes (Item #1) to the Rear Lower Frame Bracket using (2) 5/16"-18 x 2" x 2-1/2" U-Bolt (Item #2) and (4) 5/16"-18 Ny-Flange Locknuts (Item #3) PER TUBE. Allow the Lower Mount Tubes to rest on the lower tab of the Rear Frame Bracket. Refer to Figure A.

Note: Some parts and part features have been hidden from view for visual clarity.

Figure A

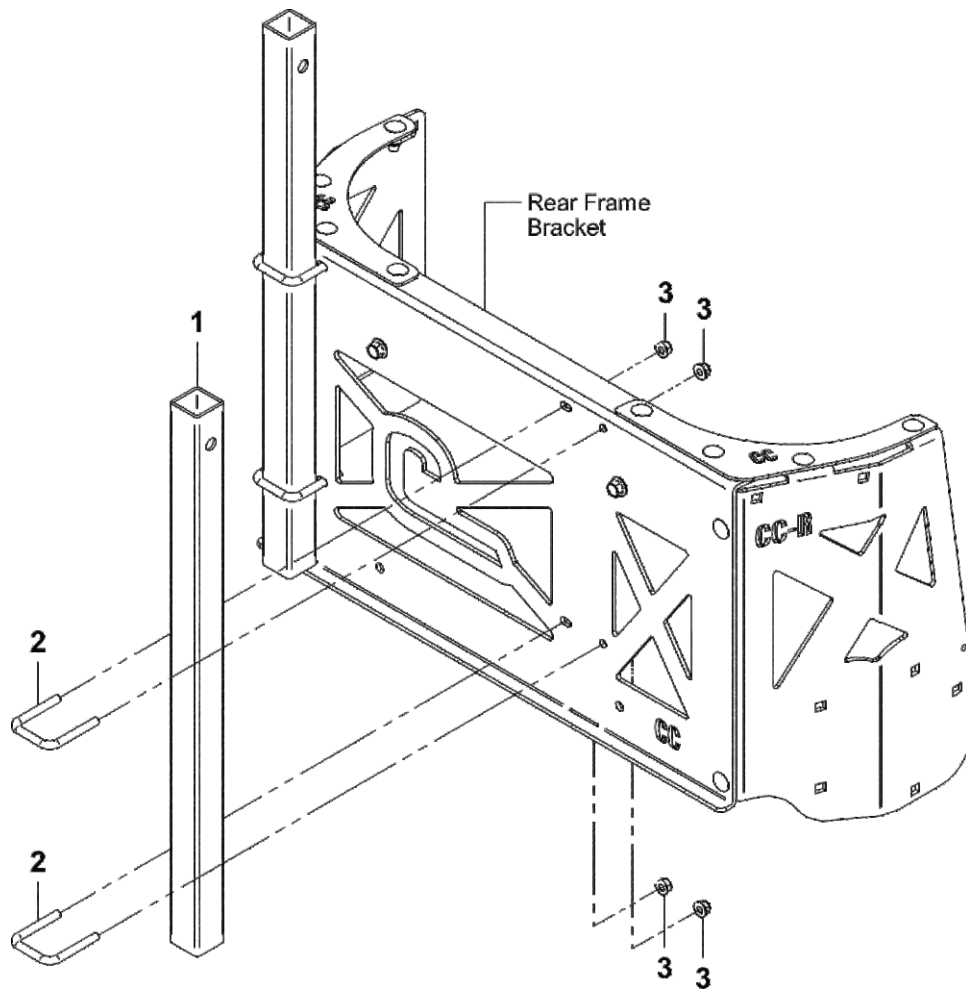

Item #	Part #	Desc.	Qty.
1	B0752	Lower Mount Tube / 25"	1
2	K1098	U-Bolt / 5/16"-18 x 2-3/8" x 1-3/4"	2
3	K2516	Ny-Flange Lock Nut 5/16"-18	4

Upper Frame Assembly Installation

Position the Upper Frame Assembly (Item #1) above the Lower Mount Tubes as shown in Figure A.

Slide the Upper Frame Assembly down onto the Lower Mount Tubes and secure using (2) Clevis Pins (Item #2) and (2) Rue Ring Cotter Pin Clips (Item #3). Refer to Figure B.

Note: Some parts and part features have been hidden from view for visual clarity.

Figure A

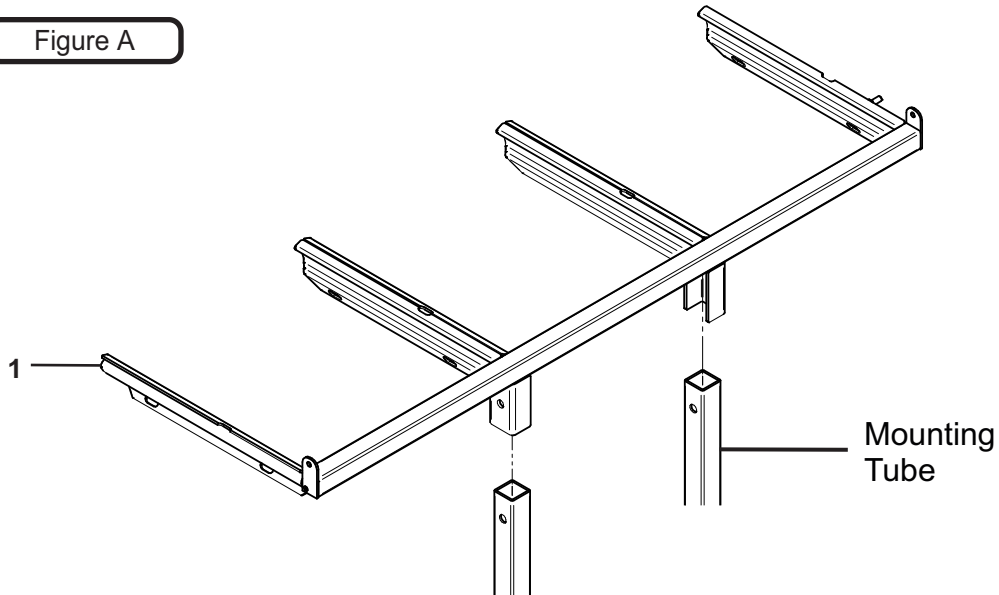

Item #	Part #	Desc.	Qty.
1	A2068	Upper Frame Assembly P3B Generic Gen 2	1
2	K0133	Clevis Pin 1/2" x 2-1/2"	2
3	K1437	Rue Ring Cotter Pin	2

Figure B

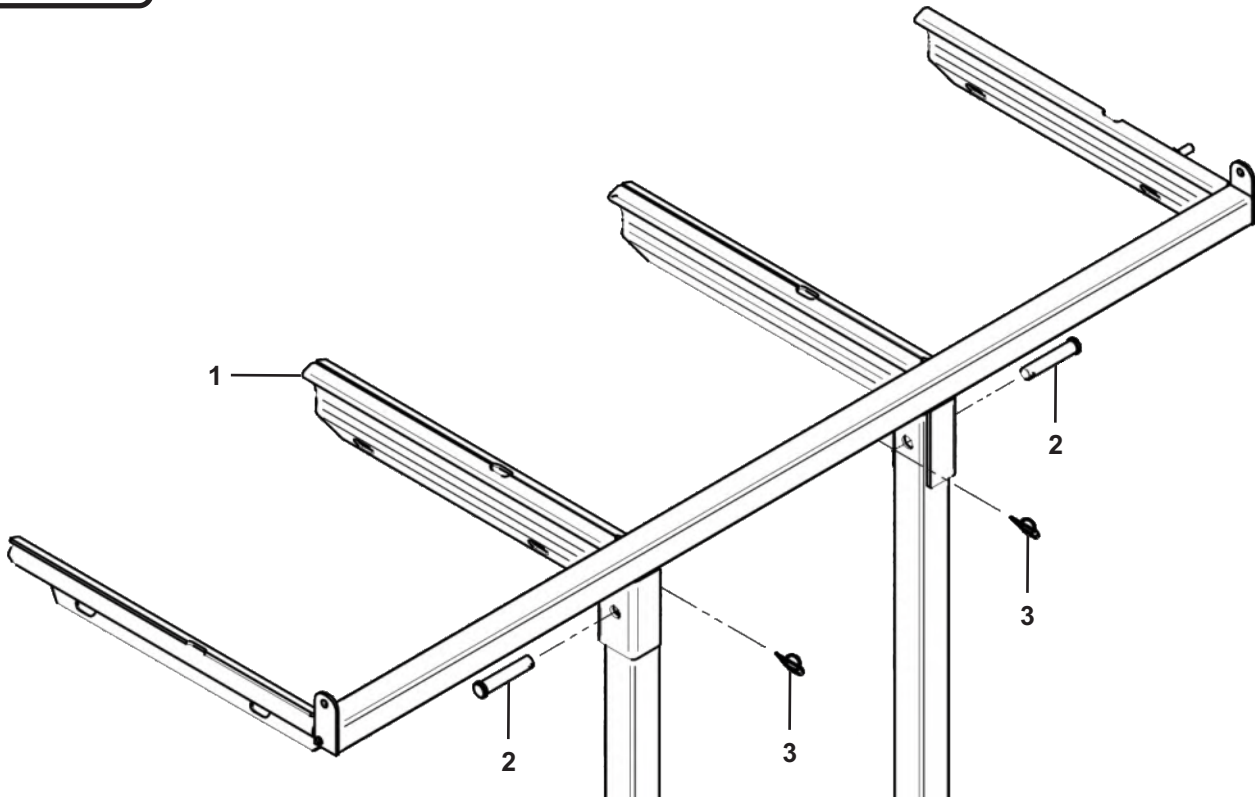

PTO Drive Assembly

Once the Mount Arm Assembly is installed and secured to the mower, assemble the Drive Assembly P#(A2061_02), Belt Guard Assembly P#(A2069_02) & Idler Mount Assembly P#(A2067_02).

First, attach the Belt Guard Assembly P#(A2069_02) to the Drive Assembly P#(A2061_03) using (2) 1/4"-20 x 5/8" Carriage Bolts P#(K1010) and (2) 1/4"-20 Ny-Flange Lock Nuts P#(K2014). Refer to Figure A. **Leave Bolts Loose.**

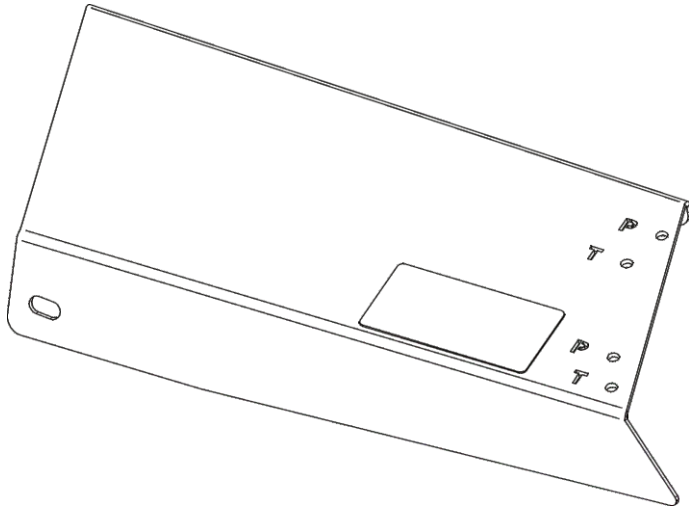

BELT GUARD ASSY. HOLES

Notice Marked Holes Below;
For This Installation, Use Holes
Marked With The Letter 'P'

Figure A

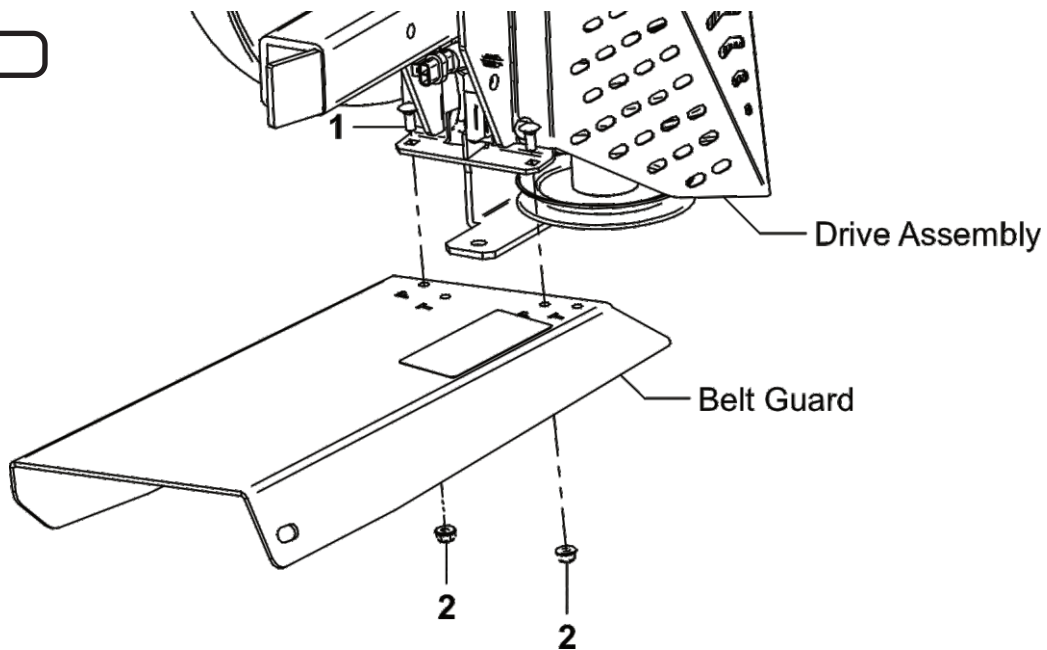

Item #	Part #	Desc.	Qty.
1	K1010	1/4"-20 x 5/8" Carriage Bolt	2
2	K2014	1/4"-20 Ny-Flange Lock Nut	2

PTO Drive Assembly (Continued)

Attach the Idler Mount Assembly P#(A2067_02) to the Drive Assembly using (1) 3/8"-16 x 1" HHCS (A) (Item #1), (1) 3/8"-16 x 1" Carriage Bolt (B) (Item #2) and (2) 3/8"-16 Ny-Flange Lock Nuts (Item #3). Refer to Figure B.

Leave Bolts Loose (Note: Orientation of bolts A & B.)

Next, secure the Idler Mount Assembly P#(A2067_02) to the Belt Guard Assembly P#(A2069_02) using (2) 3/8"-16 x 1" Carriage Bolts (Item #2) and (2) 3/8"-16 Ny-Flange Lock Nuts (Item #3). Refer to Figures C & D. Tighten All Bolts.

Figure B

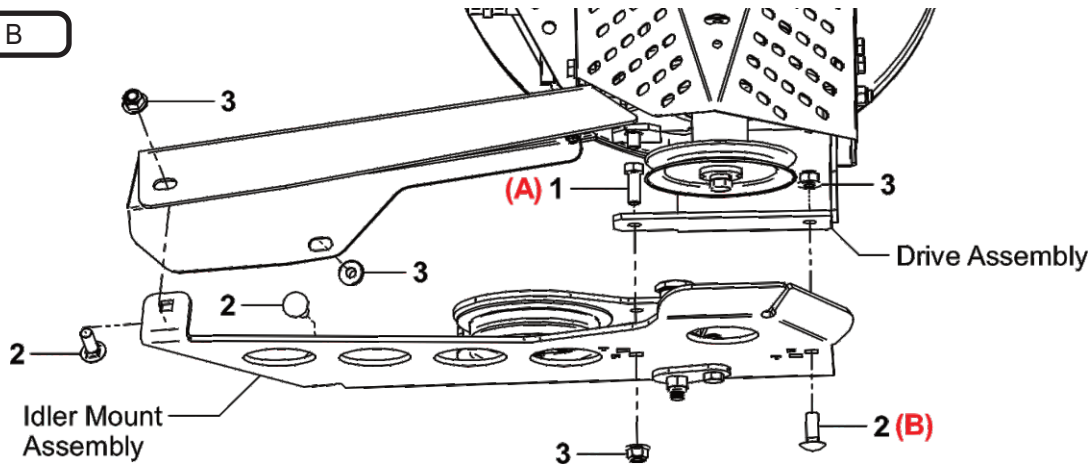

Item #	Part #	Desc.	Qty.
1	K1191	HHCS 3/8"-16 x 1" GR5	1
2	K1182	Carriage Bolt 3/8"-16 x 1"	3
3	K2038	Ny-Flange Lock Nut 3/8"-16	4

Figure C

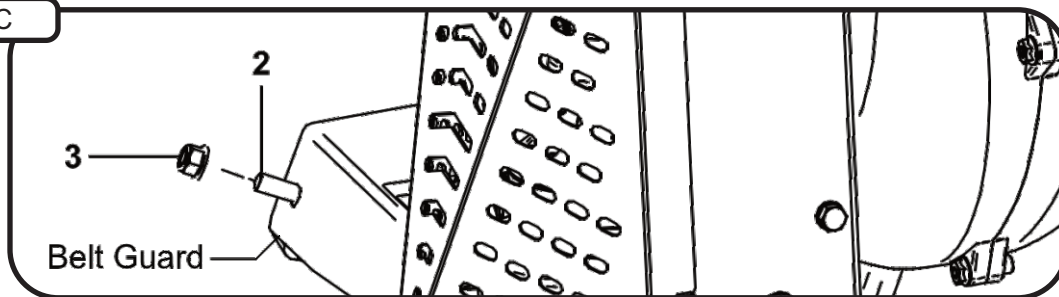
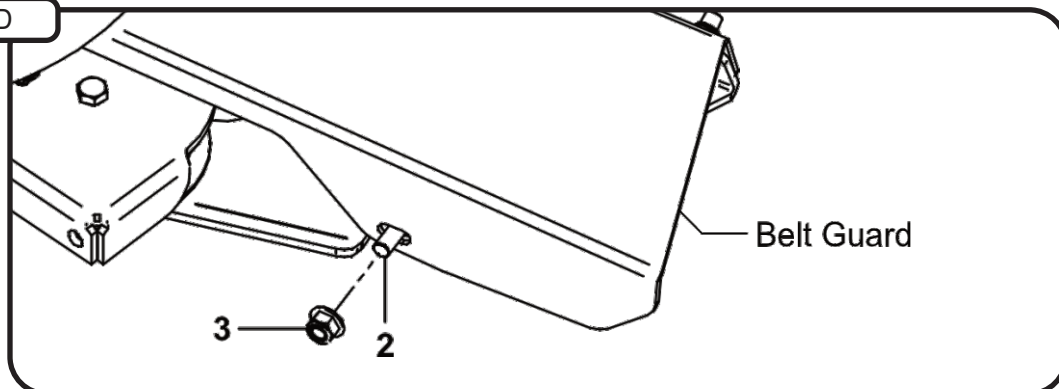

Figure D



Drive Assembly and Belt Installation

Note: It is recommended that someone assist during this step.

Insert the Drive Assembly into the receiver tube on the Mount Arm Assembly until the Knob Plunger Pin engages. Once in place, turn Lock Handle clockwise until tight. Next, feed the Ak81 Belt P#(M0316) between the Belt Guard and the Idler Mount Assembly. Place belt around the Engine Drive Pulley on the underside of the mower. While one person inserts a screw driver (or similar tool) into the Idler Mount Assembly and rotates lever arm clockwise, enough to relieve all tension from belt, place belt around the Drive Assembly Pulley. Once the belt is in position, carefully release the tension to tighten belt.

Refer to the images below.

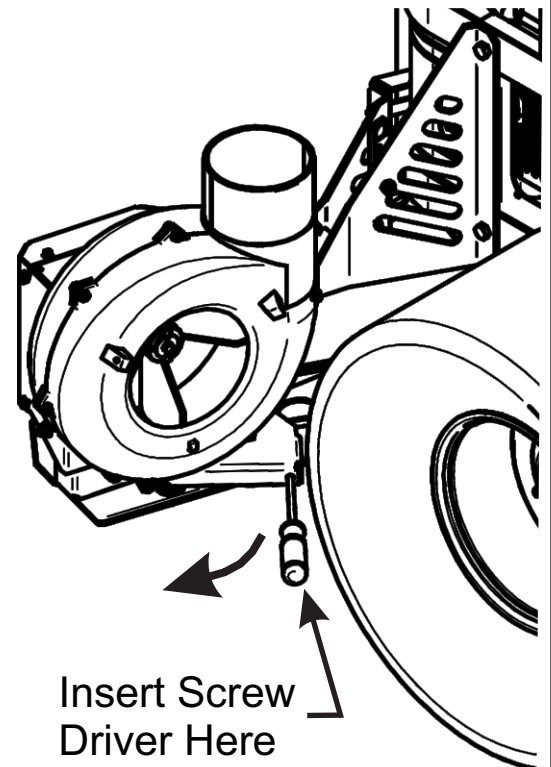
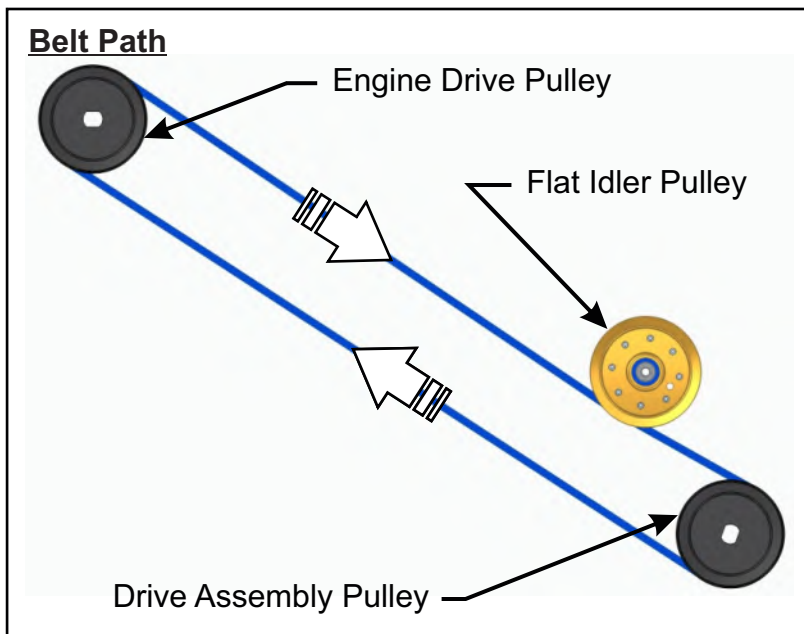
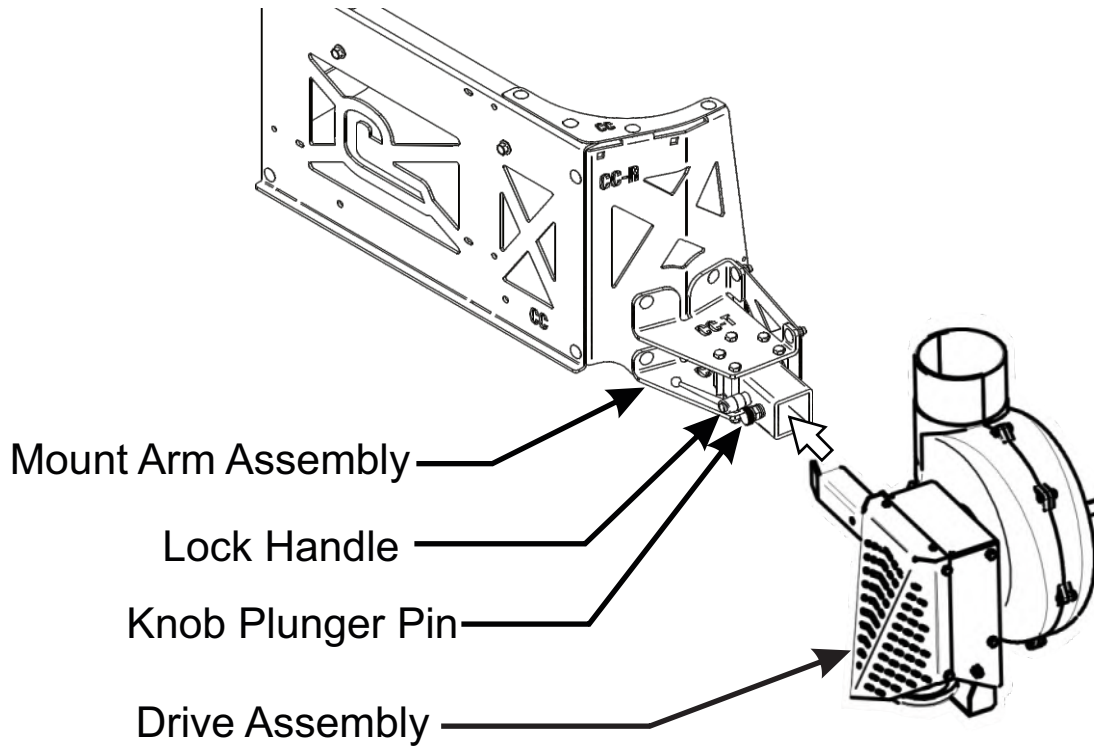

Belt Tension Adjustment

The following information provides you a step by step guide on how to position the PTO-X Drive to obtain proper belt tension before use. Failure to set proper belt tension can result in drive damage and frequent belt replacements.

In order to properly tension your belt you will need the following tools:

- Impact Wrench
- 9/16" Socket
- 9/16" Open-End Wrench
- 7/16" Open-End Wrench
- Gates Tension Gauge (See Figure A)
- Tape Measure
- Marking Pen

Figure A

Gates Tension Gauge



Step 1 - Remove the top belt guard from the drive assembly. See Figure B.

Figure B

Top Belt Guard

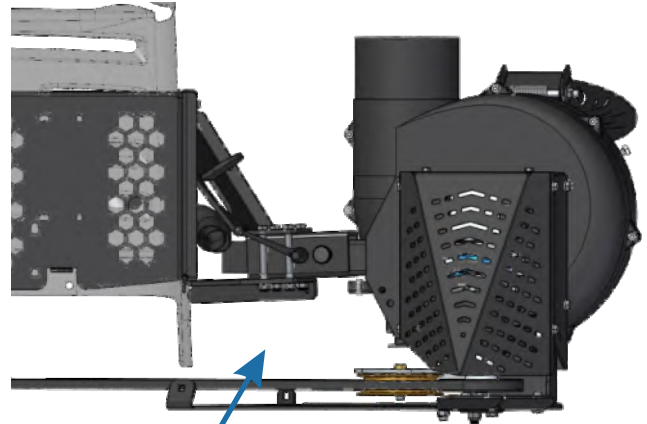

Belt Guard Removed

Step 2 - Using a measuring tape, measure from the pulley center to approximately 16" and lightly mark a line on the belt using a marking pen. See Figure C.

Figure C

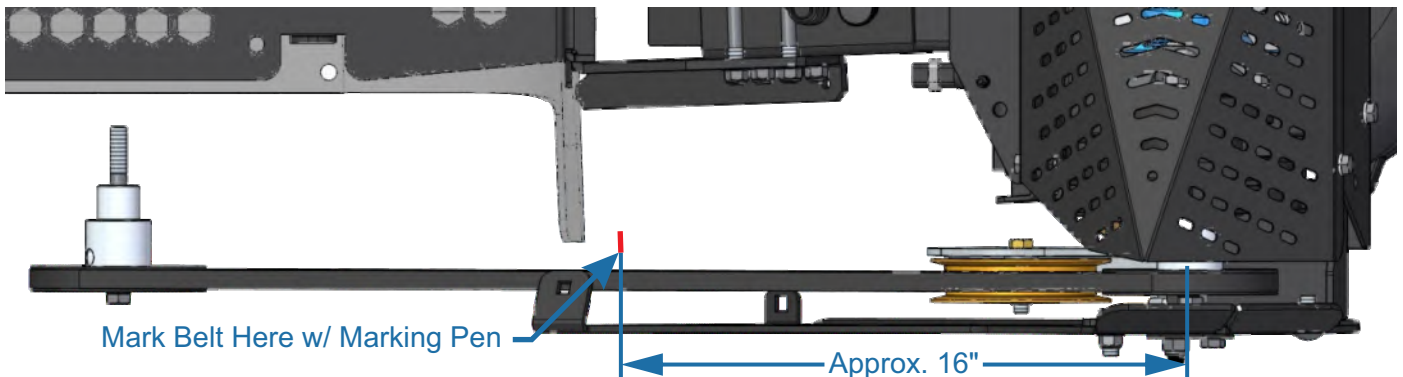

Belt Tension Adjustment (Cont.)

Step 3 - Place index finger into the loop on the Gates tension gauge. Position your finger over the line marked previously and keep the lower lip of the gauge below the belt. See Figure D.

Press inward until you feel a click. Remove the gauge and see the next step on how to determine the reading.

Figure D



Step 4 - To determine the tension, position the gauge at an angle to see where the edge of the blue dial intersects with the gauge markings. In Figure E below, the gauge is reading approximately 35 lbs. of tension.

The proper belt tension should measure between 35 lbs. minimum and 40 lbs. maximum. If your reading is within this range, you can replace the top belt guard and forego the next steps.

Figure E

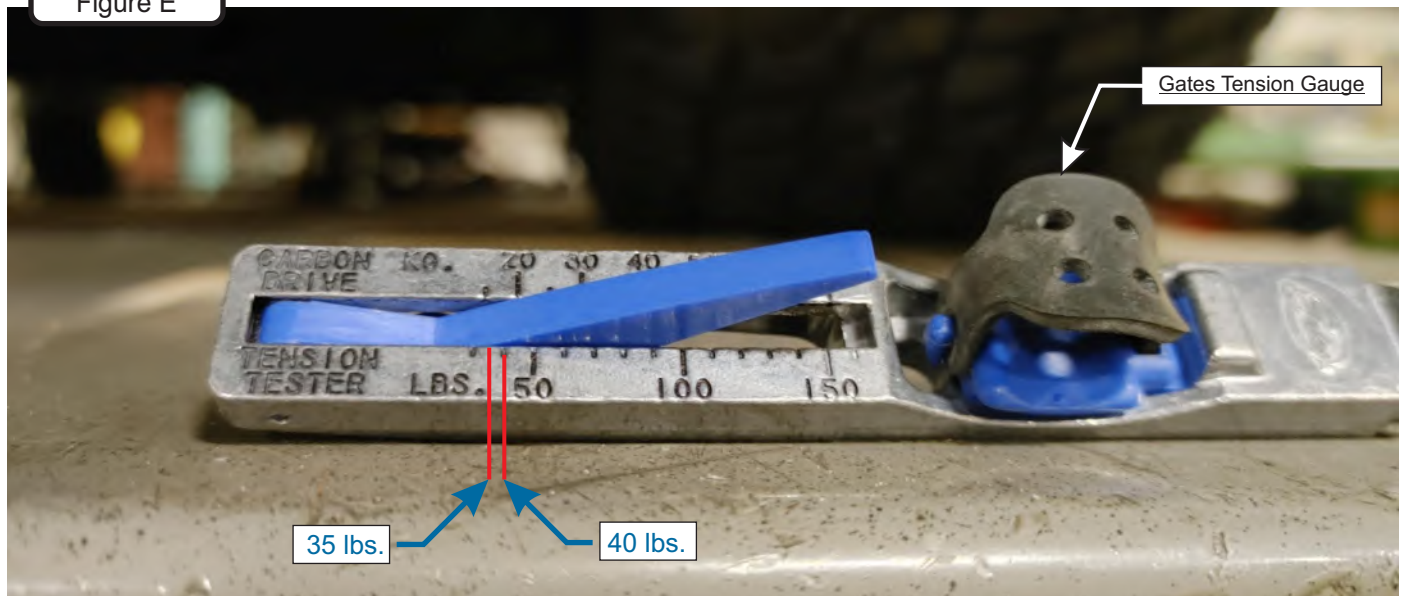

Belt Tension Adjustment (Cont.)

Step 5 - Belt Tension Procedure To Achieve 35-40 lbs. Tension

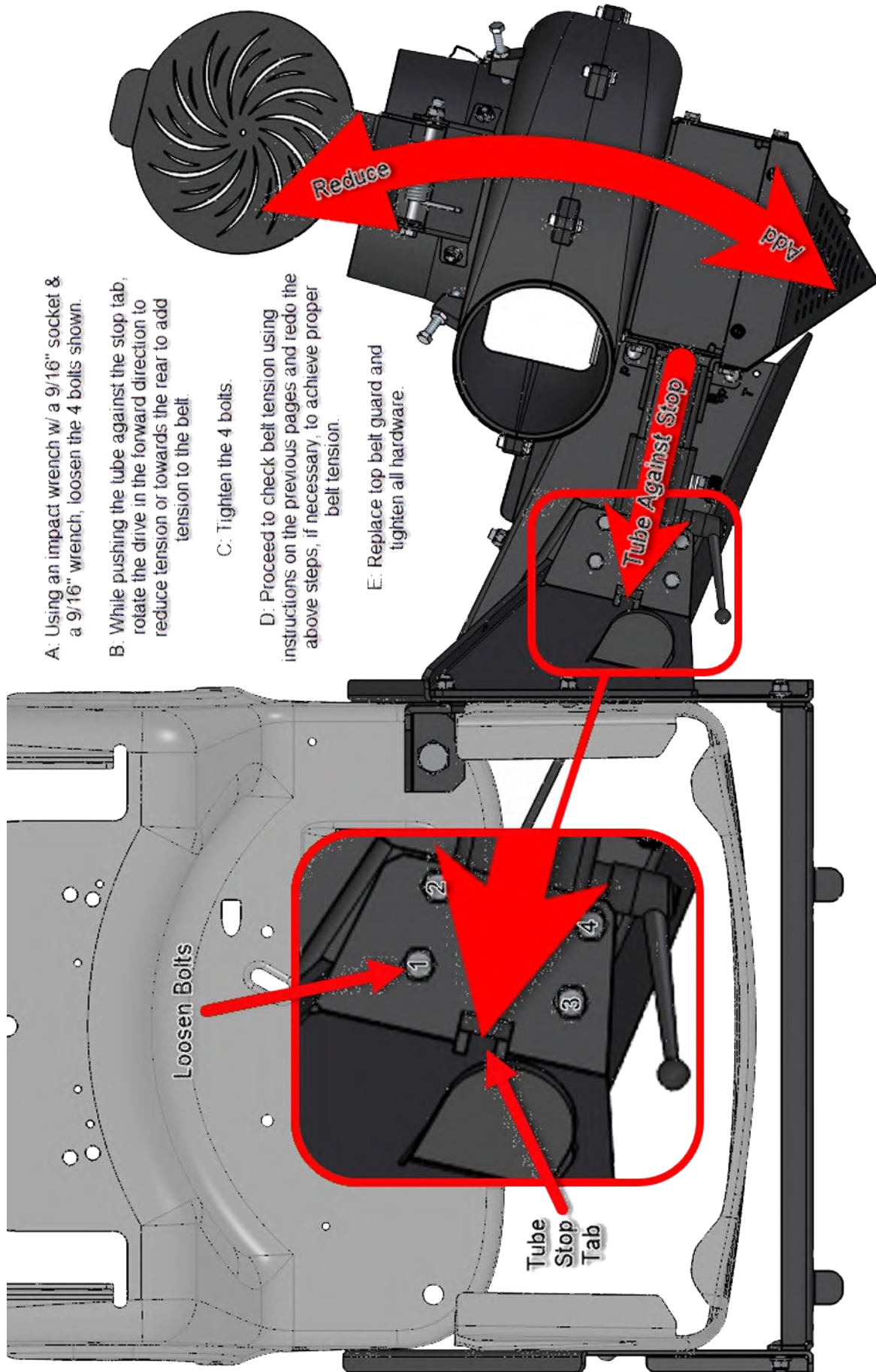

A: Using an impact wrench w/ a 9/16" socket & a 9/16" wrench, loosen the 4 bolts shown.

B: While pushing the tube against the stop tab, rotate the drive in the forward direction to reduce tension or towards the rear to add tension to the belt.

C: Tighten the 4 bolts.

D: Proceed to check belt tension using instructions on the previous pages and redo the above steps, if necessary, to achieve proper belt tension.

E: Replace top belt guard and tighten all hardware.

Top Assembly To Upper Frame Assembly Installation

Align the Top Assembly Pivot Holes to the Upper Frame Assembly. See Figure A below. Before fastening, pull Rubber Dust Guard outward to seal against Upper Frame Assembly (towards the mower's operator seat). Fasten the Top Assembly to the Upper Frame Assembly using (2) 5/16"-18 x 2-1/2" HHCS P#(K0125) and (2) 5/16"-18 Ny-Flange Locknuts P#(K2516). Leave the Ny-Flange Locknuts slightly loose to allow the Top Assembly to open and close easily.

Figure A

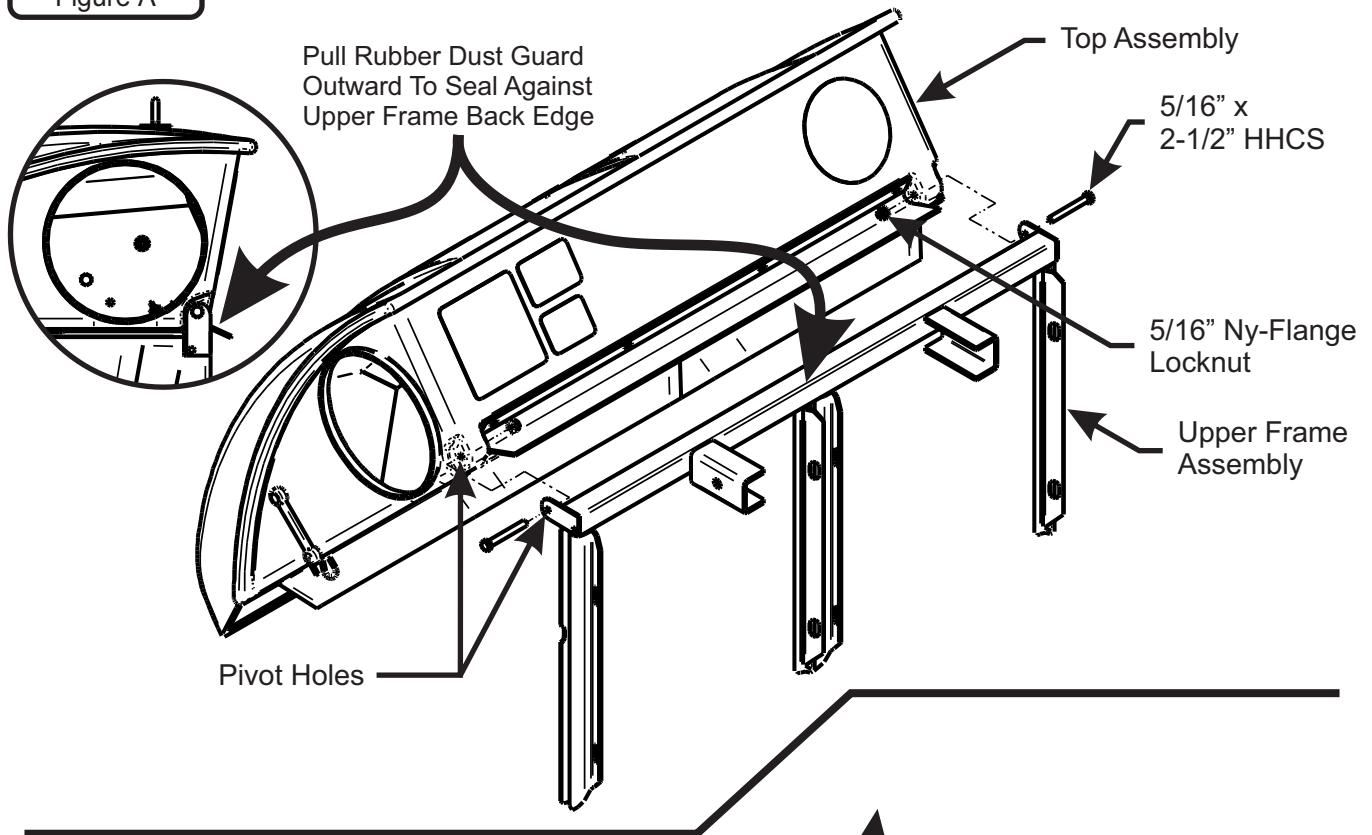

Inlet Installation

Position the Top Assembly on its side with the Inlet Hole facing up. See Figure B. 1: Insert the Inlet from inside the Top Assembly, up through the Inlet Hole, until the Inlet Retaining Lip meets the Inlet Hole. 2: Position the Inlet as shown in Figure B, then pull the Inlet until a portion of the Inlet Retaining Lip protrudes from the Inlet hole. 3: Next, lift the Inlet as shown in Figure B until all of the Inlet Retaining Lip protrudes from the Inlet Hole. Once installed, the Inlet should pivot freely about the Inlet Hole.

Figure B

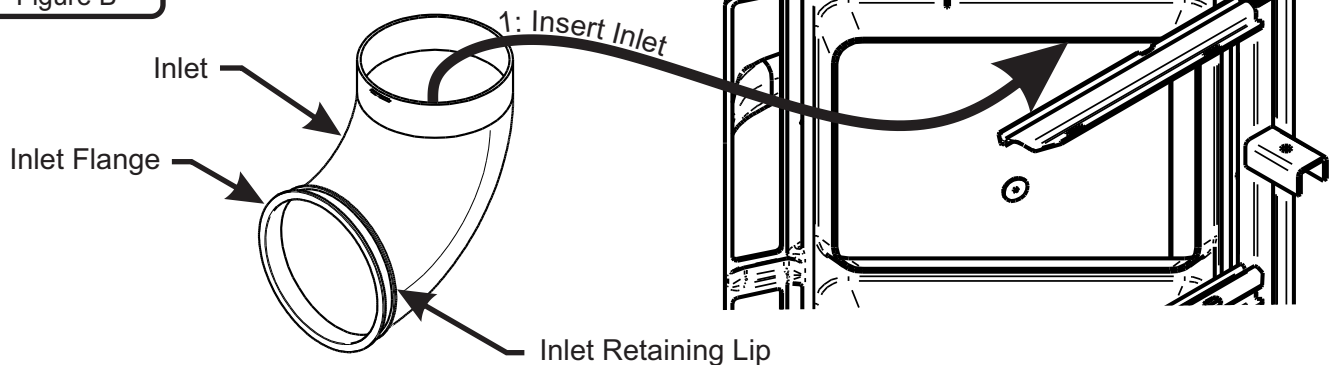

Hinge Kit Assembly Installation

Assemble the Hinge Kit using (1) Latch Plate P#(B0884), (1) 5/16"-18 x 1-1/4" HHCS P#(K1156), (1) 5/16"-18 Ny-Flange Lock Nut P#(K2516), (3) 5/16" Flat Washers P#(K0042), (1) Latch Spacer P#(S0006), (2) Extra Heavy 5/16" Fender Washers P#(K0505) and (1) 5/16"-18 Lock Nut P#(K0506). Leave the nuts loose enough to allow fluid movement of the top when opening and closing. When opened, the top should rest in the Latch Plate Slot.

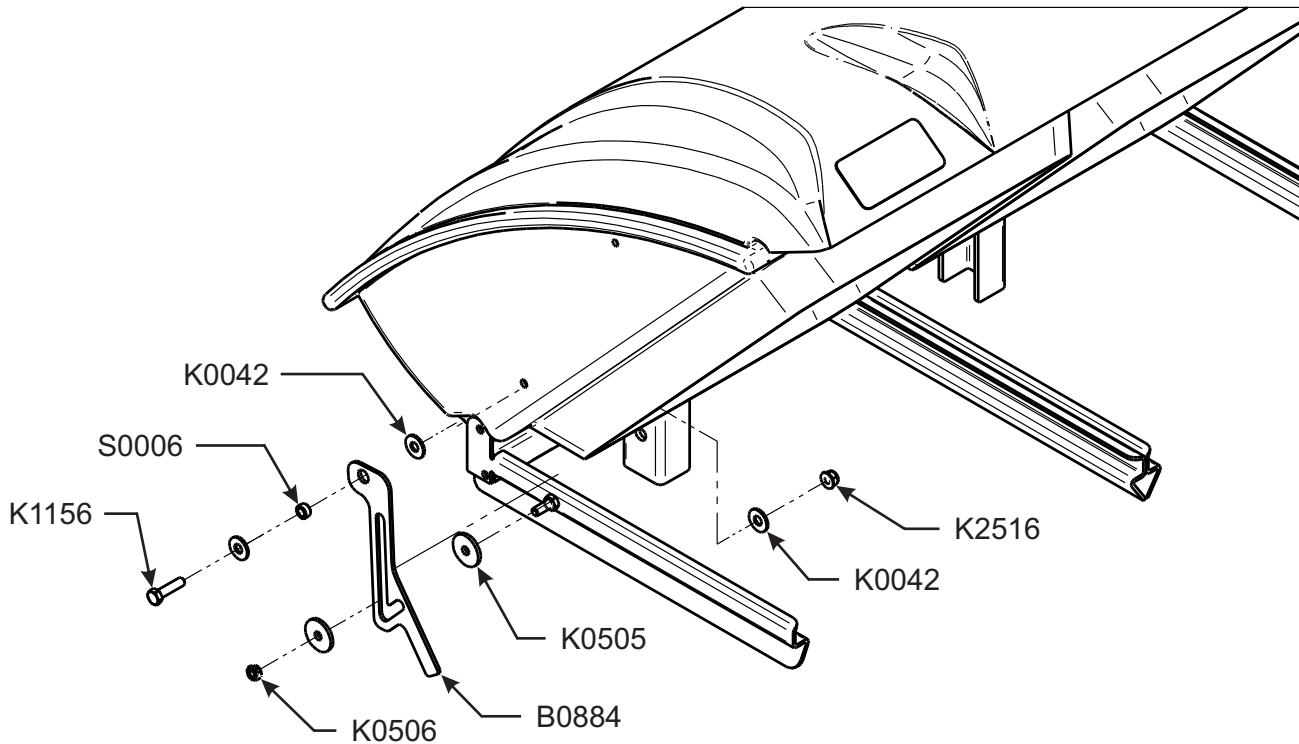

Even Bag Fill Adjustment

Flap can be adjusted Up/Down depending on mowing conditions. Adjust flap up to allow more dense material to reach left bag. Adjust flap down to allow less dense material to reach the right bag. Once adjusted properly, both bags should fill evenly, but may require further adjusting when mowing conditions change.

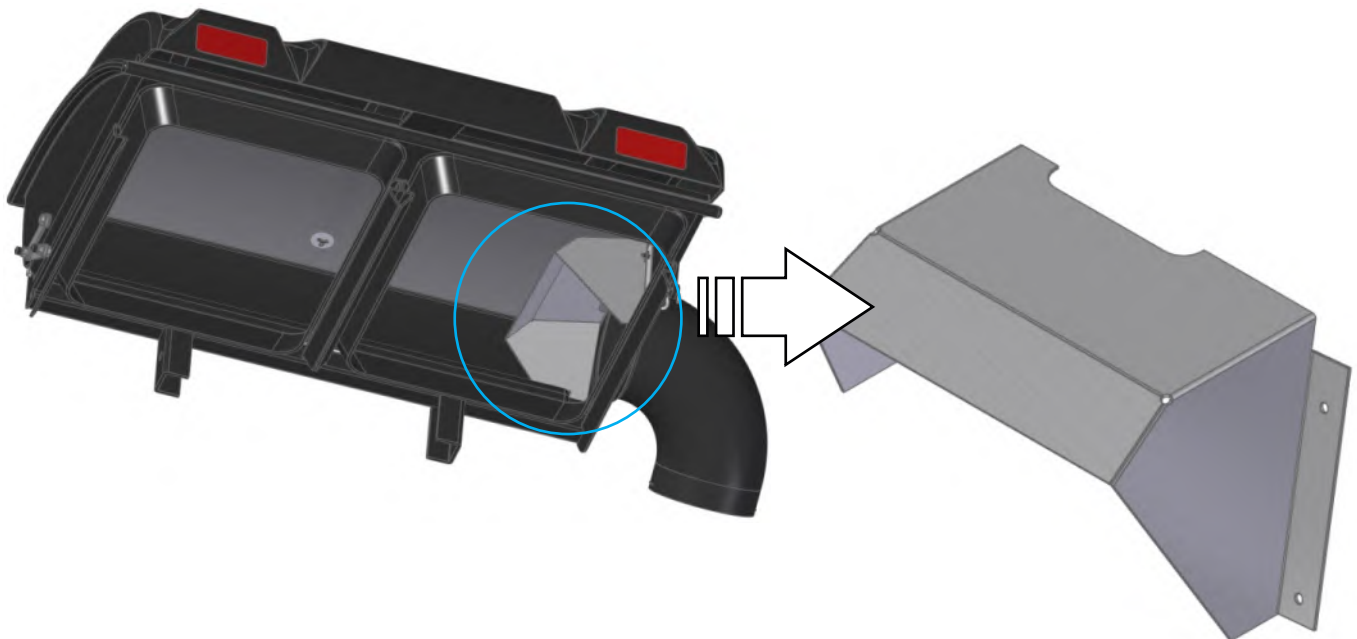

Bag Assembly

First, take one of the Bag Ring Split Ends and insert it through the Bag Seam Opening. Next, rotate the Bag around the Bag Ring (1) full turn (360 degrees) until the Bag Ring Split Ends and the Bag Seam Opening are positioned on the same side. Then, connect the Bag Ring Split Ends using (1) End Connector. Last, rotate the Bag Ring and the End Connector Assembly (1/2") turn (180 degrees) to position the Connector opposite of the Bag Seam Opening. Note Final End Connector Location below in Figure A. Repeat for each Bag.

Figure A

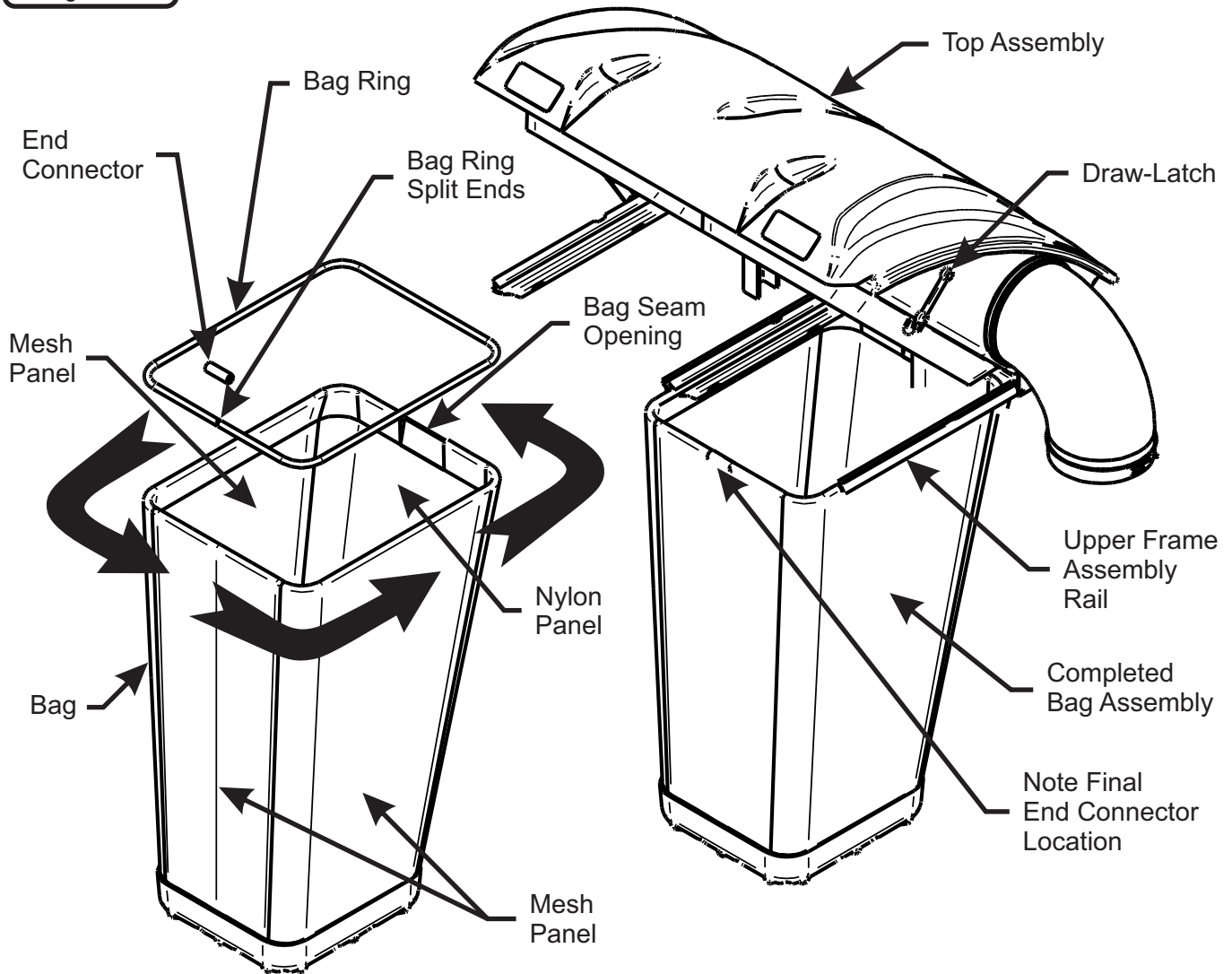

Bag Assembly Installation

Slide the Completed Bag Assembly into the Upper Frame Assembly Rails and close the Top Assembly. Fasten the Draw-Latch on either side to hold the bagger closed.

Boot Kit Assembly & Installation

Secure the Boot Plate (Item#2) to the Aluminum Boot (Item#1) using (2) 3/8"-16 x 1" Carriage Bolts (Item#3) and (2) 3/8"-16 Ny-Flange Lock Nuts (Item#4). Insert the Carriage Bolts from the inside of the Boot so the threads are on the top of the Boot. This will prevent grass clippings from collecting on the threads. Leave the hardware loose until the Boot Plate has been attached to the mower deck. Refer to Figure A.

Remove the hardware from the grass deflector and insert (1) Boot Rod (Item#5) into the grass deflector mounting holes as shown in Figure B. Secure the Boot Rod using (1) Hair Pin Clip (Item#6). With the Carriage Bolts still loose, adjust the position of the Boot so that there is no gap between the mower deck and the Boot. Tighten the hardware at this time.

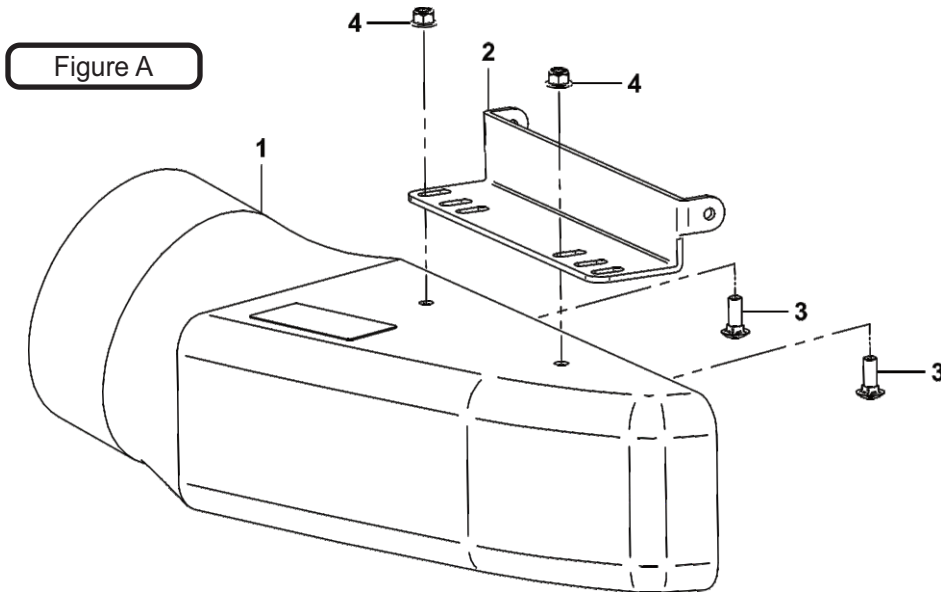

Item #	Part #	Desc.	Qty.
1	E0032A	Modified E0032	1
2	B0820	Boot Plate	1
3	K1182	Carriage Bolt 3/8"-16 x 1"	2
4	K2038	Ny-Flange Lock Nut 3/8"-16	2
5	B4331	Boot Rod	1
6	K0099	Hair Pin Clip 3/32"	1

Figure B

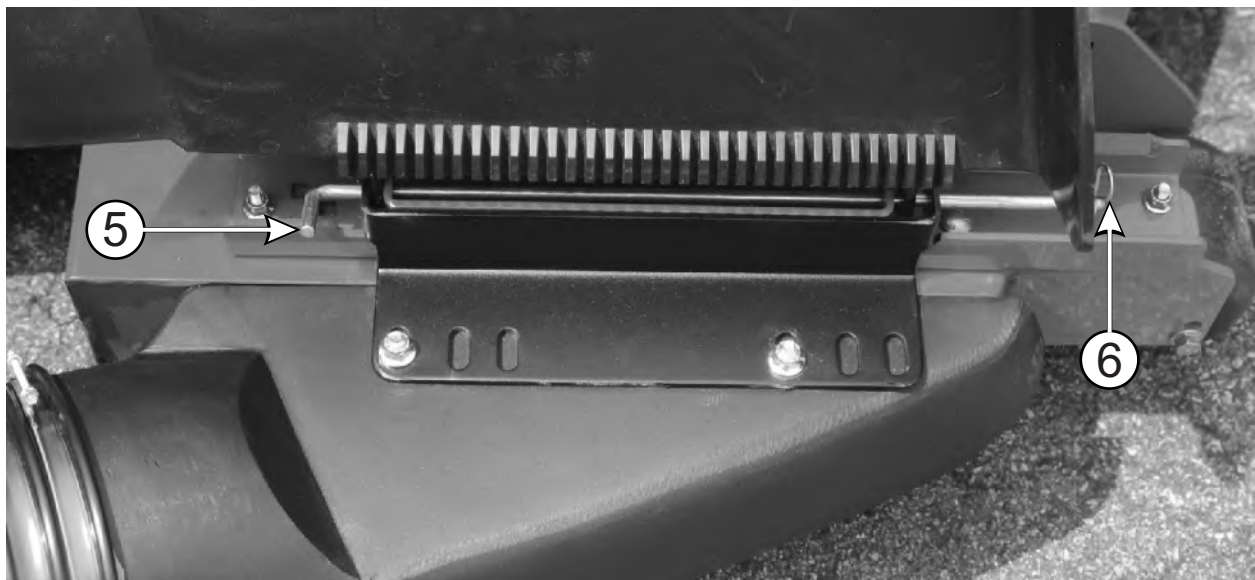

Blower Cone Installation

Thread (1) 5/16"-18 Jam Nut P#(K0120) onto each end of (2) 5/16"-18 x 2-1/2" HHCS P#(K0125) as shown in Figure B.

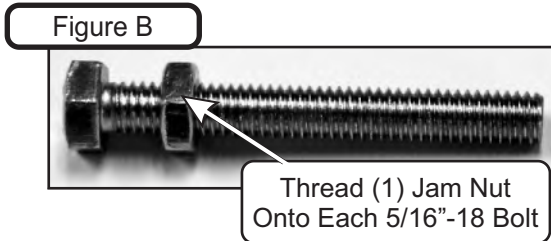

Now partially thread (1) bolt into each of the two threaded bosses located on the Blower Housing. Place 8" Blower Cone P#(E6009) so the two tabs line up with the bolts and tighten completely as shown in Figure C.

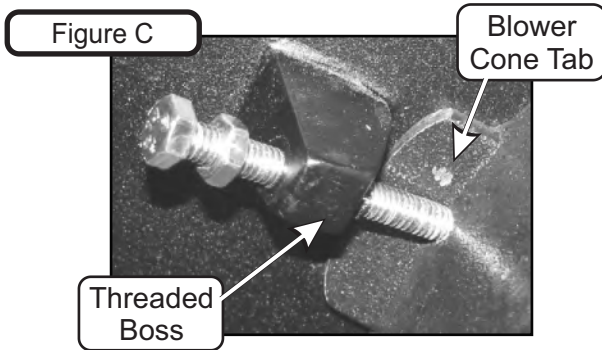

Once the (2) bolts are tight, tighten the Jam Nuts against the threaded boss as shown in Figure D.

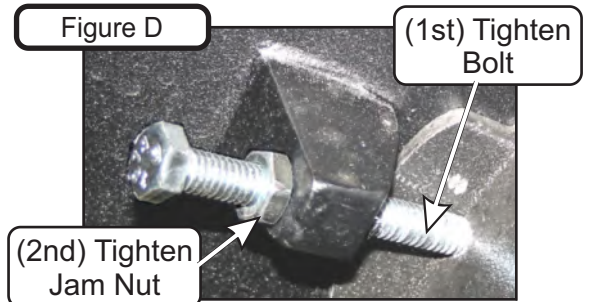

Refer to Figure E for proper Blower Cone installation reference.

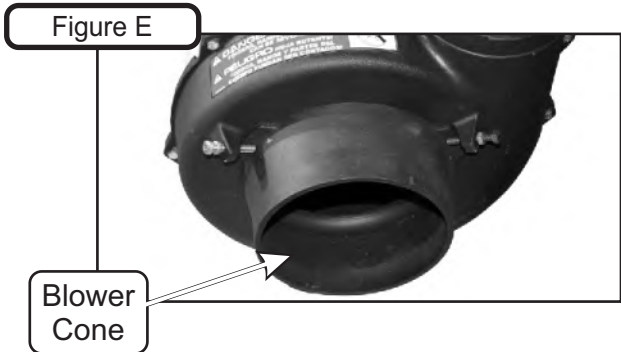

Length Of Hose Adjustment

The hoses in the following steps must be cut to fit your machine. Do not cut the hoses until you have tried to fit them on your machine. Remember that the hoses need to be long enough to allow for the opening and closing of the collection system as well as allowing ample clamping surface between each component.

Upper Hose Installation

Slide a Hose Clamp P#(J0060) over one end of the 6" Upper Hose. Secure this end of the 6" Upper Hose to the Blower Outlet. See Figure below for details. Secure opposite end of the 6" Upper Hose to the Inlet. Make sure both ends are securely fastened by tightening the Hose Clamp and rotating the Inlet Snap Fastener towards the hose to lock in place.

Lower Hose To Blower Cone Installation

Slide a 8" Hose Clamp P#(J0080) over both ends of the 8" Lower Hose. Secure one end of the Lower Hose to the Blower Cone and fasten by tightening the Hose Clamp.

Lower Hose To Boot Installation

Take the unattached end of the Lower Hose and secure it to the circular end of the Boot and fasten by tightening the Hose Clamp.

Tip: Before securing Hose Clamp fully, rotate Lower Hose counter-clockwise (away from yourself) approximately 1" to aid in retaining Boot to mower deck.

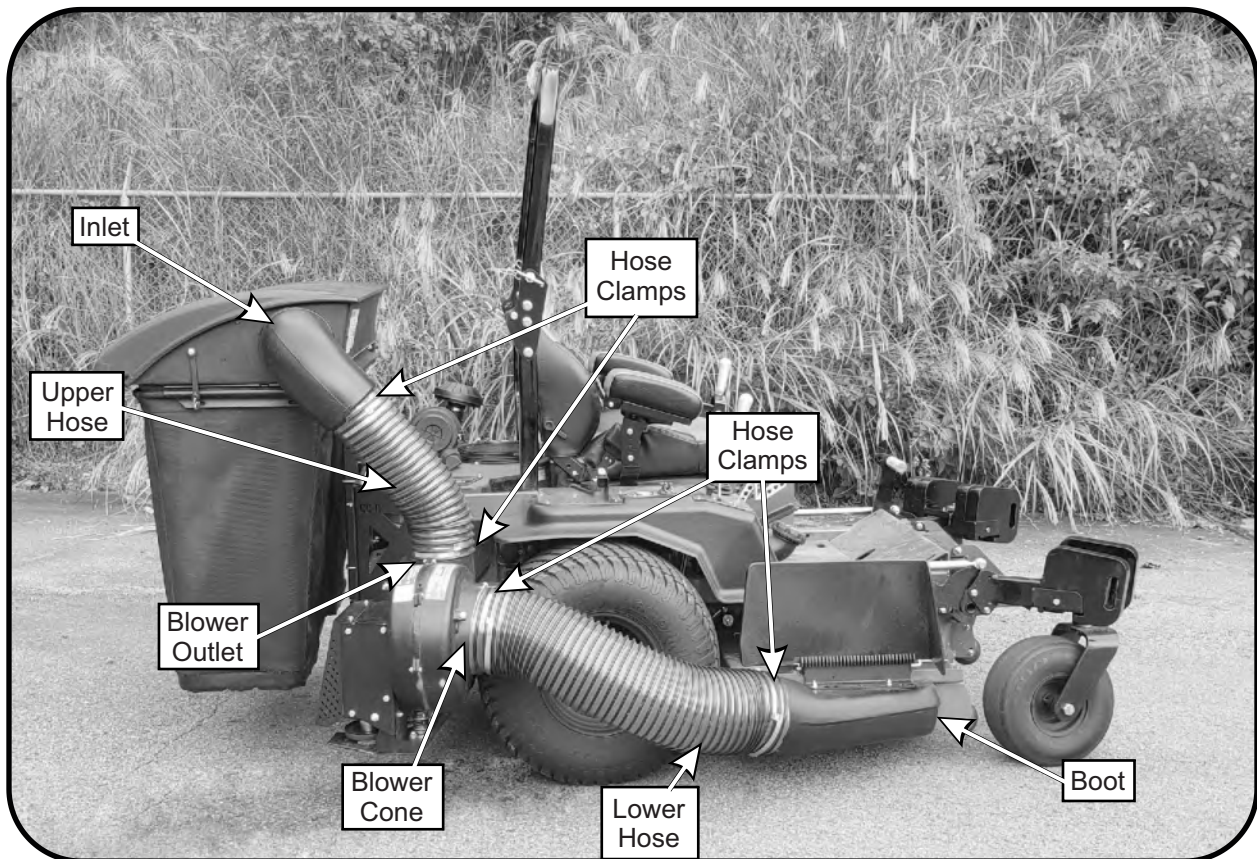

Wire Harness Installation



WARNING

**To Prevent Serious Injury-
Proper Installation Of Safety Interlock Harness
Is Mandatory. Please Check That All Interlock
Points Work Correctly Once Installed.**

Before installing the PTO Switch Plate, install the PTO Rocker Switch by positioning it over the Switch Plate and firmly pressing the Rocker Switch down until it is seated in place. Make sure the 'FAN' Symbol is positioned to the 'ON' side of the PTO Switch Plate. Refer to Figure A.

Once installed, connect the Wire Harness' (2) Female Switch Disconnects to the PTO Rocker Switch. Refer to Figure B for the Wire Harness components and Figure C on the next page for installation diagram.

To install the PTO Switch Plate , (#1) remove the corner hardware to the right of the operator's seat as shown in Figure A on the panel cover and set it aside. Next, Place the PTO Switch Plate over the mount hole on the panel cover aligning the slot with the corner mount hole. Secure the Switch Plate by using the previously removed hardware. Refer to Figure A below.

Next, route the (#2) Negative Lead (-) and the Positive Lead (+) of the Wire Harness to the negative & positive terminal of the mower's battery. Refer to Figure B for the Wire Harness components, refer to Figure C on the next page for the Wire Harness to mower connection.

Figure A

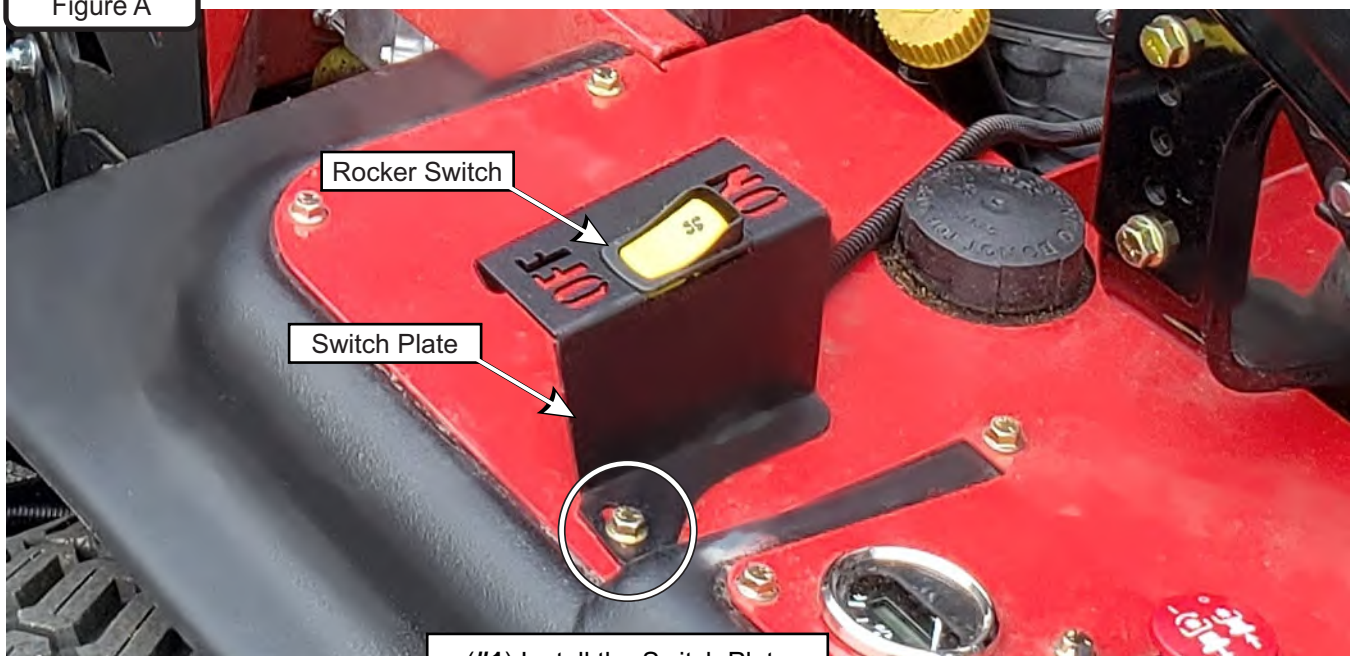

**(#1) Install the Switch Plate
on the Operator's right side
using pre-existing hardware**

Figure B

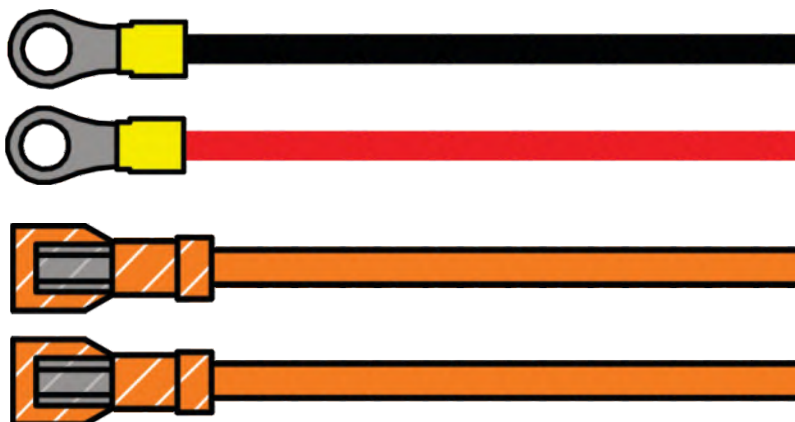

Negative Lead (-) to
Negative Terminal (-)

Positive Lead (+) to
Positive Terminal (+)

(2) Female Switch Disconnects
to PTO Rocker Switch

Wire Harness Installation (Continued)

Route the Wire Harness back towards the engine located behind the operator's seat. Disconnect the mower's clutch connector and (#3) interconnect it with the Wire Harness' Clutch Connection Jumper. Refer to Figure C & Figure D. Refer to the Wiring Diagram on Page 28 for the Connection Jumper Types.

Lastly, route the (#4) Wire Harness back towards the rear of the mower positioning the Wire Harness under the Bottom Bracket / Mount Arm. Then connect the Wire Harness to the PTO Unit. Refer to Figure C and Figure E on the next page.

Figure C

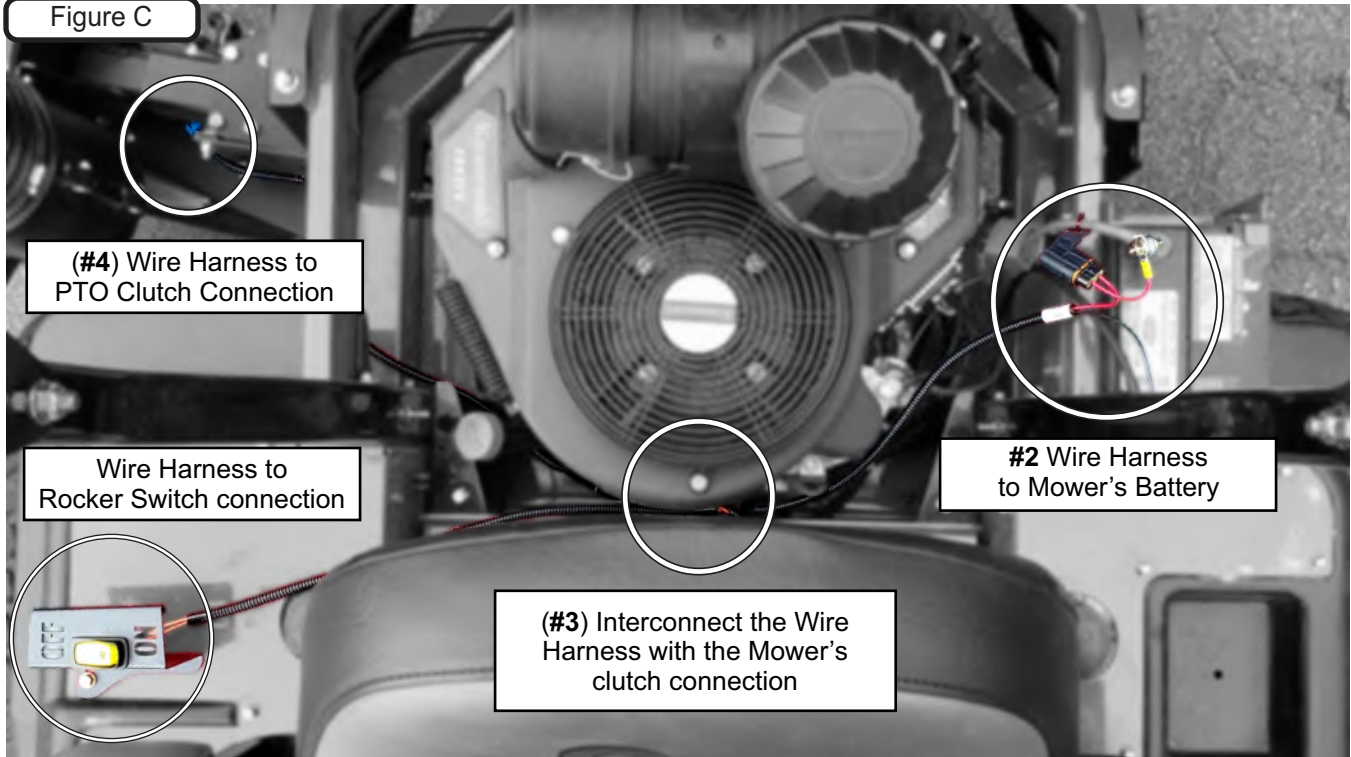
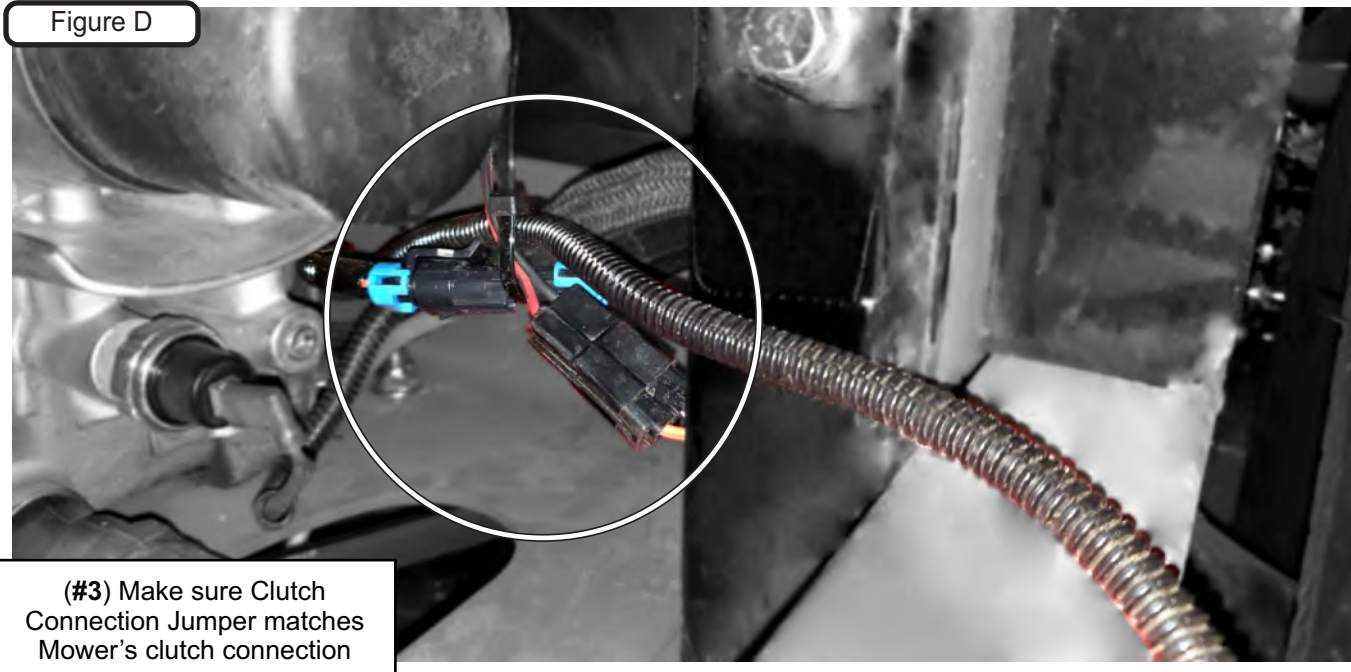

Figure D



Wire Harness Installation (Continued)

Figure E



Note: It is recommended to secure the Wire Harness to the mower by using the included Cable Ties once you have the Wire Harness installed. Be sure the Wire Harness is routed so that it does not obstruct any part of the mower that may damage the Harness.

When routing the Wire Harness back towards the PTO unit, it is recommended to use the Cable Tie point to secure the Wire Harness to the Right Frame Bracket to prevent the Wire Harness from moving. See Figure F below.

Figure F

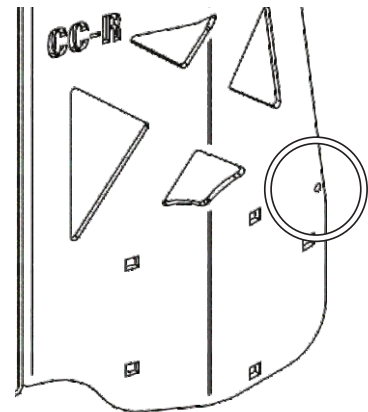

Wire Harness Installation (Continued)

Note: Select the Jumper that fits your mower's clutch connection and connect it to the Wire Harness' Connector Jumper

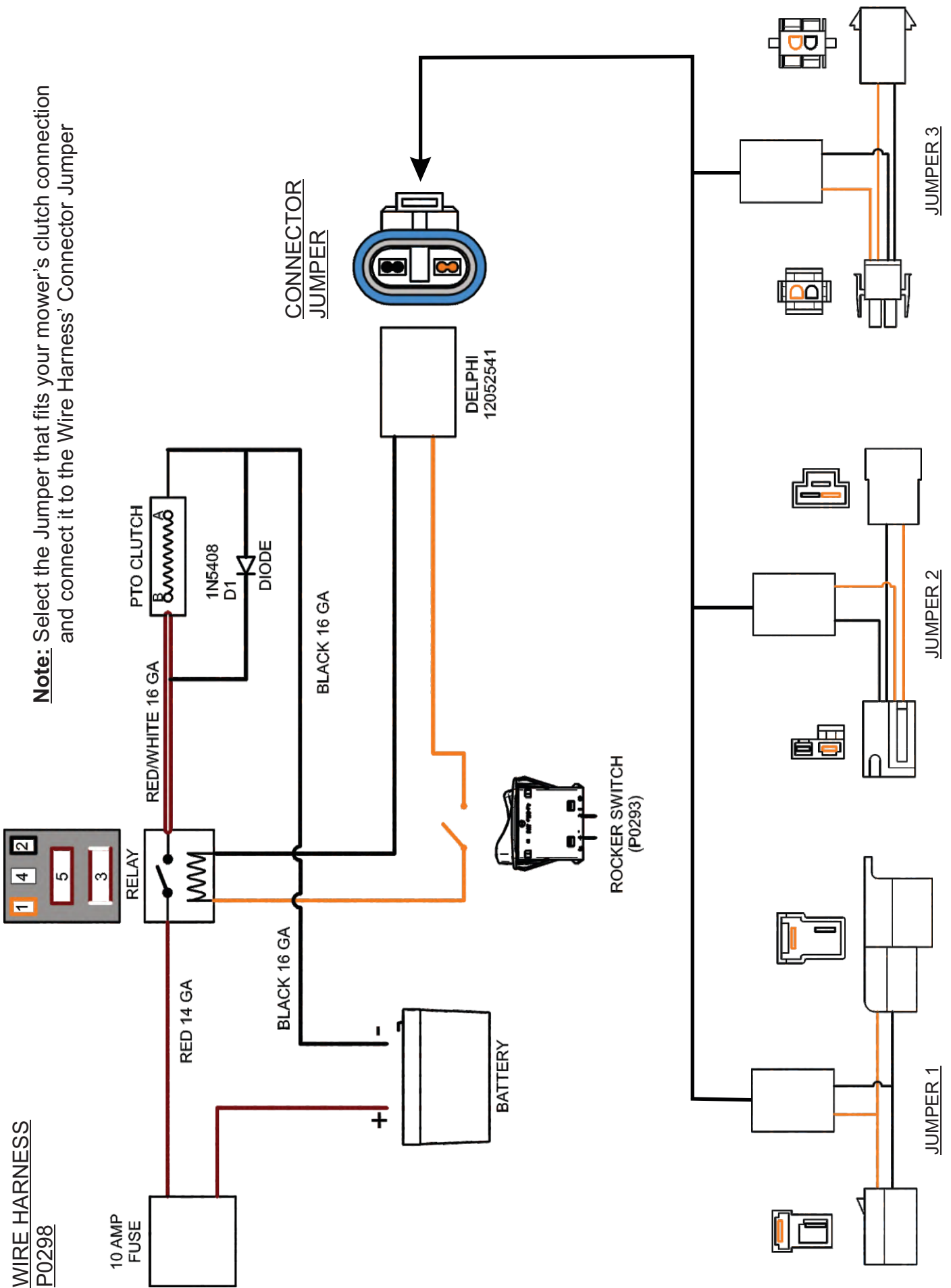

Weight Kit Installation

Position the Quad Weight Bracket Base (Item #2) under the caster tubing w/ opening towards caster fork. Next, position the Weight Bracket Clamp (Item #3) on top of caster tubing w/ opening towards caster fork.

Align the (4) holes of the Weight Bracket Clamp (Item #3) to the holes in the Quad Weight Bracket Base (Item #2). Loosely fasten the Weight Bracket Clamp (Item #3) to the Weight Bracket Base (Item #2) using (4) 5/16"-18 x 3" Bolts (Item #4.1) & (4) 5/16"-18 Ny-Flange Lock Nuts (Item #4.2).

Position the Weight Bracket Base and the Weight Bracket Clamp assembly along the caster tubing to prevent interference from caster forks or any other objects. Tighten the fasteners in an 'X' pattern until assembly is firmly clamped to caster tubing. Do not over tighten which may result in bending Weight Bracket Clamps (Item #3).

To Install the Weights, insert (2) Weights (Item #1) Into the Weight Bracket Base (Item #2) & align the holes of the Weights w/ the holes of the Weight Bracket Base (Item #2). Fasten the Weights (Item #1) to the Weight Bracket Base Using (1) Clevis Pin (Item #4.3) & (1) Hair Pin Clip (Item #4.4). Repeat for additional Weights.

Refer to the Figure Below.

MY2021 : Install all (4) Weights (Item #1) on the Left Caster & ONLY (2) Weights (Item #1) on the Right Caster.

MY2022 : Install all (4) Weights (Item #1) on BOTH the Left & Right Caster.

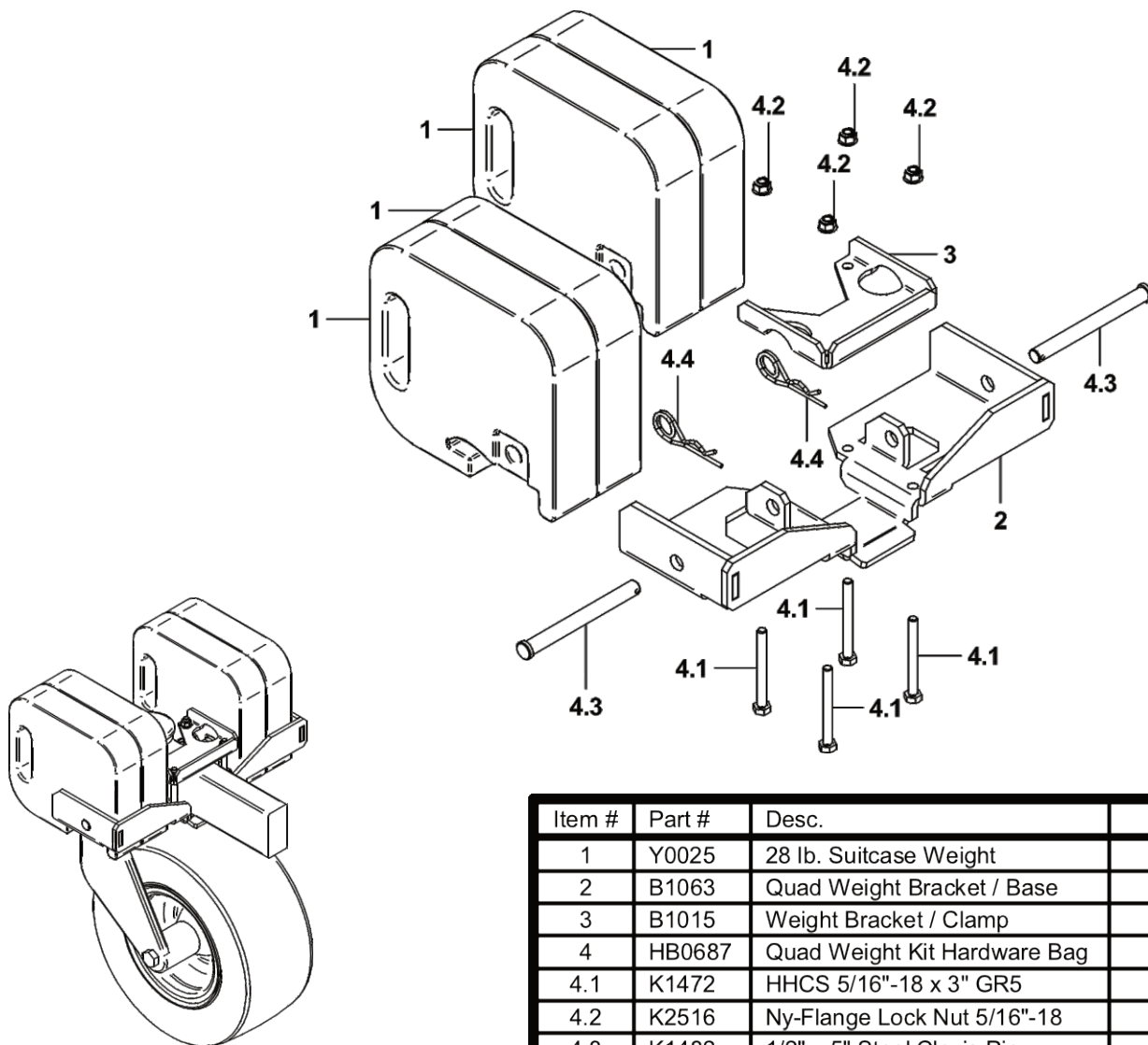

Item #	Part #	Desc.	Qty.
1	Y0025	28 lb. Suitcase Weight	4
2	B1063	Quad Weight Bracket / Base	1
3	B1015	Weight Bracket / Clamp	1
4	HB0687	Quad Weight Kit Hardware Bag	1
4.1	K1472	HHCS 5/16"-18 x 3" GR5	4
4.2	K2516	Ny-Flange Lock Nut 5/16"-18	4
4.3	K1482	1/2" x 5" Steel Clevis Pin	2
4.4	K1478	Hair Pin Cotter / Double Loop	2

Impeller Blade Removal/Replacement

To Remove: First remove the 5/16"-24 x 1" HHCS (#1), Taper Lock Bushing Washer (#3), (2) 5/16 Flat Washers and Spacer Bushing (#4) from the Taper-Lock Bushing (#5). Next remove the (2) 1/4"-20 x 1" HHCS (#2) and place them into the threaded holes of the Taper-Lock Bushing (#5). Gradually thread each bolt evenly into the Taper-Lock Bushing, forcing the blade to break-away from the Taper-Lock Bushing. If the Impeller will not move, carefully hit the base of the Impeller, between each vein, with a hammer, then try again.

To Replace: Place Impeller Blade over the engine shaft. Slide the Taper-Lock Bushing (#5) on to the engine shaft and into the Impeller Blade, aligning the **non-threaded** holes of the Taper-Lock Bushing to the threaded holes of the Impeller Blade. Fasten by using (2) 1/4"-20 x 1" HHCS (#2), (1) Spacer Bushing (#4) (1) Taper-Lock Bushing Washer (#3), and (1) 5/16"-24 x 1" HHCS (#1). Torque to the proper specifications in the torque chart on the back of this manual. Next, rotate the Impeller Blade to ensure that the blade is clear of contact on all sides of the blower housing.

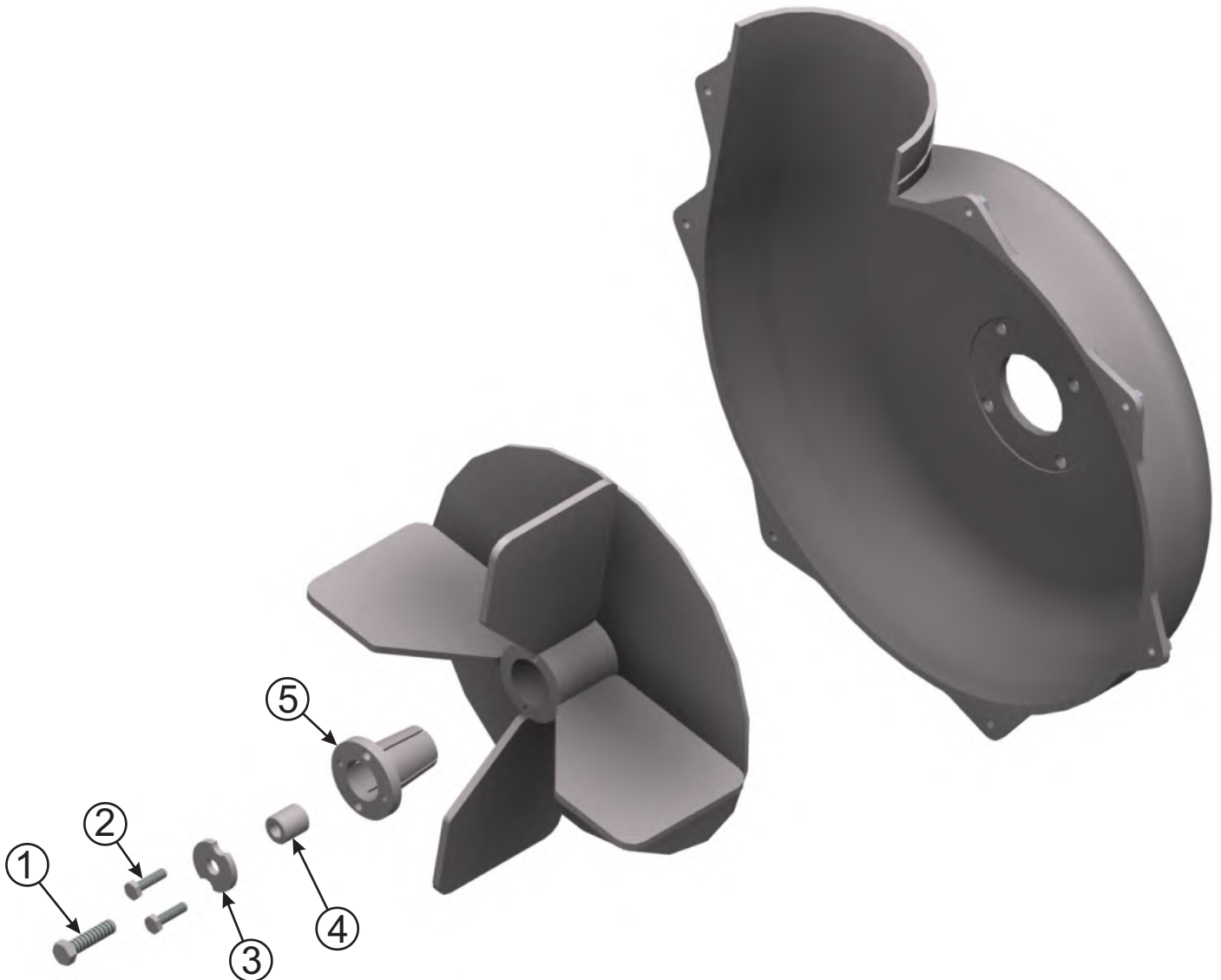

A2207 Mount Arm / Receiver Tube Assy

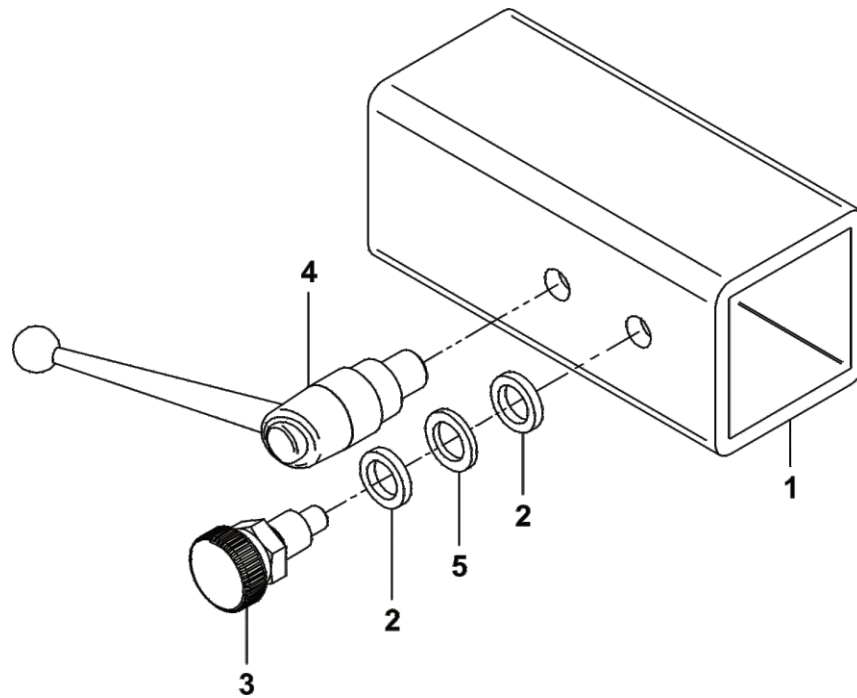

Item #	Part #	Desc.	Qty.
1	B0931	Tube / Mount Arm	1
2	J0013	Nylon Flat Washer 1/2" x .750" OD Grade 6/6	2
3	J0020	Knob Plunger Pin 1/2"-13	1
4	J0009	Adjustable Handle 1/2"-13 x .59 Male	1
5	K0027	Flat Washer 1/2" / .787 OD x .512 ID x .090 T	1

A2092 Idler Arm Assembly

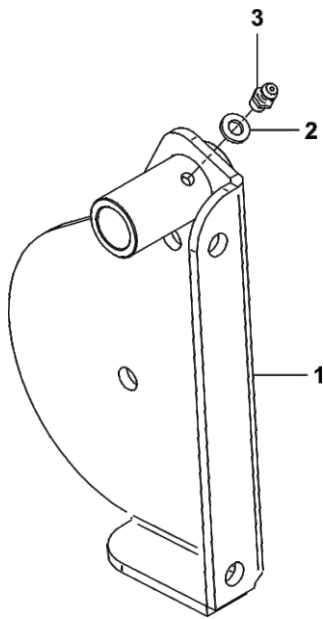

Item #	Part #	Desc.	Qty.
1	A2070_01	Idler Arm Weldment	1
2	K1467	Flat Washer M6 x 12mm OD	1
3	J0801	1/4\"-28 Zirc Fitting	1

A2067_02 Idler Mount Assembly

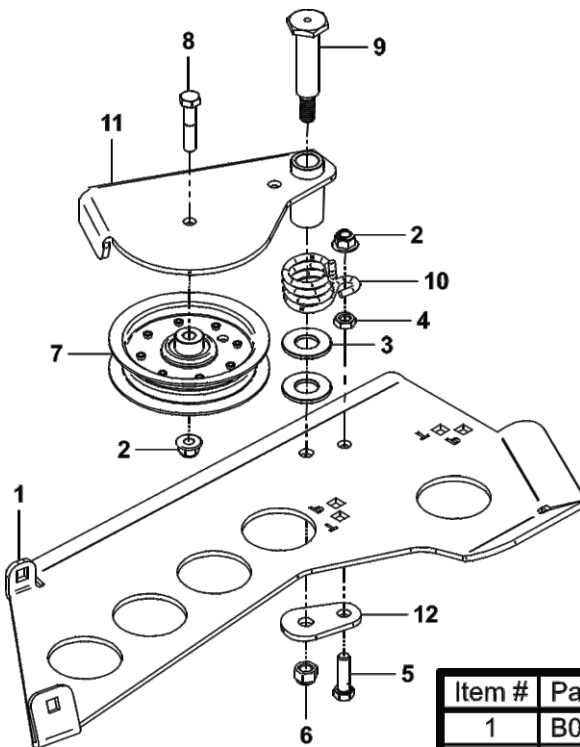

Item #	Part #	Desc.	Qty.
1	B0958_02	Idler Mnt PI	1
2	K2038	Ny-Flange Lock Nut 3/8\"-16	2
3	K1463	Flat Washer .720 ID x 1.500 OD x .250 T	2
4	K1219	Jam Nut 3/8\"-16	1
5	K1192	HHCS 3/8\"-16 x 1-1/4\" GR5	1
6	K0329	Nylock Nut 7/16\"-14 GR8	1
7	M0003	Idler Pulley	1
8	K1462	HHCS 3/8\"-16 x 1-3/4\" GR8	1
9	K1464	Shoulder Bolt 7/16\"-14 / Idler	1
10	J0024	Torsion Spring	1
11	A2092	Idler Arm Assy.	1
12	B0974	Idler Base Plate	1

A2058 01 Gearbox Sub-Assembly Exploded Parts View

Item #	Part #	Desc.	Qty.
1	A2048	Clutch Flange	1
2	M0002	Gearbox	1
3	N0005	7/8" Pillow Block Bearing / Fenner	1
4	J0272	Woodruff Key #9	1
5	K0035	Set Screw 5/16"-18 x 1/4" Cup Point	1
6	K0428	HHCS 5/16"-24 x 1" GR9	1
7	K0043	Lock Washer 5/16"	1

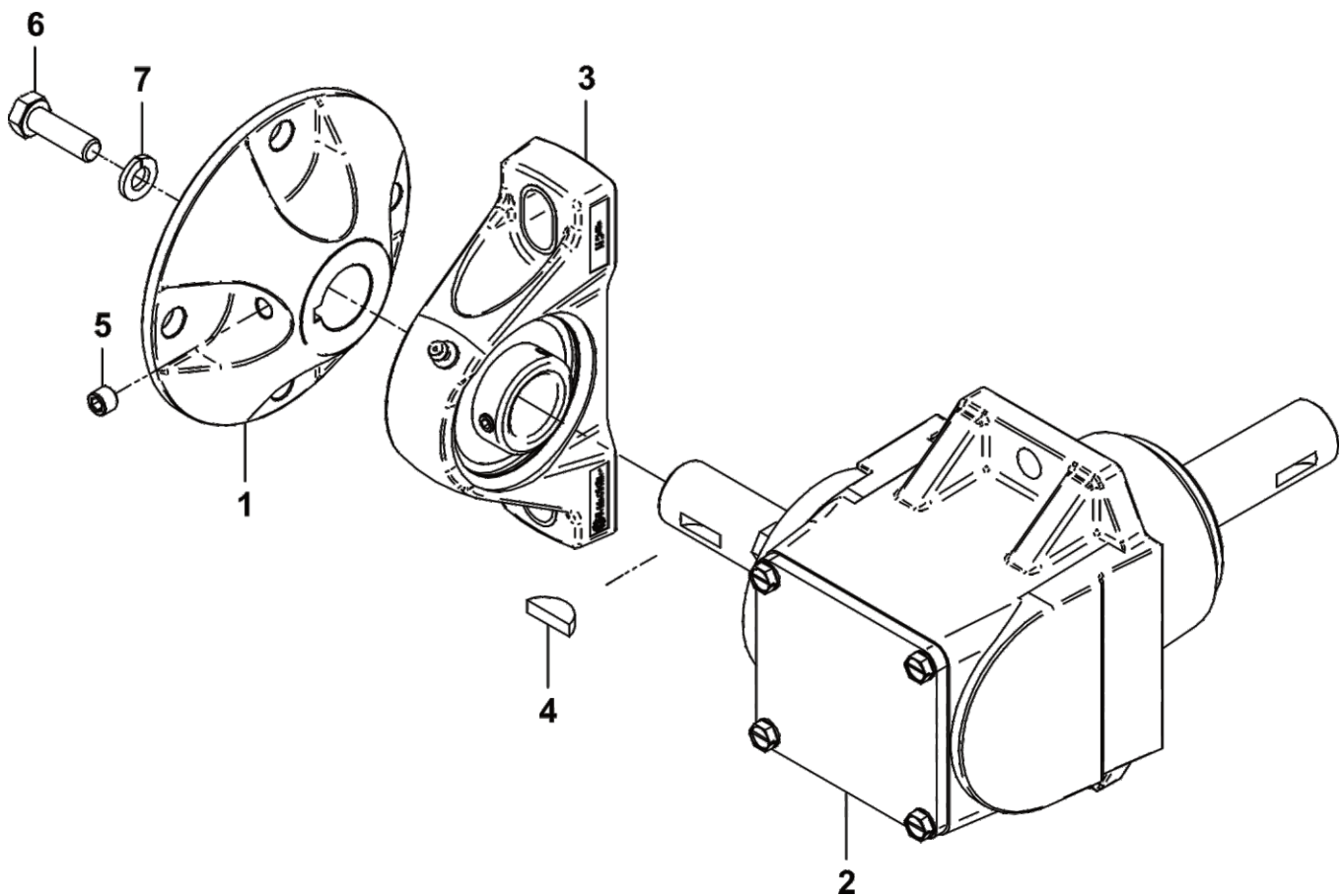

A2059 02 Clutch Sub-Assembly Exploded Parts View

Item #	Part #	Desc.	Qty.
1	M0001_01	Electric Clutch	1
2	S0007	Clutch Shaft (Rev 1)	1
3	N0004	Flange Bearing / 1" ID / 2-Bolt	1
4	B2217	Clutch Lower Bearing Mnt.	1
5	S0239	Eng. Pulley Bushing #41	1
6	K0076	Key 1/4" x 3/4" Long	1
7	M0309	A-Section Pulley / 4.75 OD (PTO-X)	1
8	K1510	HHCS 3/8"-16 x 1-1/8" GR5 Zinc	2
9	K1121	3/8"-16 Nyloc Nut GR5	2
10	K0359	HHCS / 7/16"-20 x 4" w/ Patch	1
11	K0140	Lock Washer 7/16" / High-Collar Helical Spring	1
12	K0278	Double Indented Washer 7/16" / 1.375 OD x .440 ID x .179 T	1

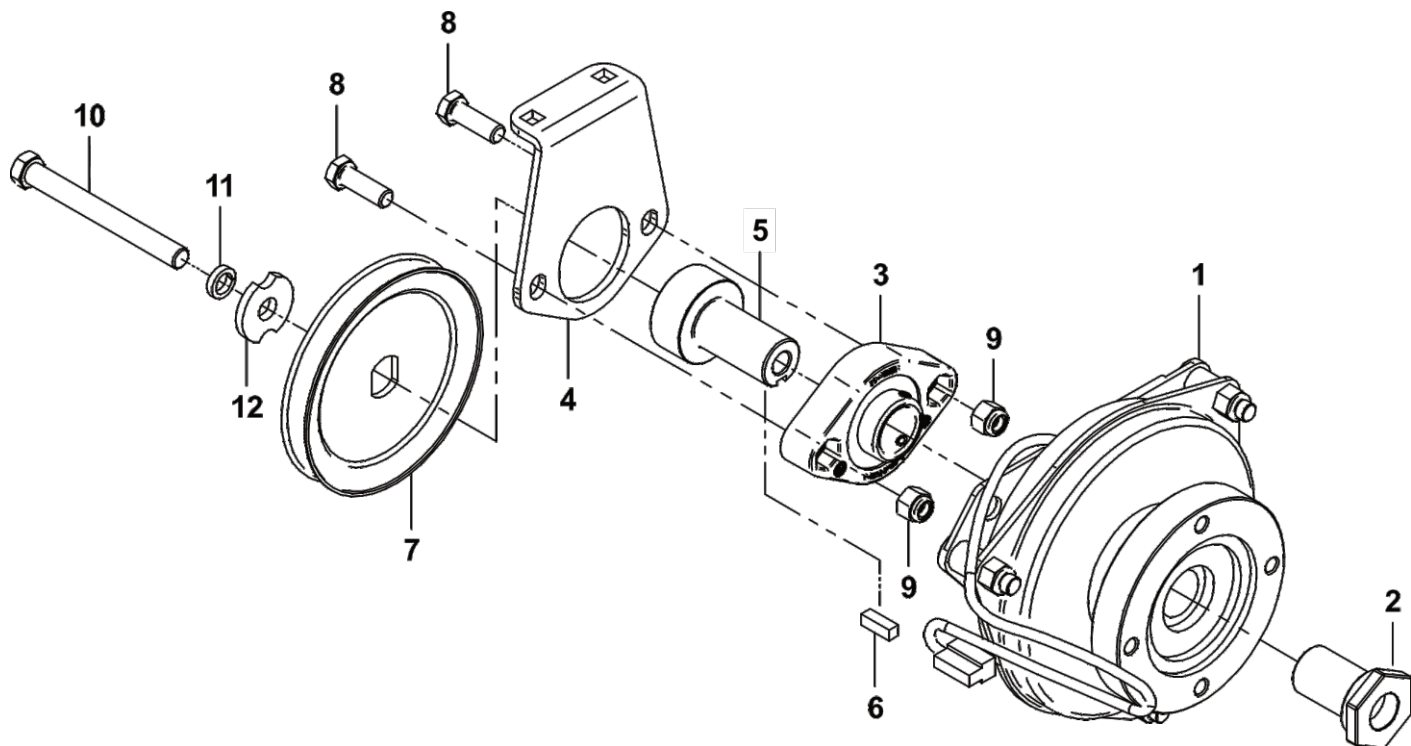

A2057 02 Drive Assembly Exploded Parts View

Item #	Part #	Desc.	Qty.
1	A2058_01	Gearbox Sub-Assy	1
2	A2059_02	Clutch Sub-Assy	1
3	K0343	HHCS 3/8"-16 x 7/8" GR8	4
4	K0048	Lock Washer 3/8"	4

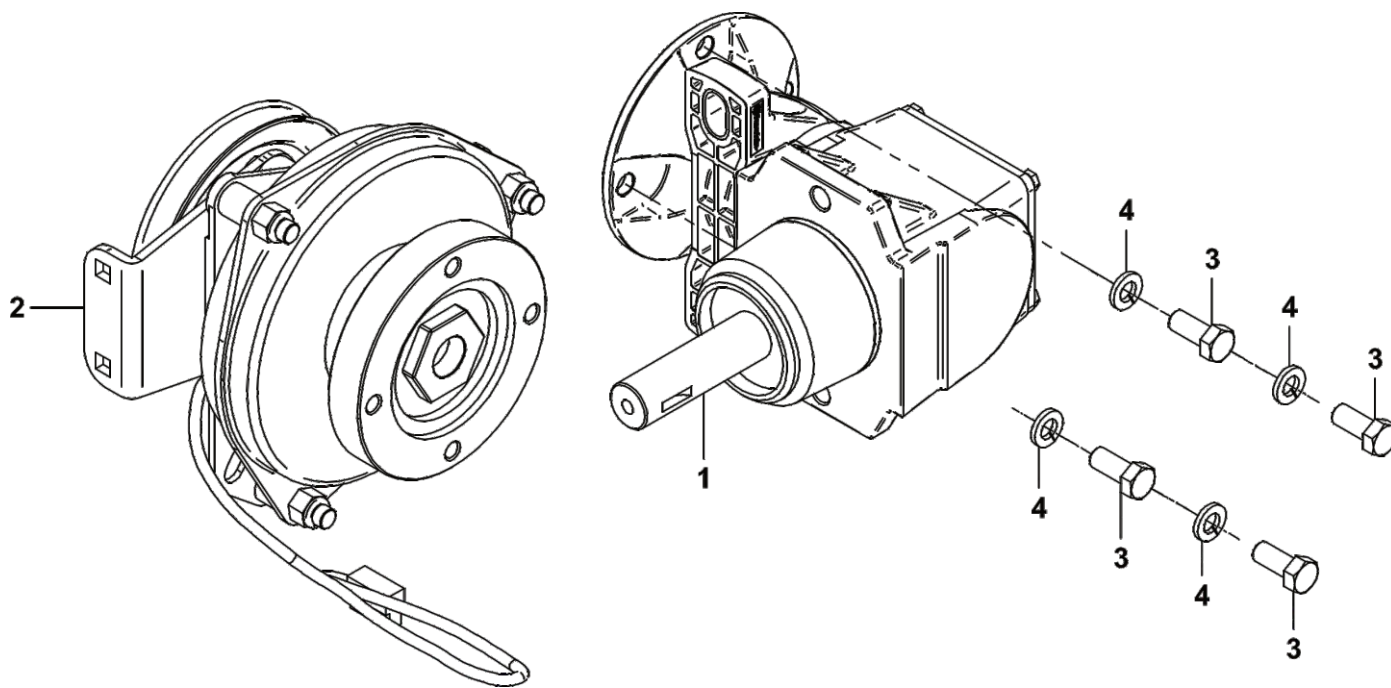

A2060 02 Mounted Drive Assembly
Exploded Parts View

Item #	Part #	Desc.	Qty.
1	A2034	Drive Mnt Assy	1
2	A2057_02	Drive Assy	1
3	B0940	Spacer Plate	1
4	K1511	SHCS 1/2"-13 x 2" A574 Zinc	2
5	K0057	Lock Washer I/T 1/2" / Zinc	2
6	K1512	SHCS 3/8"-16 x 1" A574 Zinc	2
7	K0048	Lock Washer 3/8"	2

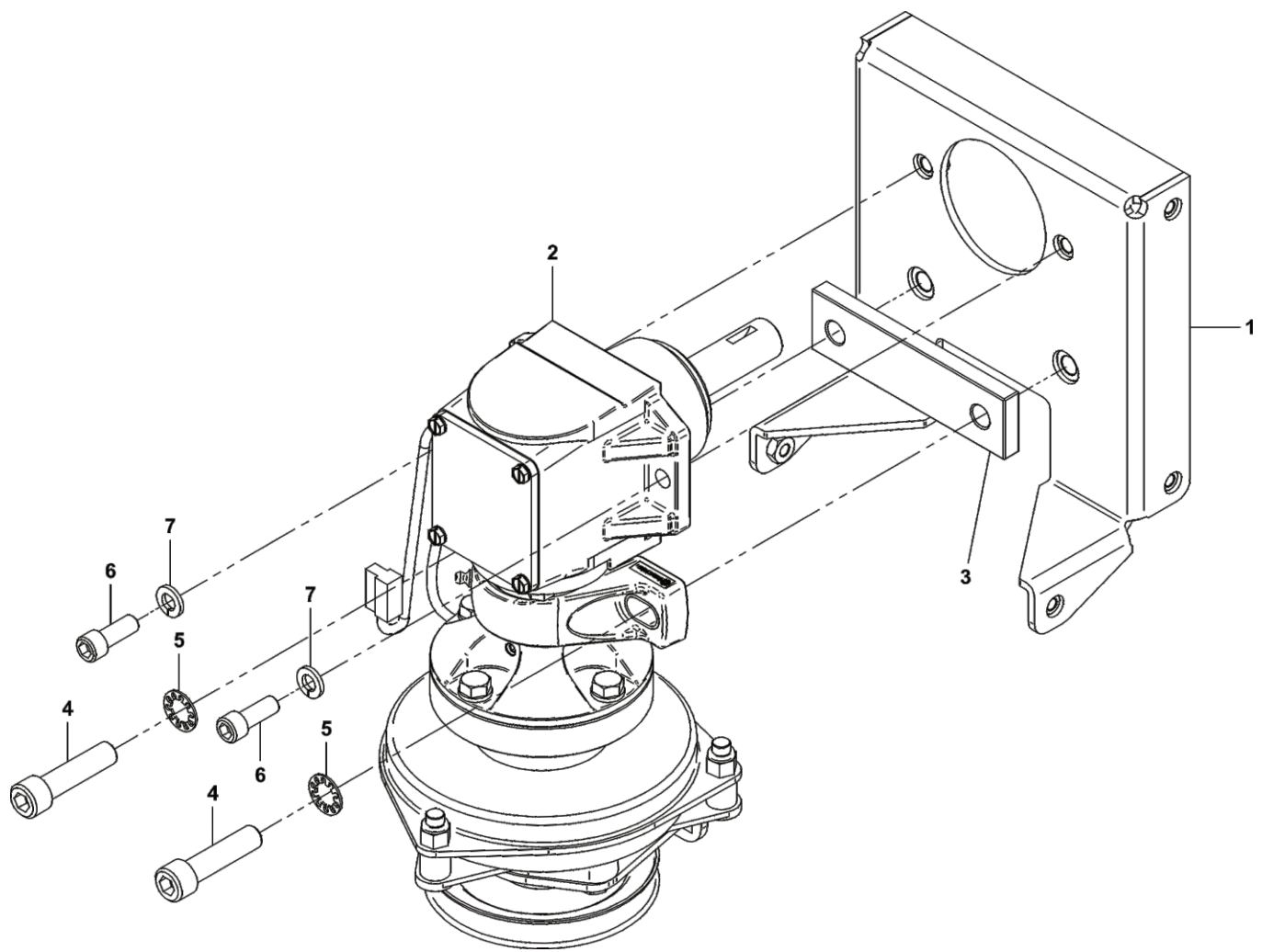

A2039 03 Base Drive Assembly

Exploded Parts View

Item #	Part #	Desc.	Qty.
1	A2060_02	Mounted Drive Assy	1
2	A2035_02	Housing Mnt Assy	1
3	B1100_01	Idler Assy Mount Plate	1
4	B0942_02	Anti-Rotation Brkt	1
5	A2032	Drive Arm Assy	1
6	B0938_01	Drive Guard	1
7	K1153	HHCS 5/16"-18 x 3/4"	4
8	K1154	HHCS 5/16"-18 x 1"	4
9	K0043	Lock Washer 5/16"	8
10	K1142	5/16"-18 x 3/4" Carriage Bolt	6
11	K2516	Ny-Flange Lock Nut 5/16"-18	6
12	K0343	HHCS 3/8"-16 x 7/8" GR8	1
13	K1477	Flat Washer / 3/8" / .406 ID x .812 OD x .125 Thk	1
14	K1476	Reverse Lock Nut / 3/8"-16 Grade C	1
15	P0271	Quick Connect Wire Harness	1
16	K0353	HWHTCS 1/4"-20 x 1/2"	2

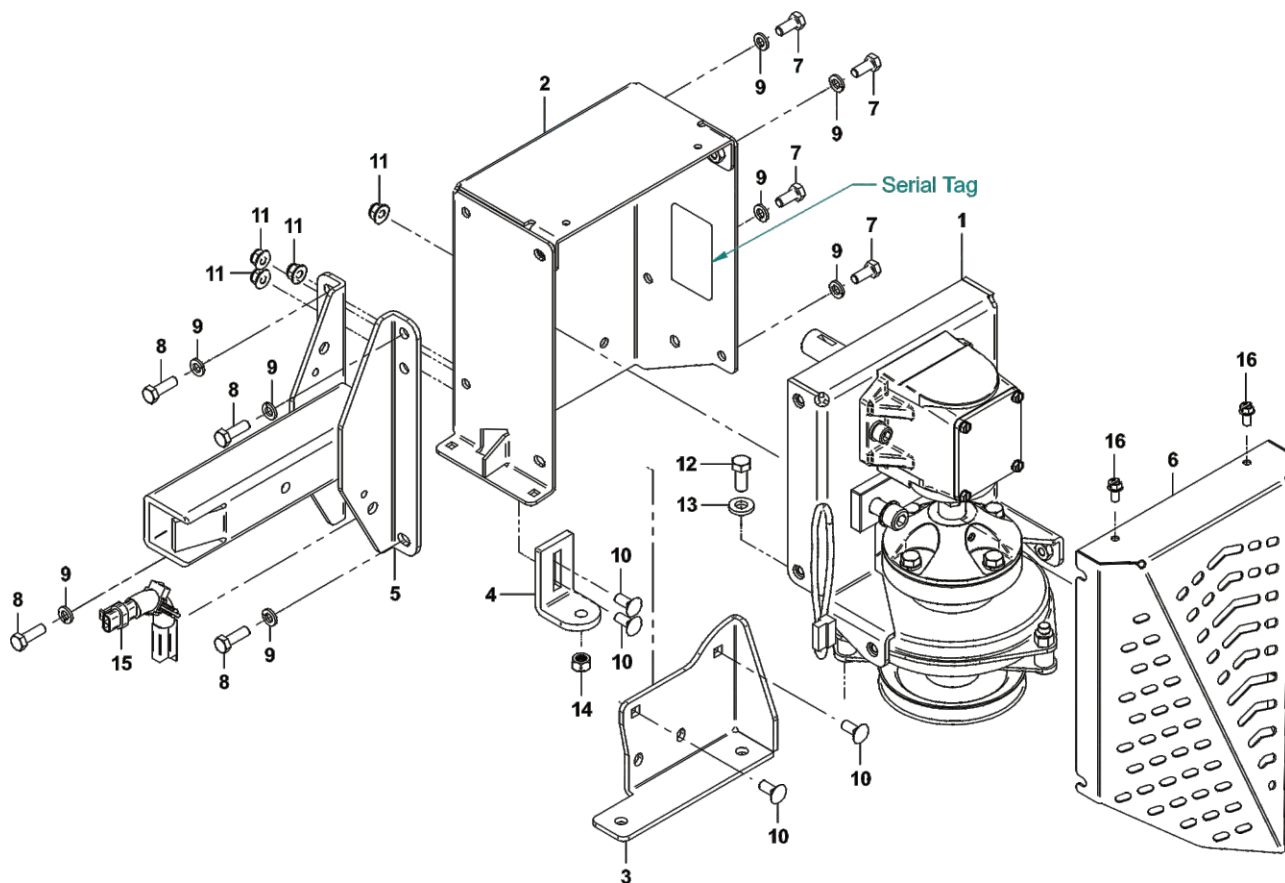

A2061 03 Drive Assembly / 4 Blade Impeller

Exploded Parts View

Item #	Part #	Desc.	Qty.
1	A2039 03	Drive Assy / Base 1.5	1
2	A0645	4-Blade Impeller Weldment	1
3	E4052B	Blower Hsg Back	1
4	E4052F	Blower Hsg Front	1
5	K1154	HHCS 5/16"-18 x 1"	4
6	K0044	I/T Tooth Lock Washer 5/16"	4
7	S0157	Taperlock Bushing 7/8"	1
8	K1225	HHCS 1/4"-20 X 1" GR8	2
9	S0159	Spacer Bushing .938 OD x .325 ID x .345 T	1
10	K0042	Flat Washer 5/16" / .875 OD x .380 ID x .075 T	2
11	K0284	Double Indented Washer 3/8" / 1.375 OD x .380 ID x .179 T	1
12	K1465	HHCS 5/16"-24 x 1-1/2" GR8	1
13	K1401	1/4"-20 x 1" SHCS / Zinc / GR8	7
14	K1126	Flange Nut 1/4"-20	7

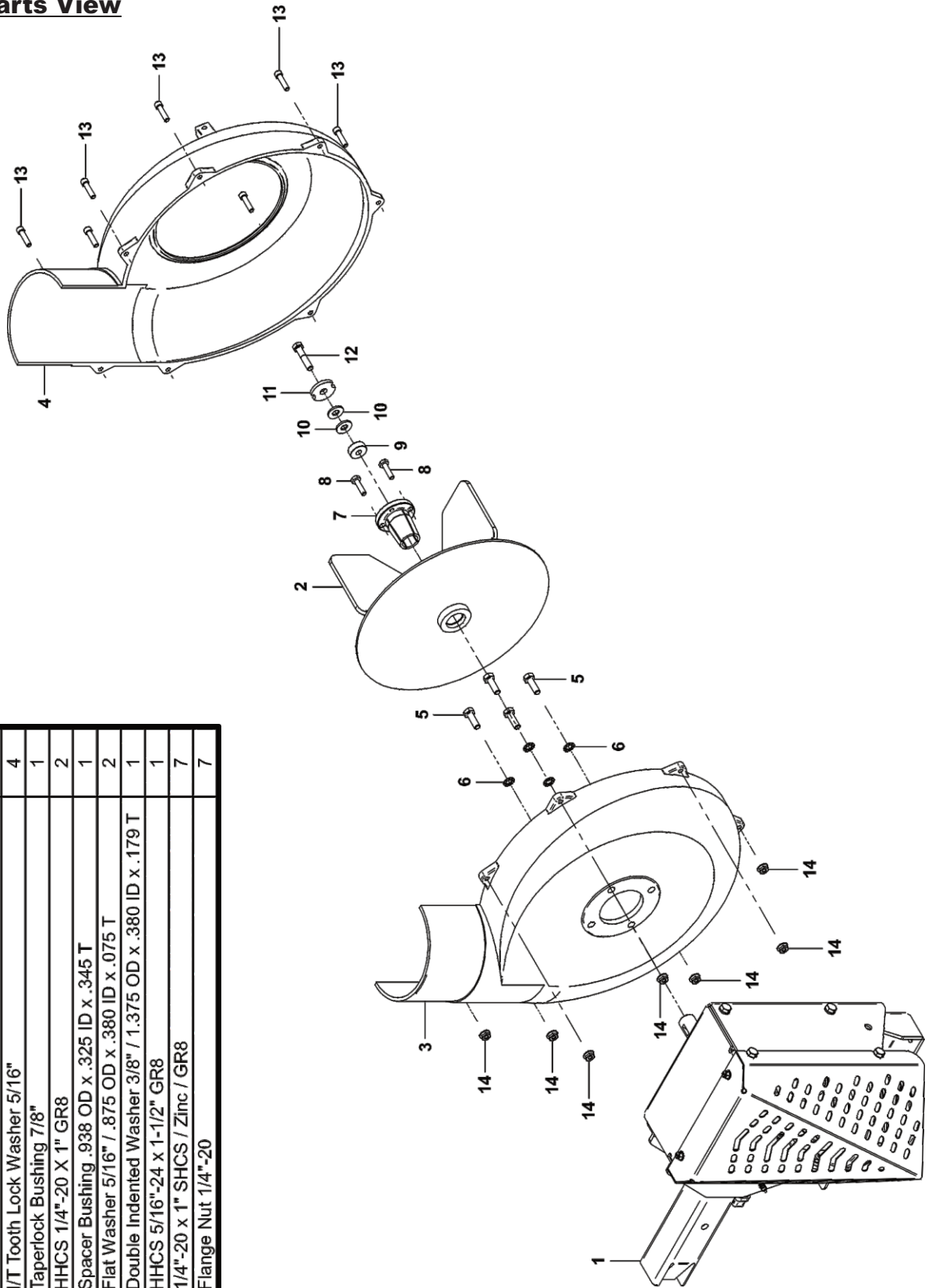

A1158 Top Assembly Exploded Parts View

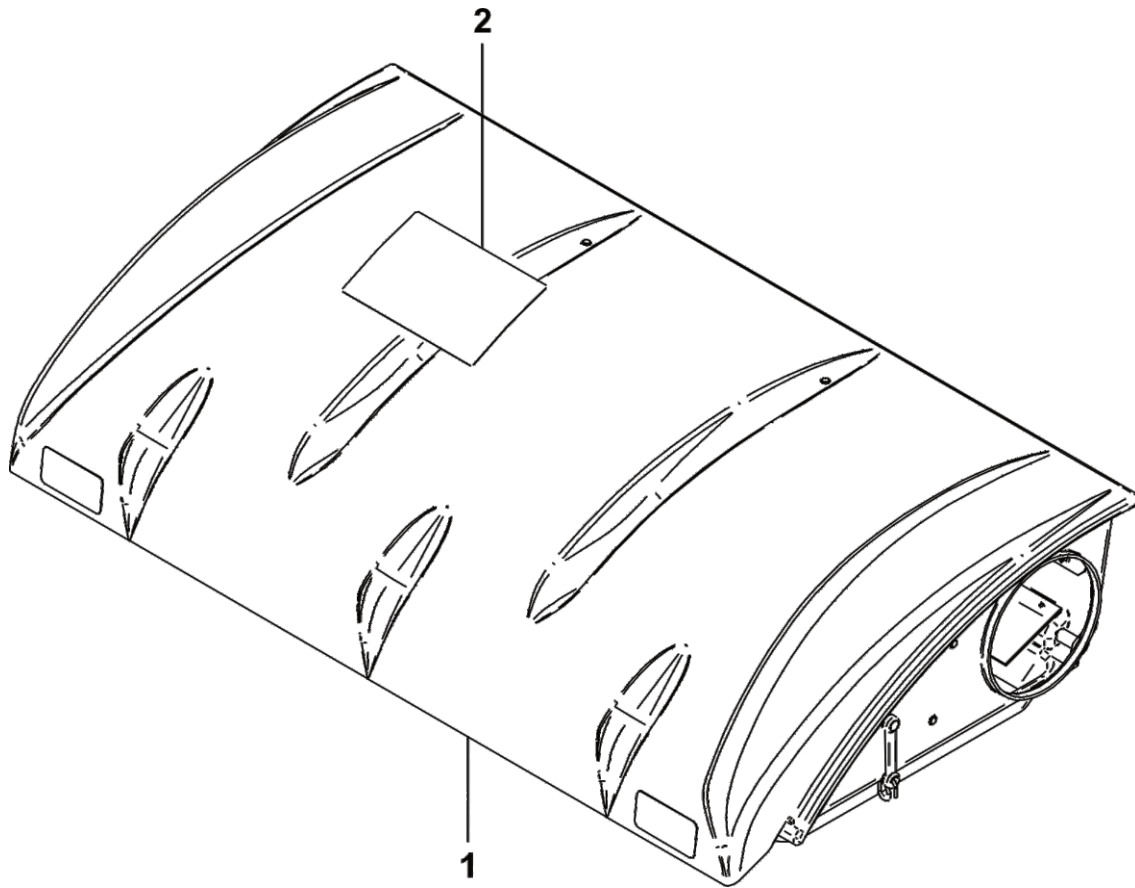

Item #	Part #	Desc.	Qty.
1	A1157	Top Assy / P3B / Standard Model	1
2	R1070	PECO Logo Decal	1

A1157 Top Assembly Exploded Parts View

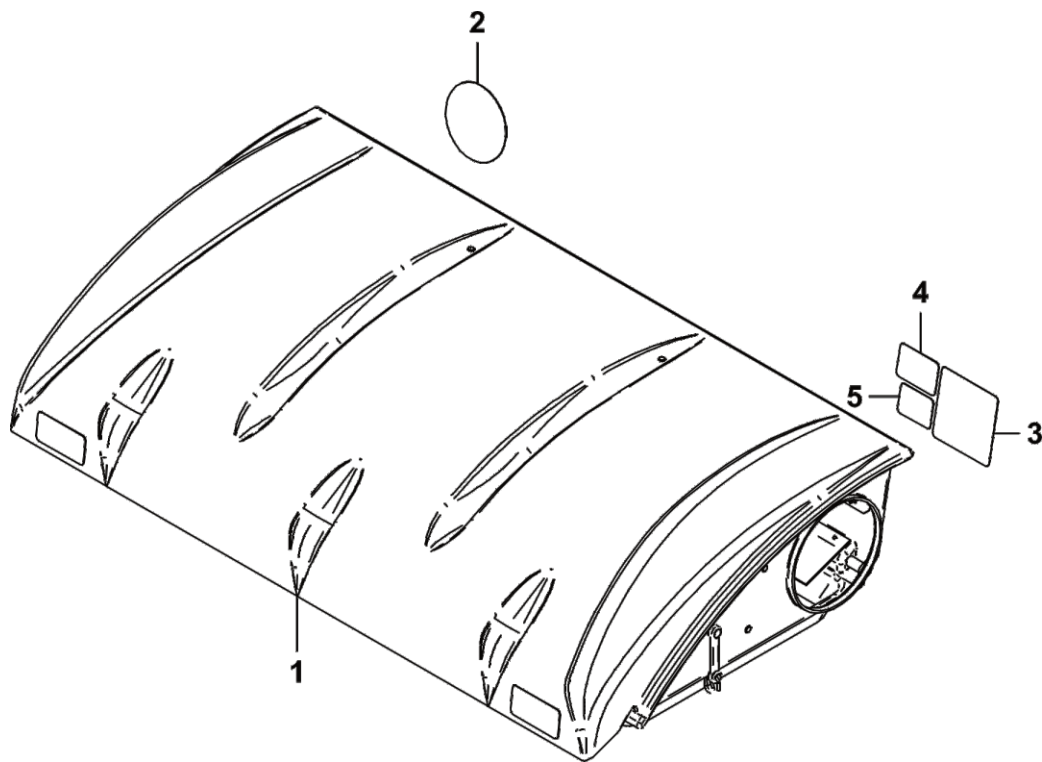

Item #	Part #	Desc.	Qty.
1	A2223	Top Assy. / P3B / Base Model	1
2	R0022	Decal / Built In The USA / Lg	1
3	R1069	Decal / Warning - Turn Off Blower	1
4	R1054	Decal / Important Check Hoses	1
5	R1051	Decal / Warning - Use Hearing Protection	1

A2223 Top Assembly Exploded Parts View

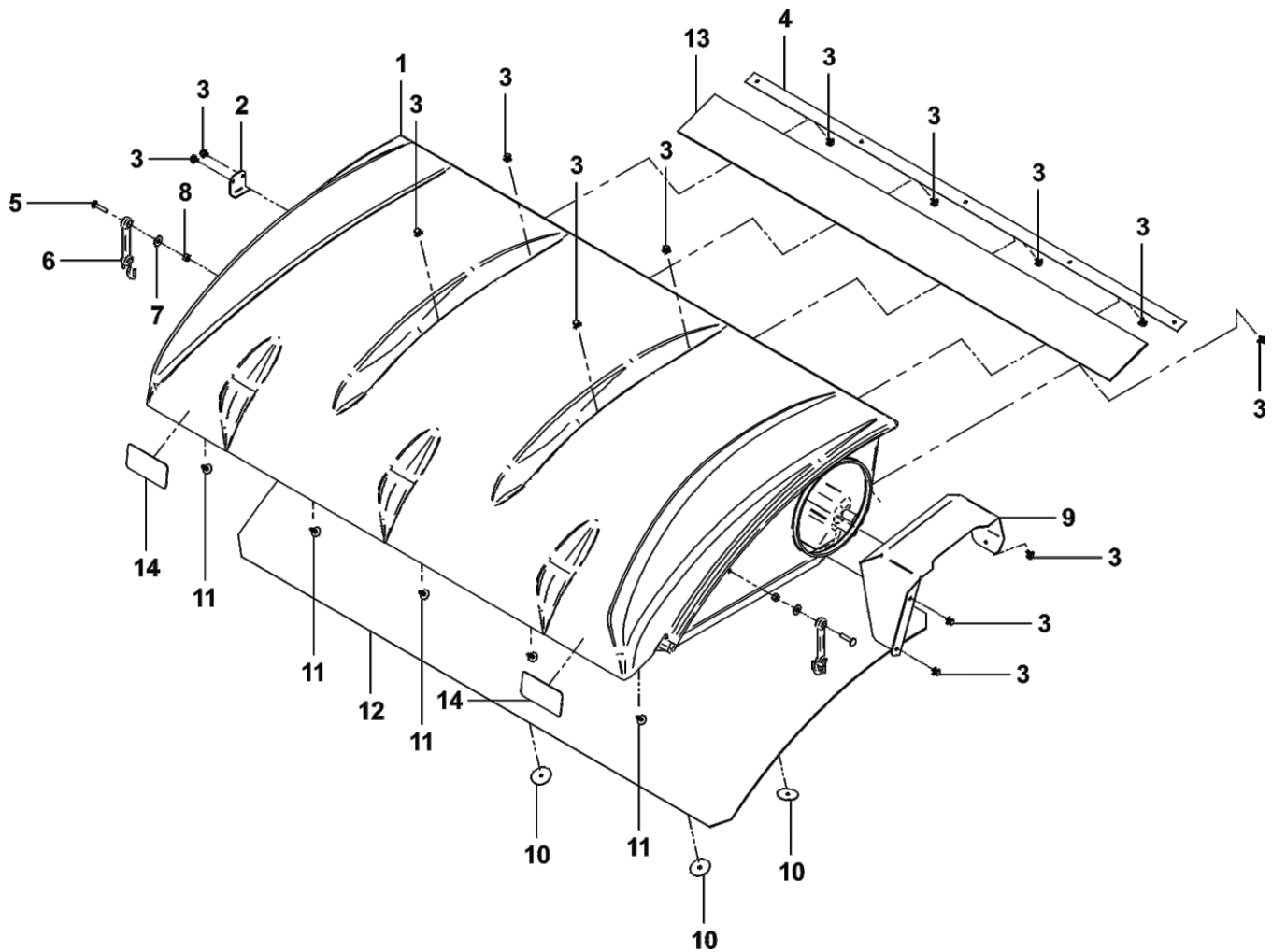

Item #	Part #	Desc.	Qty.
1	V0022	Pro 3 Bagger Top	1
2	B0676	Hinge Stop Pl.	1
3	K0114	Black Plastic Rivet	14
4	C0069	Dust Guard Brace	1
5	K1030	1/4"-20 x 1-1/4" Carriage Bolt	2
6	J4009	Short Rubber Strap w/ S-Hook	2
7	K0037	Flat Washer / 1/4" (.75 OD x .312 ID x .060 T)	2
8	K1128	1/4"-20 Nyloc Nut	2
9	C0026	Grass Deflector	1
10	K0062	Fender Washer / .230 ID x 1.500 OD / Zinc	3
11	K1265	Black Panel Retainer	5
12	V1120	Black Plastic Screen	1
13	V1118	Dust Guard	1
14	R1057	Decal / 2" x 4" Red Reflector	2

Unit Model #: 49131507 (629KD-001A)

Mower: Country Clipper

Owner's Manual: Q0574

Mower Type: Charger 8000 & 8005 series / Boss XL 9000 & 9005 series

Deck Size: 52" & 60"

Vac Type: Pro3B

Deck Type:

Drive Type: PTO-X

Revision #: 2 - PTO-X 1.5 - BS - 7/24/24

Fits Year(s): 2021-Newer



<p><input type="checkbox"/> A2328 Vac Kit</p> <ul style="list-style-type: none"> (1) HB0683 Vac Kit HW Bag (1) F0060-19 6" x 19" Upper Hose (1) A1158 Top Assy (3) B0227 Bag Ring (1) A2068 Upper Frame Assy (3) G0013 4 Cu. Ft. Collection Bags 	<p><input type="checkbox"/> A2327 Mount Kit</p> <ul style="list-style-type: none"> (1) M0316 AK81 Belt (1) B2073 Rear Frame Bracket (1) B2075 Right Frame Bracket (1) B2074 Left Frame Bracket (1) HB0839 Eng Pulley HW Bag (1) HB0827 Wiring Harness HW Bag (1) B2078 Top / Mount Arm (1) B2079 Bottom / Mount Arm (1) A2207 Mount Arm / Tube Assy (1) A2069_02 Belt Guard Assy. (1) A2061_03 Drive Assy. w/ 4-Blade Impeller (1) A2067_02 Idler Mount Assy. 	<p><input type="checkbox"/> A2159 Boot Kit</p> <ul style="list-style-type: none"> (1) B0820 Boot Plate (1) HB0453 Boot Kit HW Bag (1) B4331 Boot Rod (1) E0032A Boot 	<p><input type="checkbox"/> A2162 Quad Weight Kit</p> <ul style="list-style-type: none"> (4) Y0025 28 lb. Weight (1) B1015 Weight Bracket Clamp (1) B1063 Dual Weight Bracket Base (1) HB0713 Weight Kit HW Bag 	<p><input type="checkbox"/> A2162 Quad Weight Kit</p> <ul style="list-style-type: none"> (4) Y0025 28 lb. Weight (1) B1015 Weight Bracket Clamp (1) B1063 Dual Weight Bracket Base (1) HB0713 Weight Kit HW Bag
---	--	---	--	--

SAFETY DECALS

To promote safe operation, New PECO, Inc. supplies safety decals on all products manufactured. Damage can occur to safety decals either through shipment, use or reconditioning. Contact your local Service Center for replacement decals.



Part #: R1051
Warning - Hearing Protection



Part# R0022
Designed & Built
In The USA



Part #: R2007
Danger - Never Use Hands



Part #: R2008
Danger - Rotating Blades

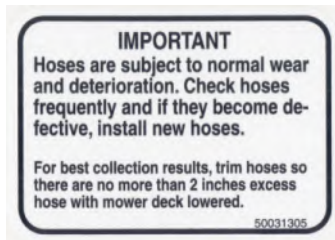

Part #: R1054
Important - Hose Wear

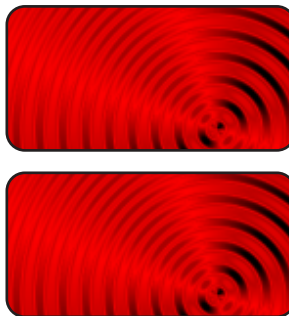

Part #: R1057 - (2)
Red Reflectors



Part #: R1069
Warning - Turn Off Blower



Part # R0024
Danger - Keep Hands
Clear



Part # R0025
Danger - Rotating
Blades

SECTION III

OPERATING INSTRUCTIONS

General Safety

Only qualified people familiar with this operator's manual and the mower's operator's manual should operate this machine.

Operation And Tips On Mowing

- A. Perform BEFORE EACH USE the maintenance list referenced in Section IV.
- B. Start mower.
- C. With the mower at high idle speed, engage the mower deck.
- D. While seated in the operator's seat, move Bagger PTO switch to the on position. With the PTO assembly engaged, you can proceed to operate the control levers of the mower.

NOTE: If the collection system does not appear to be collecting the grass clippings, disengage the deck and PTO assembly, then, engage the parking brake and turn the mower off. Check upper and lower hoses for any clogs.

To obtain the maximum effectiveness from your collection system, the tips listed below should be followed:

- * Watch your speed- Normal conditions will allow a speed of up to approximately 4 mph, but thick, heavy damp conditions will require reduced ground speed.
- * Mow with sharp blades- A sharp blade cuts cleaner.
- * Wet grass and leaves will decrease effectiveness and will increase horsepower requirements.
- * Mow at higher cutting heights- Remove and mulch no more than 2" of grass length with each mowing. (Experts recommend not cutting off more than 1/3 of the grass blade length at any given time.)
- * Mow twice, at different height settings, (high, then low), if grass is extra tall.
- * Remember that horsepower requirements will vary with the mowing conditions such as type and height of turf grass, moisture content, amount of leaves, whether the terrain is flat or hilly, etc.

Disengagement Of The PTO Assembly

- A. To disengage the PTO assembly, move Bagger PTO switch to the off position.

WARNING: DO NOT TOUCH the PTO assembly, pulleys, or the belt until the tractor is turned off.

Unloading The Collection System

NOTE: To determine when the collection bags are full, follow the following steps:

- A. Stop the forward movement of the mower.
- B. Disengage the mower deck.
- C. Disengage the PTO assembly.
- D. Engage the parking brake.
- E. Once the parking brake has been engaged, then and only then, walk behind the mower and check the collection bags by first unhooking the rubber strap with S-hook that secures the plastic top, then lift the plastic hood. Load in bags should not exceed the height of the installed bag.
- F. To remove the bags from the frame, slide bags out and turn bags over to deposit clippings.
- G. Slide empty bags back onto the frame and secure plastic top with the rubber strap with S-hook.

NOTE: Do not allow collection bags to become over-filled as potential damage may occur to your equipment. Also, be sure to clean the hood screen as needed.

SECTION IV

MAINTENANCE

Maintenance Checklist

Before each use:

1. Check blades and spindles to be sure that no foreign objects, such as wire or steel strapping bands, are wrapped around them.
2. Inspect blades for wear. Replace if necessary. If it is necessary to sharpen the blades, remove the blades from the spindles before sharpening. DO NOT sharpen blades while still attached to the mower.

3. Make sure all shields are in place and in good condition. Repair or replace any missing or damaged shields.
4. Perform lubrication per instructions.
5. Listen for abnormal sounds, which might indicate loose parts, damaged bearings, or other damage. Correct any deficiency before continuing operation.
6. With the engine off, engage the blower assembly. Check the belt tension and inspect the pulley belt for cracks or tears.
7. Check for wear or deterioration of the upper or lower hoses. If there are any portions of the hose that have been torn or worn through, replace immediately.

After Each Use:

1. Clean all debris from machine especially from the container, underneath the belt shields, and safety decals. Replace any missing or illegible decals.
2. Inspect the unit for worn or damaged components. Repair or replace before the next use. Any replacement component installed during repair shall include the component's current safety decal specified by the manufacturers to be affixed to the component.
3. Under normal usage, the bag material is subject to deterioration and wear and should therefore be frequently checked for necessary replacement. Any replacement bag should be checked to ensure compliance with the original manufacturer's recommendations or specifications.
4. Check belt for proper tension.

Lubrication

Gearbox:

NOTE: The gearbox is filled with 6.0 oz. of Mobilube HD Plus 80W-90 oil and permanently sealed. There is no need for scheduled lubrication. The oil level should only be checked if a leak is observed or if a change in gearbox noise is noticed.

Operators are recommended to check for leaks weekly. If a leak is observed, both the gasket and the seals are recommended to be replaced.

Replace the oil using 5.5 oz. of the recommended Mobilube HD Plus 80W-90 oil. Be sure to not overfill.

Blower Assembly:

NOTE: The following is for older PTO models that contain a greaseable zirc fitting. Newer models contain maintenance-free bearings and are without a greasable fitting.

1. On initial use: Grease the fitting on the blower shaft.
2. Every 25 hours of use: Re-grease the grease fitting.

NOTE: Use only white lithium based grease for lubrication of the shaft on the blower assembly.

SECTION V - PARTS & SERVICE

Parts And Service Information

Collection system owners should record the name and telephone number of their Service Center. Your Service Center will be happy to supply replacement parts, accessories, and do any service or repairs to your collection system. If for any reason your Service Center is unable to service your collection system or supply replacement parts, contact New PECO, Inc. and include the following information on the chart below.

DOCUMENT THE FOLLOWING INFORMATION FOR FUTURE REFERENCE

Unit Model Number: _____

Unit Engine Size: _____

Unit Serial Number: _____

Date of purchase: _____ / _____ / _____

Dealer/Distributor Name: _____

Address: _____ **State:** _____ **Zip:** _____

Phone Number: _____

New PECO, Inc.
10 Walden Dr | Arden, North Carolina 28704
Phone: 1-800-438-5823 | 828-684-1234
Fax: 828-684-0858
Email: peco@lawnvac.com
Website: www.lawnvac.com

TORQUE SPECIFICATIONS

Proper torque for American fasteners used on PECO equipment.
Recommended Torque in Foot Pounds (Newton Meters).*

AMERICAN Bolt Head Markings

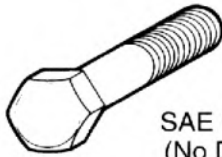

SAE Grade 2
(No Dashes)

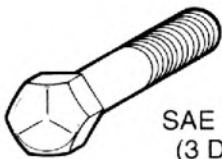

SAE Grade 5
(3 Dashes)

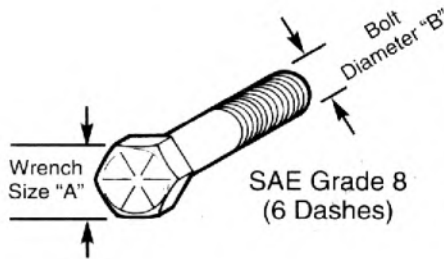

SAE Grade 8
(6 Dashes)

WRENCH SIZE (IN.) "A"	BOLT DIAMETER (IN.) "B" AND THREAD SIZE	SAE GRADE 2	SAE GRADE 5	SAE GRADE 8
7/16	1/4 - 20 UNC	6 (7)	8 (11)	12 (16)
7/16	1/4 - 28 UNF	6 (8)	10 (13)	14 (18)
1/2	5/16 - 18 UNC	11 (15)	17 (23)	25 (33)
1/2	5/16 - 24 UNF	13 (17)	19 (26)	27 (37)
9/16	3/8 - 16 UNC	20 (27)	31 (42)	44 (60)
9/16	3/8 - 24 UNF	23 (31)	35 (47)	49 (66)
5/8	7/16 - 14 UNC	32 (43)	49 (66)	70 (95)
5/8	7/16 - 20 UNF	36 (49)	55 (75)	78 (106)
3/4	1/2 - 13 UNC	49 (66)	76 (103)	106 (144)
3/4	1/2 - 20 UNF	55 (75)	85 (115)	120 (163)
7/8	9/16 - 12 UNC	70 (95)	109 (148)	153 (207)
7/8	9/16 - 18 UNF	79 (107)	122 (165)	172 (233)
15/16	5/8 - 11 UNC	97 (131)	150 (203)	212 (287)
15/16	5/8 - 18 UNF	110 (149)	170 (230)	240 (325)
1-1/8	3/4 - 10 UNC	144 (195)	266 (360)	376 (509)
1-1/8	3/4 - 16 UNF	192 (260)	297 (402)	420 (569)
1-5/16	7/8 - 9 UNC	166 (225)	430 (583)	606 (821)
1-5/16	7/8 - 14 UNF	184 (249)	474 (642)	668 (905)
1-1/2	1 - 8 UNC	250 (339)	644 (873)	909 (1232)
1-1/2	1 - 12 UNF	274 (371)	705 (955)	995 (1348)
1-1/2	1 - 14 UNF	280 (379)	721 (977)	1019 (1381)
1-11/16	1-1/8 - 7 UNC	354 (480)	795 (1077)	1288(1745)
1-11/16	1-1/8 - 12 UNF	397 (538)	890 (1206)	1444 (1957)
1-7/8	1-1/4 - 7 UNC	500 (678)	1120 (1518)	1817 (2462)
1-7/8	1-1/4 - 12 UNF	553 (749)	1241 (1682)	2013 (2728)
2-1/16	1-3/8 - 6 UNC	655 (887)	1470 (1992)	2382 (3228)
2-1/16	1-3/8 - 12 UNF	746 (1011)	1672 (2266)	2712 (3675)
2-1/4	1-1/2 - 6 UNC	870 (1179)	1950 (2642)	3161 (4283)
2-1/4	1-1/2 - 12 UNF	979 (1327)	2194 (2973)	3557 (4820)

Proper torque for metric fasteners used on PECO equipment.
Recommended Torque in Foot Pounds (Newton Meters).*

METRIC

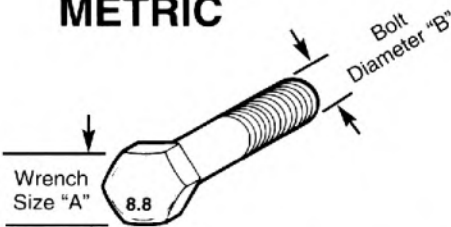

Numbers appearing on bolt heads indicate ASTM class.

WRENCH SIZE (mm) "A"	BOLT DIA. (mm) "B"	ASTM 4.6	ASTM 8.8	ASTM 9.8	ASTM 10.9
8	5	1.8 (2.4)		5.1 (6.9)	6.5 (8.8)
10	6	3 (4)		8.7 (12)	11.1 (15)
13	8	7.3 (10)		21.1 (29)	27 (37)
16	10	14.5 (20)		42 (57)	53 (72)
18	12	25 (34)	74 (100)	73 (99)	93 (126)
21	14	40 (54)	118 (160)	116 (157)	148 (201)
24	16	62 (84)	167 (226)	181 (245)	230 (312)
30	20	122 (165)	325 (440)		449 (608)
33	22		443 (600)		611 (828)
36	24	211 (286)	563 (763)		778 (1054)
41	27		821 (1112)		1138 (1542)
46	30	418 (566)	1119 (1516)		1547 (2096)

*Use 75% of the specified torque value for plated fasteners. Use 85% of the specified torque values for lubricated fasteners.

Troubleshooting

2017 (v1.0)

Collection System Performance

Problem	Possible Cause	Corrective Action
Abnormal Vibration	<ul style="list-style-type: none"> • Cutting blades are bent or unbalanced • Loose blower pulley or pulley assembly • Impeller blade out of balance 	<ul style="list-style-type: none"> • Install new cutting blade • Tighten the pulley • Contact dealer to replace
Reduced collection system performance	<ul style="list-style-type: none"> • Low engine speed • Plugged screen • Loose belt • Full collection bags 	<ul style="list-style-type: none"> • Always operate collection system at full throttle • Remove debris, leaves, or grass clippings from the screen • Replace/tighten belt • Empty the collection bags
Blower and hoses plugging too frequently	<ul style="list-style-type: none"> • Collection bags are too full • Low engine speed • Grass is too wet • Grass is too long • Ground speed is too fast • Worn belt • Loose belt 	<ul style="list-style-type: none"> • Dump more frequently • Always operate collection system at full throttle • Cut grass when it is dry • Cut the grass several times • Drive slower at full throttle • Replace belt • Adjust the pulley and tighten belts
Debris blowout	<ul style="list-style-type: none"> • Collection bags are too full • Plug/clog in the collection system • Ground speed is too fast 	<ul style="list-style-type: none"> • Dump more frequently • Clean the collection system • Drive more slowly at full throttle
Impeller doesn't rotate freely	<ul style="list-style-type: none"> • Plug in the blower housing • Worn impeller blade • Shaft bearings bad/failing 	<ul style="list-style-type: none"> • Clean the blower housing • Contact dealer to replace • Contact dealer to replace



New PECO, Inc.
10 Walden Dr | Arden, North Carolina 28704
Phone: 1-800-438-5823 | 828-684-1234
Fax: 828-684-0858
Email: peco@lawnvac.com
Website: www.lawnvac.com