



# PTO-X DRIVEN - GRASS COLLECTION SYSTEM

Model # 38131510

**Dixie Chopper Eagle HP Pro3 Bagger**

**Jacobsen ZT1000**

Model Year: 2020

Deck Sizes: 60", 66" & 72"



## OPERATOR'S MANUAL

ASSEMBLY • OPERATION • MAINTENANCE

# GRASS COLLECTION SYSTEM

## TABLE OF CONTENTS

SECTION	PAGE	SECTION	PAGE
Safety	2	Bag Assembly Installation	22
Safety Alert Symbols	3	Wiring Harness Installation	23-24
Warranty	4	Length of Hose Adjustment	25
I INTRODUCTION AND DESCRIPTION	5	Upper Hose Installation	25
Introduction	5	Lower Hose To Blower Cone Installation	25
Description	5	Lower Hose To Boot Installation	25
II INSTALLATION FOR USE	6	Impeller Blade Removal/Replacement	26
Preparation Of Mower	6	Weight Kit Installation	27-29
Left Mount Plate Installation	7	Exploded Views & Parts List	30-40
Right Mount Plate Installation	7	Overall Parts List	41
Rear Mount Plate Installation	8-9	Safety Decals	42
PTO Mount Plate Installation	10	III OPERATING INSTRUCTIONS	43
Mount Arm/Tube Assy Installation	11	General Safety	43
Lower Mount Tube Installation	12	Operation & Tips On Mowing	43
Upper Frame Assy Installation	12	Disengagement Of The PTO Assembly	43
PTO Drive Assy	13-14	Unloading The Collection System	43
Drive Assy & Belt Installation	15	IV MAINTENANCE	43-44
Belt Tension Adjustment	16-18	Maintenance Checklist	43
Boot Kit Installation	19	Lubrication	44
Top Assembly To Upper Frame Assy Installation	20	V PARTS AND SERVICE	44
Inlet Installation	20	Parts And Service Information	44
Hinge Kit Assembly Installation	21	Torque Specifications	45
Even Bag Fill Adjustment	21	Troubleshooting	46
Bag Assembly	22		

## SAFETY

1. Read the operator's manual carefully and familiarize yourself with the proper use of your attachment. Do not allow anyone who is not acquainted with the Safety Instructions to use your attachment.
2. Know the controls and how to stop them quickly. **READ THE OPERATOR'S MANUAL!**
3. Do not allow children to operate the machine. Do not allow adults to operate it without proper instruction.
4. Be especially watchful of children and pets entering into the area while operating.
5. Keep your eyes and mind on your machine while mowing or operating your attachment. Don't let others distract you.
6. Do not attempt to operate your machine when not in the driver's seat.
7. Always shut off blades and engine when emptying the container.
8. Stop machine, shut off deck attachment, set parking brake, shut off engine and remove ignition key before removing clogs, removing or replacing hose, boot, blower cone, or performing any maintenance.
9. Mow across the face of slopes (not more than 10 degrees); never up and down the face.
10. It is recommended that the container be emptied when half full while operating on slopes. Start mowing on slopes when the container is empty.
11. Inspect your lawn and remove any foreign objects before mowing. Never deliberately run the mower across any foreign object.
12. Wear hearing protection.
13. Wear eye protection to prevent debris from getting into your eyes.

# SAFETY

**WARNING!** NEVER operate the mower unless the discharge guard and either the deflector assembly or the vacuum collector adapter are fastened securely in place.

**WARNING!** Do not work around the mower deck boot or the blower area until you are certain that the mower blades and the blower impeller have stopped rotating.

**WARNING!** To avoid serious injury, perform maintenance on the vacuum collector; **ONLY AFTER STOPPING THE MOWER'S ENGINE AND WAITING FOR ALL MOVING PARTS TO COME TO A COMPLETE STOP.** Set the parking brake. Always remove the ignition key before beginning maintenance.

**WARNING!** For your own personal safety, **ALWAYS mow ACROSS the face of slopes and NEVER UP and DOWN the face. NEVER attempt to mow excessively steep slopes, and use caution when turning on any slope.**

## Safety Alert Symbol



This Safety Alert Symbol means: **“ATTENTION! BECOME ALERT! YOUR SAFETY IS INVOLVED!”**

This symbol is used to call attention to safety precautions that should be followed by the operator to avoid accidents. When you see this symbol, carefully read the message that follows and heed its advice. Failure to comply with safety precautions could result in death or serious bodily injury.

## Safety Signs

The signal words **DANGER**, **WARNING**, and **CAUTION** are used on the equipment safety signs. These words are intended to alert the viewer to the existence and the degree of hazard seriousness.



White letters on **RED**

This signal word indicates a potentially hazardous situation which, if not avoided, will result in death or serious injury.



Black letters on **ORANGE**

This signal word indicates a potentially hazardous situation which, if not avoided, could result in death or serious injury.

It may also be used to alert against unsafe practices.



Black letters on **YELLOW**

This signal word indicates a potentially hazardous situation which, if not avoided, will result in minor or moderate injury.

It may also be used to alert against unsafe practices.

# PECO LIMITED WARRANTY FOR NEW PRODUCTS

New PECO, Inc. extends the following warranties to the ORIGINAL PURCHASER of each New PECO, Inc. consumer product purchased from one of our Dealers or directly from New PECO, Inc., subject to the following limitations:

## **A. ITEMS COVERED UNDER WARRANTY**

1. **PRODUCT WARRANTY** – Any part or parts which are deemed defective in material or workmanship, as delivered to the original purchaser, will either be repaired or replaced, as New PECO, Inc. elects, without charge for parts or labor, if the defect appears within 12 months from the date of purchase of the product to the Original Purchaser.
2. **PARTS REPLACED DURING WARRANTY** – Any New PECO, Inc. part which is furnished in performance of this warranty and is defective in material or workmanship as delivered to the purchaser will be repaired or replaced, as New PECO, Inc. elects, before the expiration of the original warranty period.

## **B. WARRANTY DISTINCTIONS**

1. **RESIDENTIAL** - Products put to a personal use around a single household or residence are considered Residential. Products designated as “Residential” are warranted for 12 months from the date of purchase of the product, to the ORIGINAL PURCHASER with proof of purchase, when used for or in residential applications.
2. **COMMERCIAL** – Products put to any business use (agricultural, commercial or industrial) or used at multiple locations are considered Commercial. Products designated as “Commercial” are warranted for 12 months from the date of purchase of the product, to the ORIGINAL PURCHASER with proof of purchase, when used for or in commercial applications. Products designated as “Residential” are warranted for 90 days from the date of purchase of the product, to the ORIGINAL PURCHASER with proof of purchase, when used for or in Commercial applications.
3. **RENTAL** – Products used for Rental or Lease Purposes are warranted for 45 days from date of purchase of the product, to the ORIGINAL PURCHASER with proof of purchase, when used for or in a rental business.

## **C. ITEMS NOT COVERED BY NEW PECO WARRANTY**

1. **ENGINES & BATTERIES:** Engines and Batteries attached to New PECO, Inc. products are covered under their respective separate manufacturer warranties and those companies must be contacted directly to file a warranty claim. Briggs & Stratton: [https://www.briggsandstratton.com/na/en\\_us/support/warranty.html](https://www.briggsandstratton.com/na/en_us/support/warranty.html)
2. **UNAPPROVED ALTERATION OR MODIFICATION:** All obligations of New PECO, Inc. under this warranty shall be terminated if products are altered or modified in any way not approved by New PECO, Inc.
3. **ACCIDENTS & NORMAL MAINTENANCE:** This warranty covers ONLY manufacturers defective material and workmanship. It does not cover depreciation or damage caused by normal wear & tear, accident, improper maintenance, misuse or abuse of products. New PECO, Inc. products must be operated and maintained in accordance with the instructions furnished in the manuals. The cost of normal maintenance and normal replacement of service items such as belts, cutting blades, hoses, bags, etc., which are not defective shall be paid for by the purchaser.
4. **NO SERVICE CENTER WARRANTY:** The selling Service Center/Dealer makes no warranty on his own on any item warranted by New PECO, Inc. unless he delivers to purchaser a separate written warranty certificate specifically warranting the item. The Service Center or Dealer has no authority to make any representation or promise on behalf of New PECO, Inc. or to modify the terms of the original warranty in any way.
5. **NO REPRESENTATIONS ADDITIONAL WARRANTIES, DISCLAIMER:** Neither New PECO, Inc. nor any company affiliated with New PECO, Inc. makes any warranties, representations or promises as to the quality of performance of its products other than those set forth herein. Except as described above, New PECO, Inc. makes no other warranties **AND SPECIFICALLY DISCLAIMS ANY AND ALL IMPLIED WARRANTIES OF FITNESS AND MERCHANTABILITY.**
6. **REMEDIED EXCLUSIVE:** The only remedies the purchaser has in connection with the breach or performance of any warranty on New PECO, Inc. consumer products are set forth above. In no event will New PECO, Inc. be liable for special incidental or consequential damages.

Warranty service is available through your local authorized service dealer or distributor. If you do not know the dealer or distributor in your area, search by your zip code on [www.lawnvac.com](http://www.lawnvac.com) or contact our Sales Department at New PECO, Inc. 800-438-5823 or email [Sales@lawnvac.com](mailto:Sales@lawnvac.com).

# Section I - INTRODUCTION AND DESCRIPTION

## Introduction

We are pleased to have you as a PECO customer. Your collection system has been designed to give you a low maintenance, simple, and effective way to collect the grass clippings from your mower. The manuals are provided to give you the necessary instructions to properly mount, operate and maintain the collection system on your mower. Please read this manual thoroughly. Understand what each control is for and how to use it. Observe all safety decal precautions on the machine and noted throughout the manual.

**NOTE:** All references made to right, left, front, rear, top or bottom are as viewed from the normal operator's position on the mower.

## Description

The grass collection system is designed for turf maintenance where there is a need to collect the grass clippings as the mower cuts the turf. It is also used for picking up leaves in pre-season and post-season clean-up. The blower, mounted on the right side of the unit, uses a belt and gearbox system from the engine PTO shaft. Drive train protection comes through belt slippage. The blower draws grass clippings from the discharge area of the cutting deck back to the collection bags at the rear portion of the mower frame. The operator can engage the blower with a push of the over-center linkage on the right side of the unit. Once the bags are full with clippings, they can be easily released for dumping.



## Section II - INSTALLATION FOR USE

### Preparation Of Mower

**NOTE:** The mower deck PTO belt must be removed from the electric clutch before continuing with the installation. Refer to your mower's owner's manual for instructions on PTO belt removal.

From the underside of the engine, disconnect the wiring harness attached to the electric clutch. Remove the bolt and electric clutch from the mower. Refer to Figure A.

Figure A

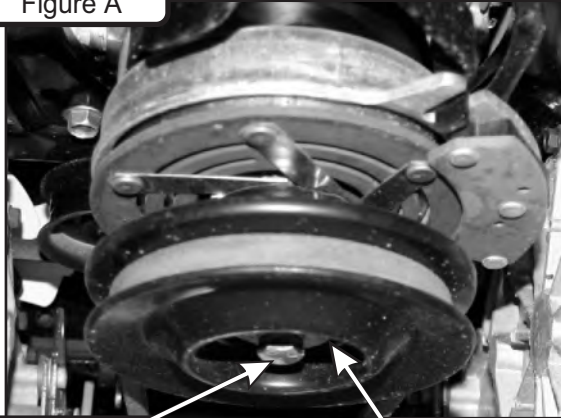

Remove Bolt

D-Drive Spacer

Upon removal of clutch determine if your mower is equipped with a D-drive spacer. If so, then proceed to Figure B. If your mower is equipped with bolt, fender and lock washer without D-drive spacer proceed to Figure C. Remove the D-drive spacer using an arbor press or equivalent. On removal, adjacent bearing OUTER race must be supported or bearing damage may occur. Refer to Figure B.

Figure B

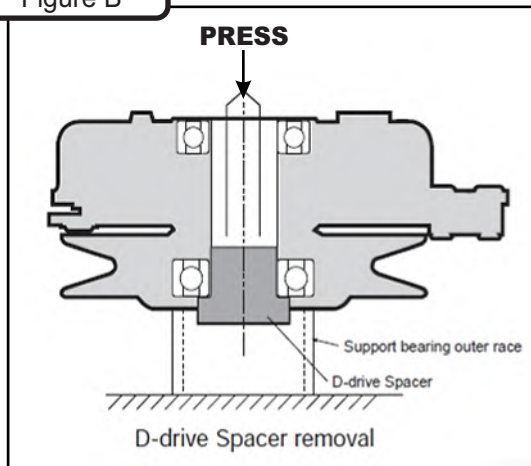
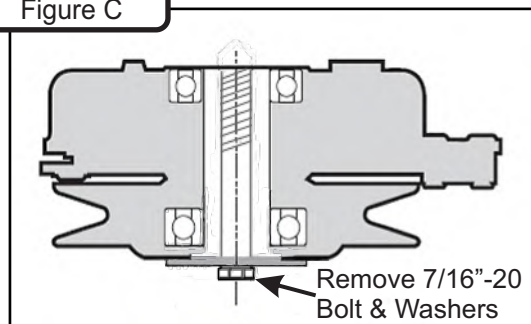
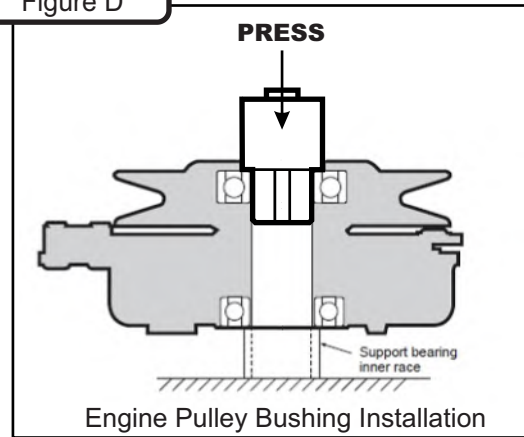

Figure C



The engine pulley assembly must be installed using an arbor press or equivalent. During installation, opposite bearing inner race must be supported or bearing damage may occur. Refer to Figure D.

Figure D



Once the Engine Pulley Bushing is installed, reattach the clutch assembly & deck PTO belt to the mower and then review Figure E.

Figure E

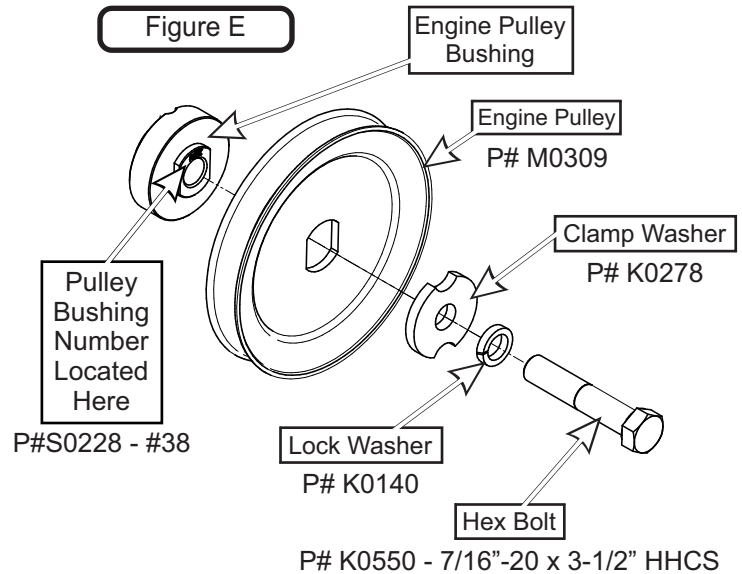

To assemble and fasten the Engine Pulley, align the Engine Pulley Bushing to the mower's clutch pulley and fasten using (1) Clamp Washer, (1) Lock Washer, and (1) Hex Bolt. Torque the bolt to 55 ft./lbs. The added pulley will power the collection system and should resemble Figure F when installed.

Figure F

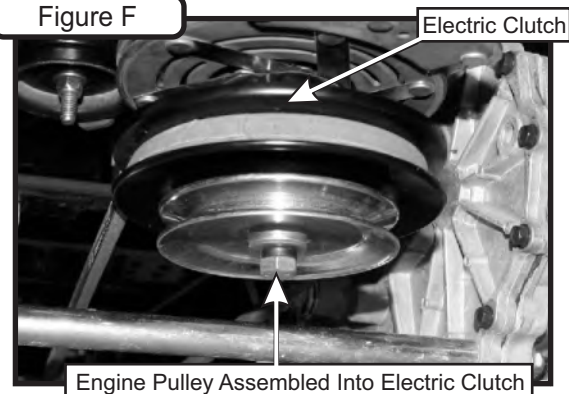

## Left Mount Plate Installation

Before installing the Left Mount Plate (Item #1), remove the hardware fastening the lower left side of the mower's rear bumper to reveal (2) bolt holes.

Next, align the bottom (2) left bolt holes of the Left Mount Plate to the ones on the lower left side of the mower's rear bumper. Secure the Left Mount Plate to mower by using (2) 3/8"-16 x 1-1/4" Carriage Bolts (Item #2) and (2) 3/8"-16" Ny-Flange Lock Nuts. Refer to Figure A below.

Figure A

Item #	Part #	Desc.	Qty.
1	B1090	Left Mount Plate	1
2	K1183	Carriage Bolt 3/8"-16 x 1-1/4"	2
3	K2038	Ny-Flange Lock Nut 3/8"-16	2

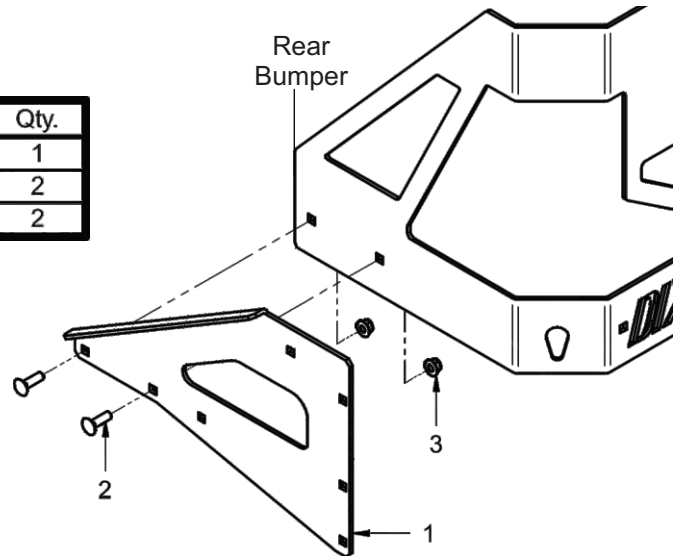

## Right Mount Plate Installation

Before installing the Right Mount Plate (Item #1), remove the hardware fastening the lower right side of the mower's rear bumper to reveal (2) bolt holes. Then remove the hardware from the lower bolt hole of the right side of the ROPS to reveal (1) bolt hole.

Next, align the bottom (2) right bolt hole of the Right Mount Plate to the ones on the lower right side of the mower's rear bumper and align the top right bolt hole of the Right Mount Plate to the one on the ROPS, refer to Figure B below. Secure the Right Mount Plate to the mower by using (1) 1/2"-13 x 3-1/2" Hex Bolt (Item #2), (1) 1/2" Flat Washer (Item #3), (1) 1/2"-13 Flange Nut (Item #4), (2) 3/8"-16 x 1-1/4" Carriage Bolts (Item #5) and (2) 3/8"-16" Ny-Flange Lock Nuts (Item #6). Refer to Figure B below.

Leave the (2) 3/8"-16 x 1-1/4" Carriage Bolt and (2) 3/8"-16 Ny-Flange Lock Nuts relatively loose for the installation of the PTO Mount Arm (Page 10).

Note: Some parts and part features have been hidden from view for visual clarity.

Figure B

Item #	Part #	Desc.	Qty.
1	B1081	Right Mount Plate	1
2	K1237	1/2"-13 x 3-1/2" HHCS GR5	1
3	K0055	Flat Washer 1/2" / 1.383 OD x .560 ID x .120 T	1
4	K1246	Flange Nut 1/2"-13	1
5	K1183	Carriage Bolt 3/8"-16 x 1-1/4"	2
6	K2038	Ny-Flange Lock Nut 3/8"-16	2

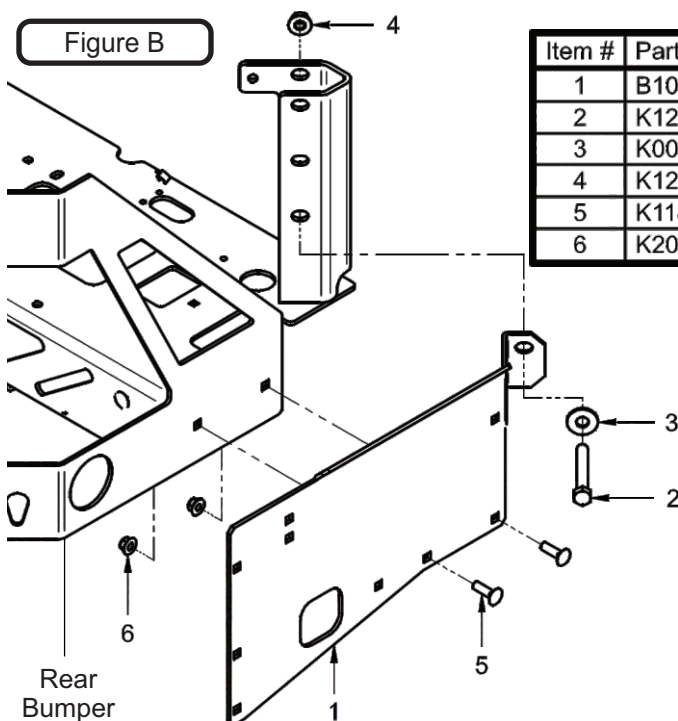

## Rear Mount Kit Assembly Installation

Before the installation of the Rear Mount Plate (Item #1), remove the existing hardware underneath the rear bumper around the hitch receiver.

Position the Rear Mount Plate to the mower's rear bumper and align the bottom (2) bolt holes located on the bottom tab of the Rear Mount Plate to those on the mower's rear bumper, see Figure A.

Secure the Rear Mount Plate, relatively loose, using (2) 3/8"-16 x 1-1/2" Carriage Bolts (Item #2), (2) Spacers (Item #3) and (2) 3/8"-16 Ny-Flange Lock Nuts (Item #4). Refer to Figure A below.

Note: Some parts and part features have been hidden from view for visual clarity.

Figure A

Item #	Part #	Desc.	Qty.
1	B1084_01	Rear Mount Plate / Eagle HP	1
2	K1337	Carriage Bolt 3/8"-16 x 1-1/2"	2
3	S3287	Spacer .437 ID x .750 OD x .250 T	2
4	K2038	Ny-Flange Lock Nut 3/8"-16	2

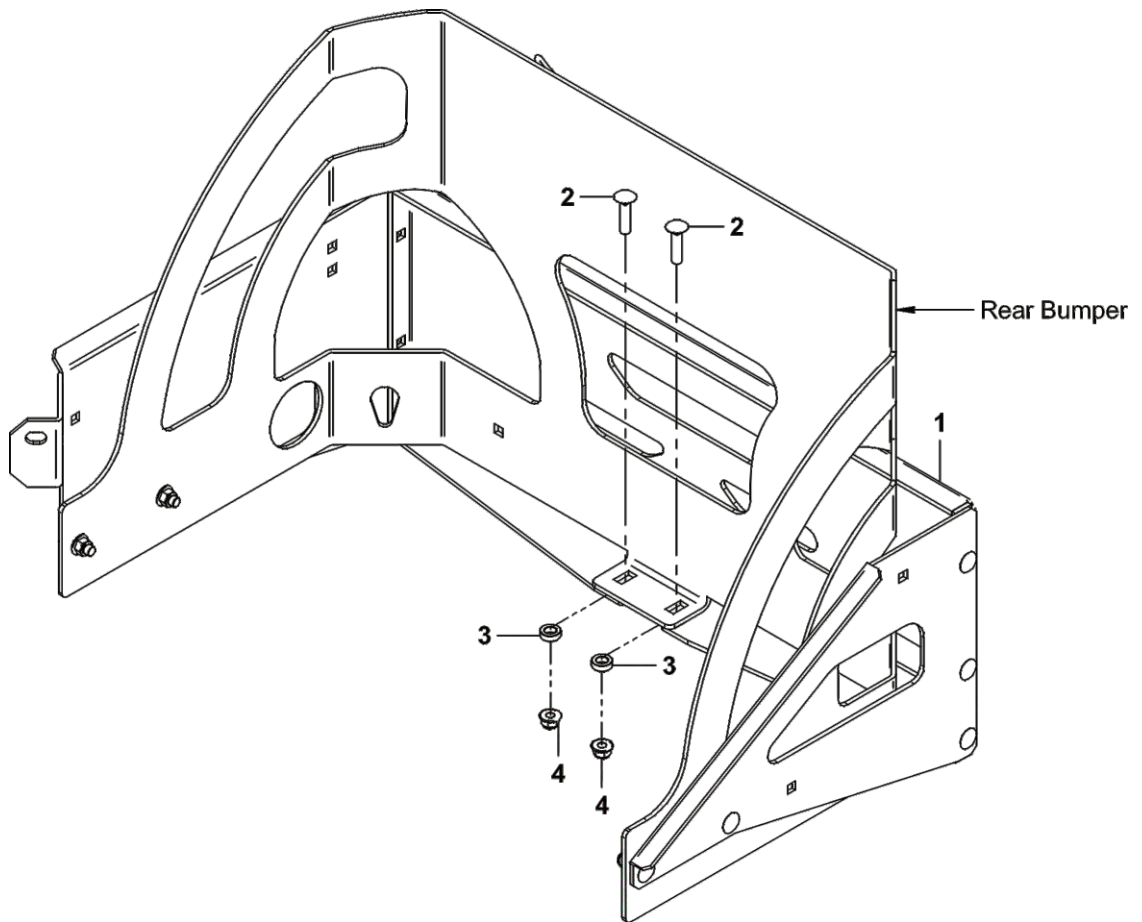



## Rear Mount Kit Assembly Installation (cont.)

Next, align the side bolt holes of the Rear Mount Plate to those on the Left and Right Mount Plate.

Secure the Rear Mount Plate to the Left Mount Plate using (3) 3/8"-16 x 1" Carriage Bolts (Item #2) and (3) 3/8"-16 Ny-Flange Lock Nuts (Item #3). Secure the Rear Mount Plate to the Right Mount Plate Using (1) 3/8"-16 x 1" Carriage Bolt (Item #1) and (1) 3/8"-16 Ny-Flange Lock Nut (Item #3). Refer to Figure B.

Once the Rear Mount Plate is fully secured, tighten all hardware at this time.

Note: Some parts and part features have been hidden from view for visual clarity.

Figure B

Item #	Part #	Desc.	Qty.
1	B1084_01	Rear Mount Plate / Eagle HP	1
2	B1081	Right Mount Plate	1
3	B1090	Left Mount Plate	1
4	K1182	Carriage Bolt 3/8"-16 x 1"	4
5	K2038	Ny-Flange Lock Nut 3/8"-16	4

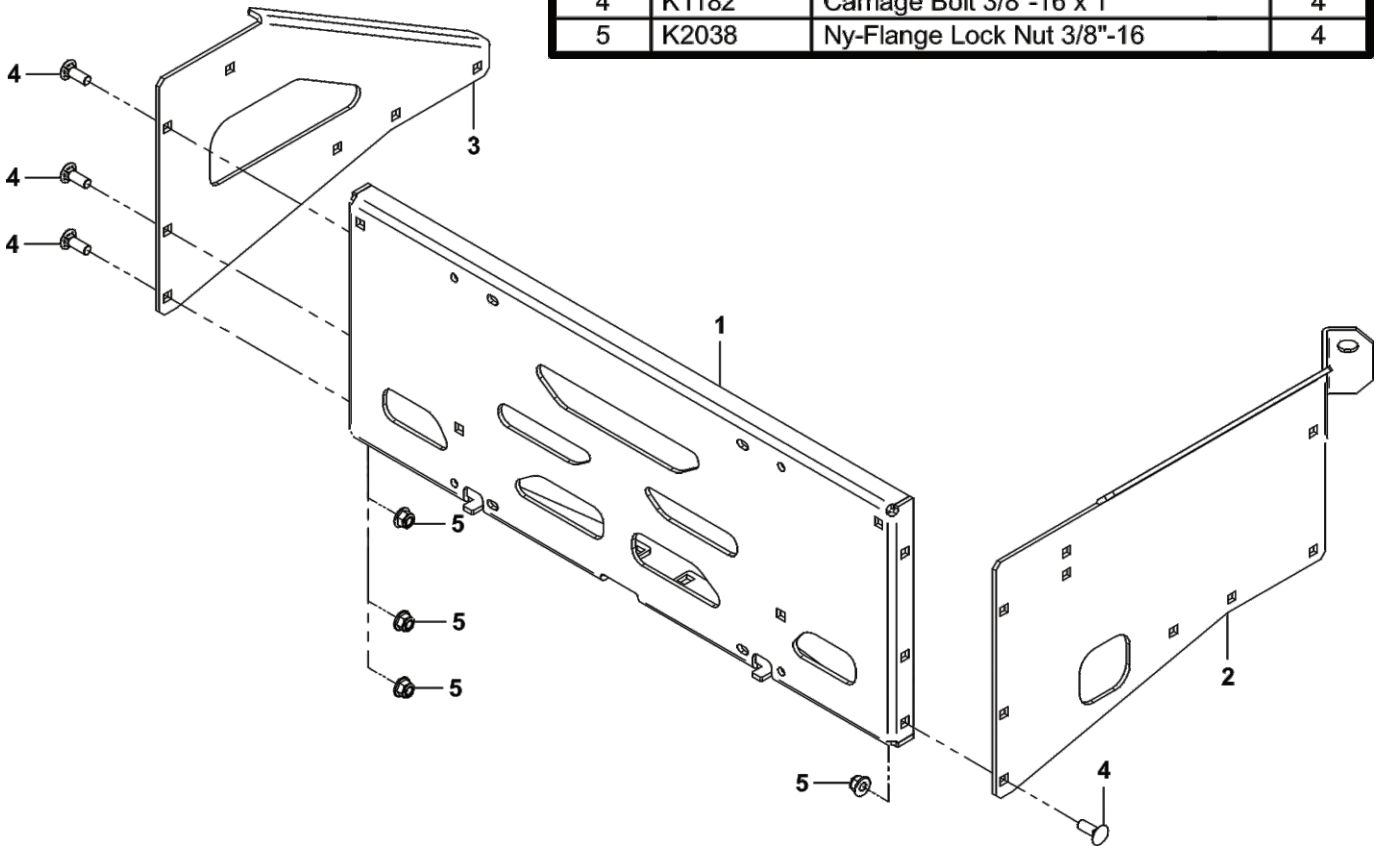

## PTO Mount Plate Installation

Before installing the Lower Mount Plate (Item #1) loosen and remove the (2) bottom pair of hardware previously used to secure the bottom right of the Right Mount Plate, see Figure A. To install the Lower PTO Mount Plate (Item #1), Align the row of carriage bolt holes of those of the Lower PTO Mount Plate located on the bottom of the Right Mount Plate. Secure the Lower PTO Mount Plate by using (1) 3/8"-16 x 1-1/2" Carriage Bolt (Item #2), (2) 3/8"-16 x 1-1/4" Carriage Bolt (Item #3) and (3) 3/8"-16 Ny-Flange Lock Nuts (Item #4). Refer to Figure A.

Note: Some parts and part features have been hidden from view for visual clarity with the figures below.

Figure A

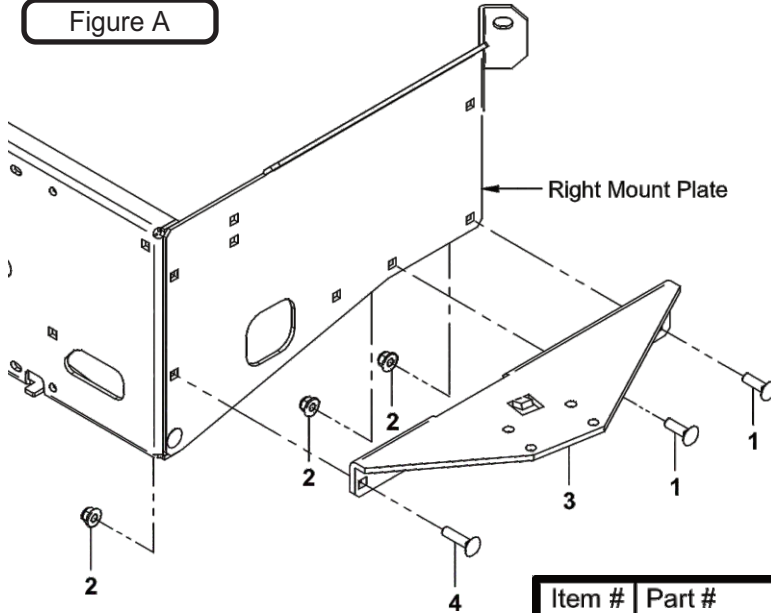

Item #	Part #	Desc.	Qty.
1	K1183	Carriage Bolt 3/8"-16 x 1-1/4"	2
2	K2038	Ny-Flange Lock Nut 3/8"-16	3
3	B1082	Lower PTO Mount Plate	1
4	K1337	Carriage Bolt 3/8"-16 x 1-1/2"	1

To Install the Top Mount Plate (Item #1), align the row of carriage bolt holes to those located on the top of the Right Mount Plate, see Figure B. Secure the Upper PTO Mount Plate by using (1) 3/8"-16 x 1-1/2" Carriage Bolt (Item #2), (2) 3/8"-16 x 1-1/4" Carriage Bolt (Item #3) and (3) 3/8"-16 Ny-Flange Lock Nuts (Item #4). Refer to Figure B.

Figure B

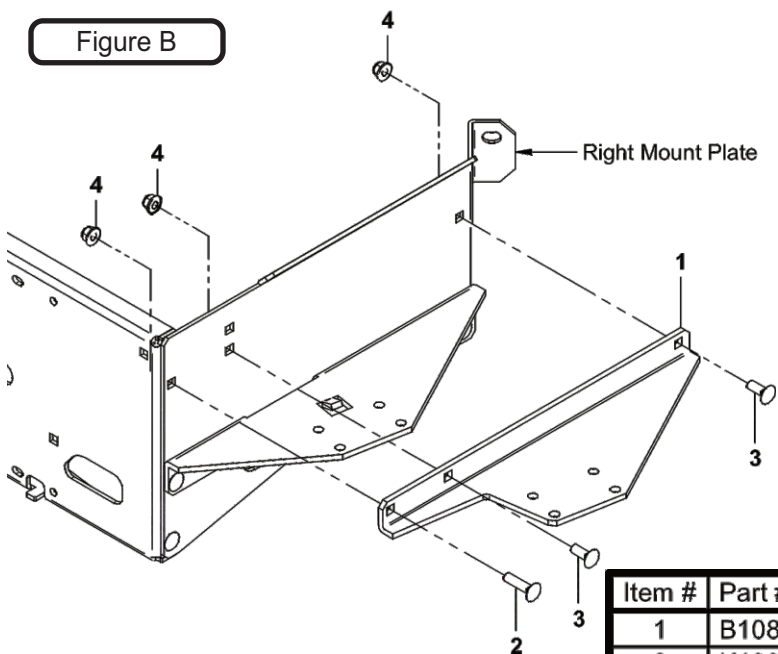

Item #	Part #	Desc.	Qty.
1	B1083	Upper PTO Mount Plate	1
2	K1337	Carriage Bolt 3/8"-16 x 1-1/2"	1
3	K1182	Carriage Bolt 3/8"-16 x 1"	2
4	K2038	Ny-Flange Lock Nut 3/8"-16	3

## Mount Arm / Tube Assembly Installation

Position and place the Receiver Tube Assy / Mount Arm (Item #1) between the Upper PTO Mount Plate (Item #2) and Lower PTO Mount Plate. Make sure the back of the Receiver Tube Assy is resting against the bottom stop tab of the Lower PTO Mount Plate, see Figure B.

Secure the Receiver Tube Assy / Mount Arm to the Upper and Lower PTO Mount Plate by using (4) Grade 5 3/8"-16 x 3-1/2" HHCS (Item #2) and (4) 3/8"-16 Ny-flange Lock Nuts (Item #3). Refer to Figure A.

Note: Some part features have been hidden for visual clarity.

Figure A

Item #	Part #	Desc.	Qty.
1	A2207	Receiver Tube Assy. / Mount Arm	1
2	B1083	Upper PTO Mount Plate	1
3	B1082	Lower PTO Mount Plate	1
4	K1200	3/8"-16 x 3.5" HHCS G5	4
5	K2038	Ny-Flange Lock Nut 3/8"-16	4

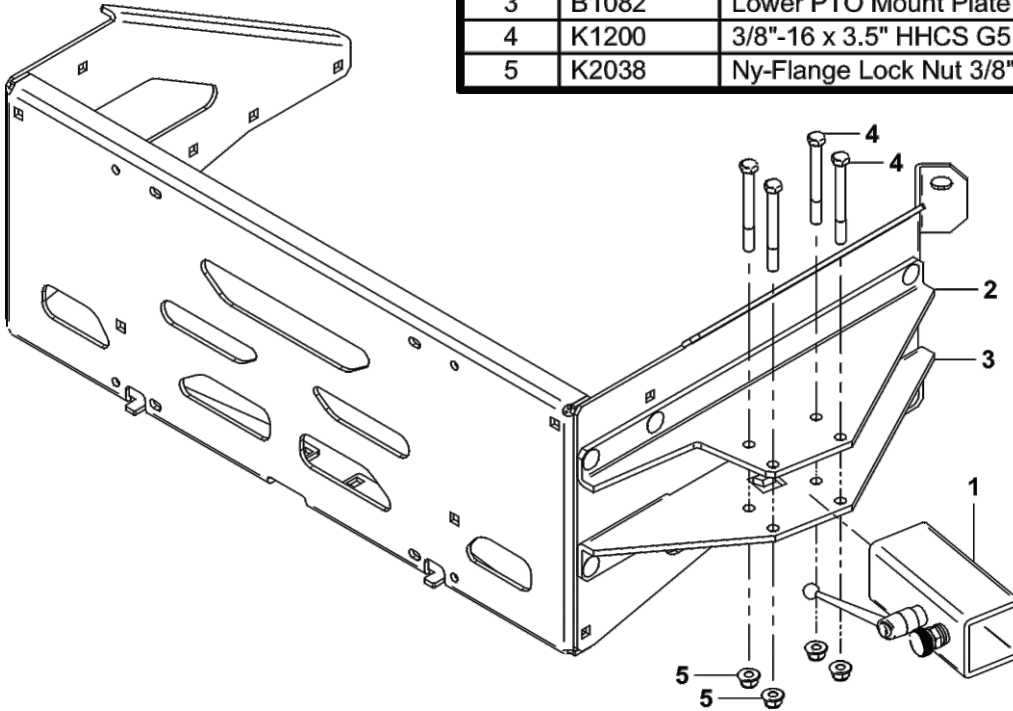
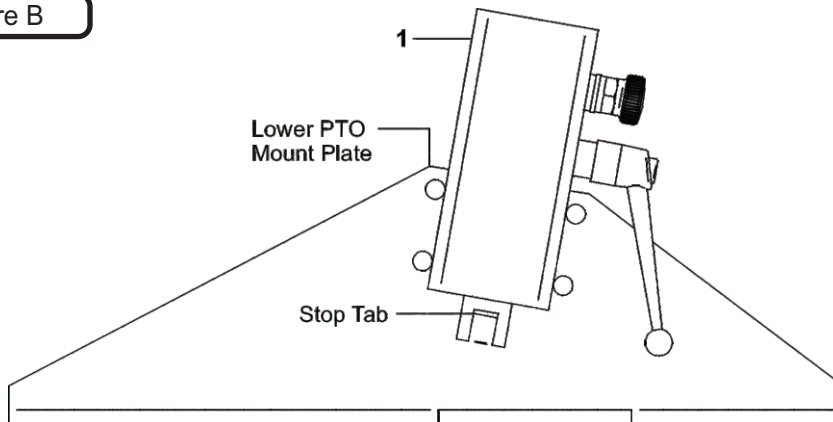

Figure B



## Lower Mount Tube Installation

Secure (2) Lower Mount Tubes (Item #1) to the Rear Lower Frame Bracket using (2) 5/16"-18 x 2" x 2-1/2" U-Bolt (Item #2) and (4) 5/16"-18 Ny-Flange Locknuts (Item #3) PER TUBE. Allow the Lower Mount Tubes to rest on the lower tab of the Rear Frame Bracket. Refer to Figure A.

Note: Some parts and part features have been hidden from view for visual clarity.

Figure A

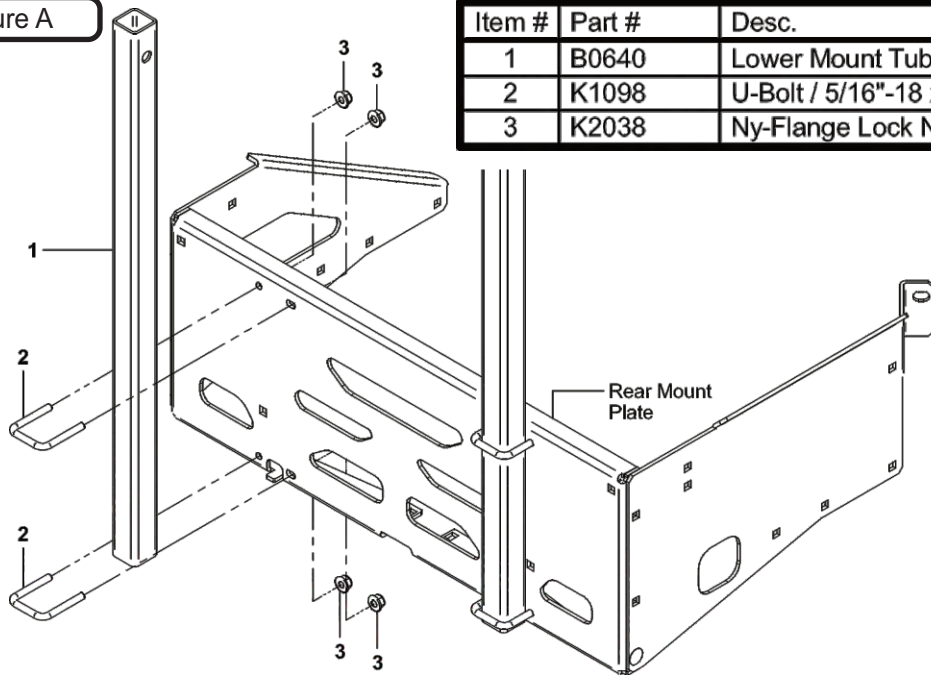

Item #	Part #	Desc.	Qty.
1	B0640	Lower Mount Tube / 29"	2
2	K1098	U-Bolt / 5/16"-18 x 2-3/8" x 1-3/4"	4
3	K2038	Ny-Flange Lock Nut 3/8"-16	8

## Upper Frame Assembly Installation

Slide the Upper Frame Assembly down onto the Lower Mount Tubes and secure using (2) Clevis Pins (Item #2) and (2) Rue Ring Cotter Pin Clips (Item #3). Refer to Figure B.

Note: Some parts and part features have been hidden from view for visual clarity.

Figure B

Item #	Part #	Desc.	Qty.
1	A2068	Upper Frame Assembly P3B Generic Gen 2	1
2	K0133	Clevis Pin 1/2" x 2-1/2"	2
3	K1437	Rue Ring Cotter Pin	1

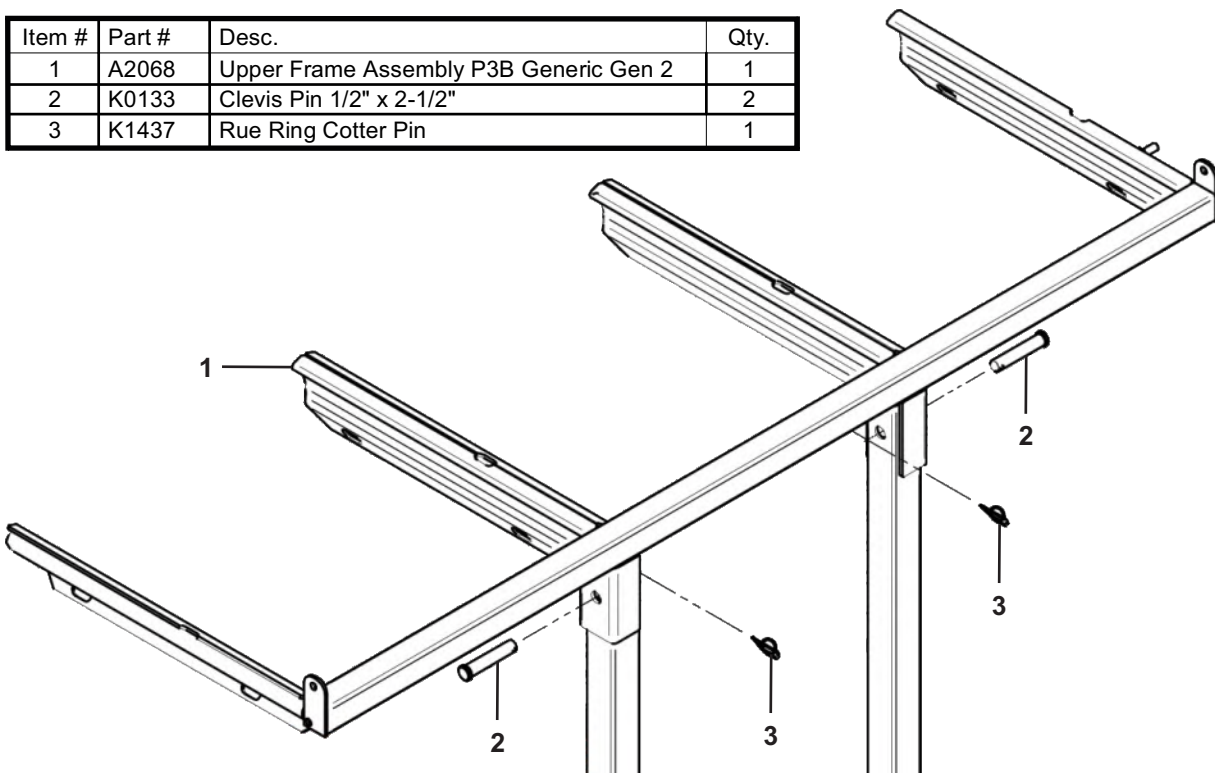

## PTO Drive Assembly

Once the Mount Arm Assembly is installed and secured to the mower, assemble the Drive Assembly P#(A2061\_02), Belt Guard Assembly P#(A2069\_02) & Idler Mount Assembly P#(A2067\_02).

First, attach the Belt Guard Assembly P#(A2069\_02) to the Drive Assembly P#(A2061\_03) using (2) 1/4"-20 x 5/8" Carriage Bolts P#(K1010) and (2) 1/4"-20 Ny-Flange Lock Nuts P#(K2014). Refer to Figure A. **Leave Bolts Loose.**

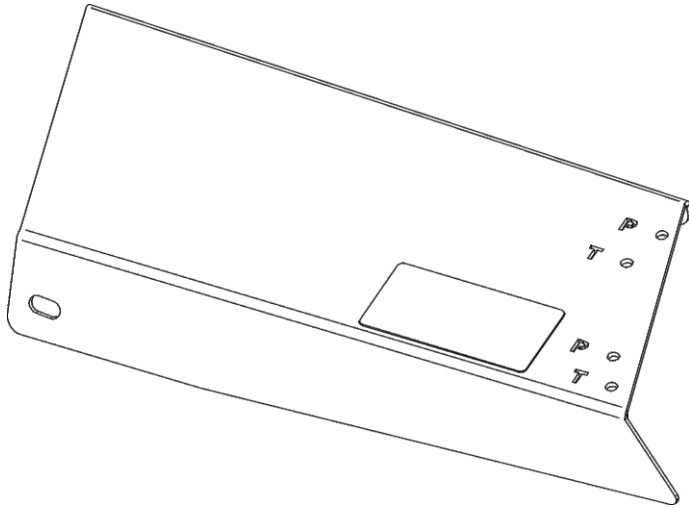

### BELT GUARD ASSY. HOLES

Notice Marked Holes Below;  
For This Installation, Use Holes  
Marked With The Letter 'P'

Figure A

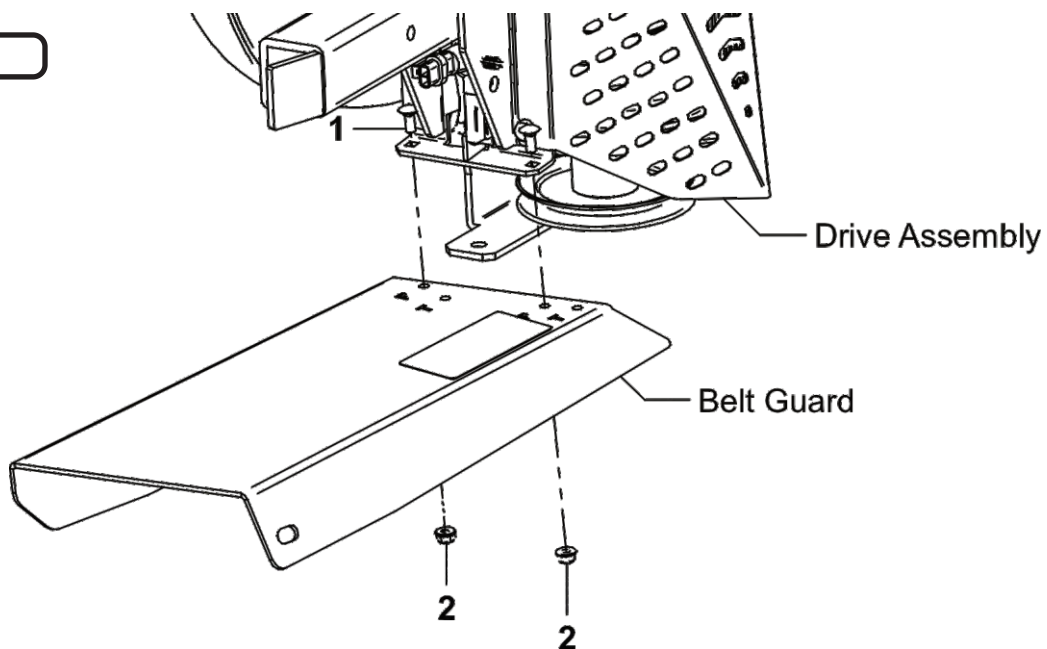

Item #	Part #	Desc.	Qty.
1	K1010	1/4"-20 x 5/8" Carriage Bolt	2
2	K2014	1/4"-20 Ny-Flange Lock Nut	2

## PTO Drive Assembly (Continued)

Attach the Idler Mount Assembly P#(A2067\_02) to the Drive Assembly using (1) 3/8"-16 x 1" HHCS (A) (Item #1), (1) 3/8"-16 x 1" Carriage Bolt (B) (Item #2) and (2) 3/8"-16 Ny-Flange Lock Nuts (Item #3). Refer to Figure B.

Leave Bolts Loose (Note: Orientation of bolts A & B.)

Next, secure the Idler Mount Assembly P#(A2067\_02) to the Belt Guard Assembly P#(A2069\_02) using (2) 3/8"-16 x 1" Carriage Bolts (Item #2) and (2) 3/8"-16 Ny-Flange Lock Nuts (Item #3). Refer to Figures C & D. Tighten All Bolts.

Figure B

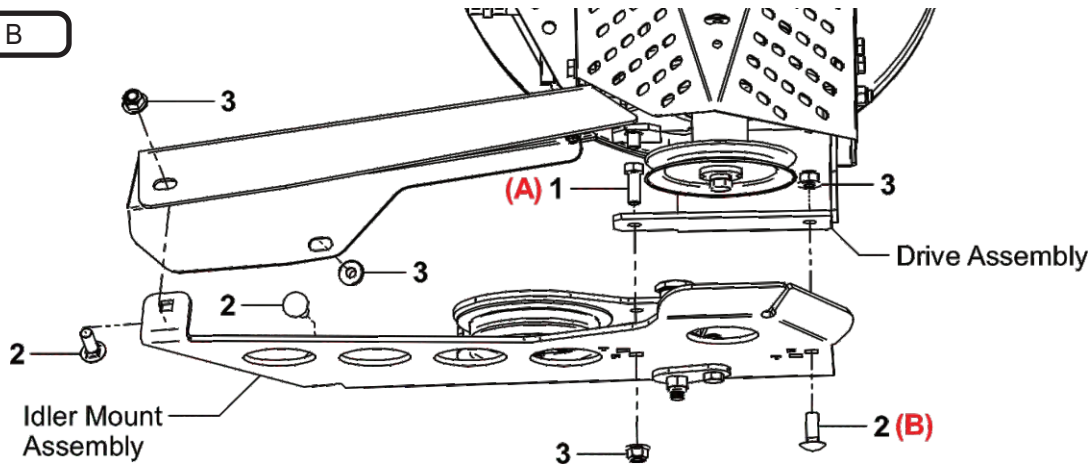

Item #	Part #	Desc.	Qty.
1	K1191	HHCS 3/8"-16 x 1" GR5	1
2	K1182	Carriage Bolt 3/8"-16 x 1"	3
3	K2038	Ny-Flange Lock Nut 3/8"-16	4

Figure C

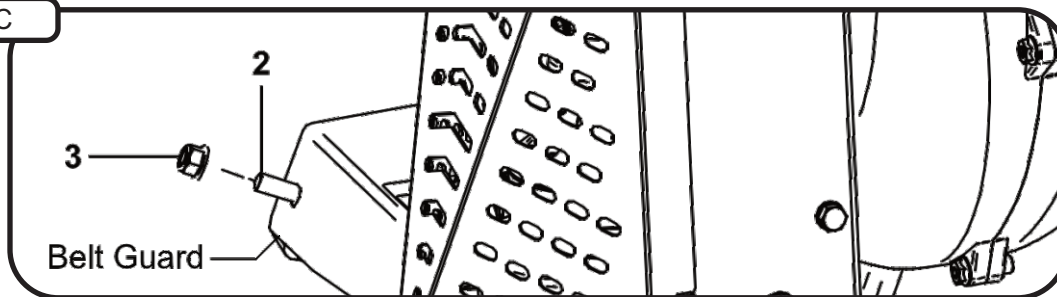
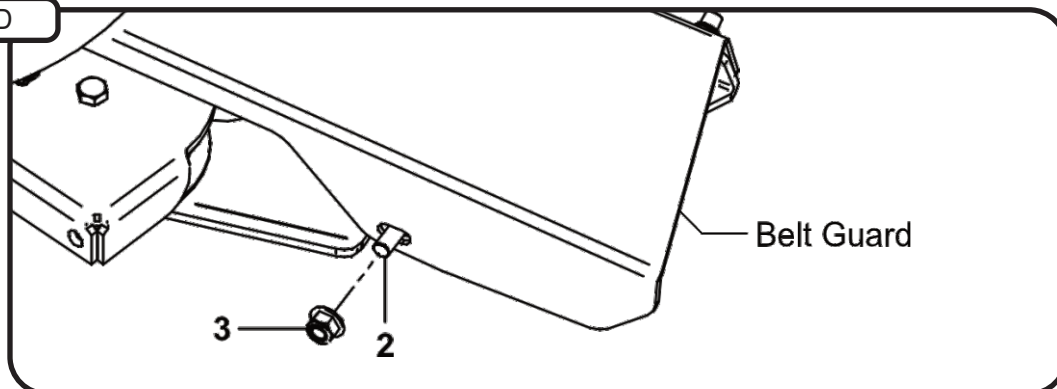

Figure D



## Drive Assembly and Belt Installation

(Note: It is recommended that someone assist during this step.)

Insert the Drive Assembly into the receiver tube on the Mount Arm Assembly until the Knob Plunger Pin engages. Once in place, turn Lock Handle clockwise until tight. Next, feed the AK83 Belt P#(M0315) between the Belt Guard and the Idler Mount Assembly. Place belt around the Engine Drive Pulley on the underside of the mower. While one person inserts a screw driver (or similar tool) into the Idler Mount Assembly and rotates lever arm clockwise, enough to relieve all tension from belt, place belt around the Drive Assembly Pulley. Once the belt is in position, carefully release the tension to tighten belt.

Refer to the images below.

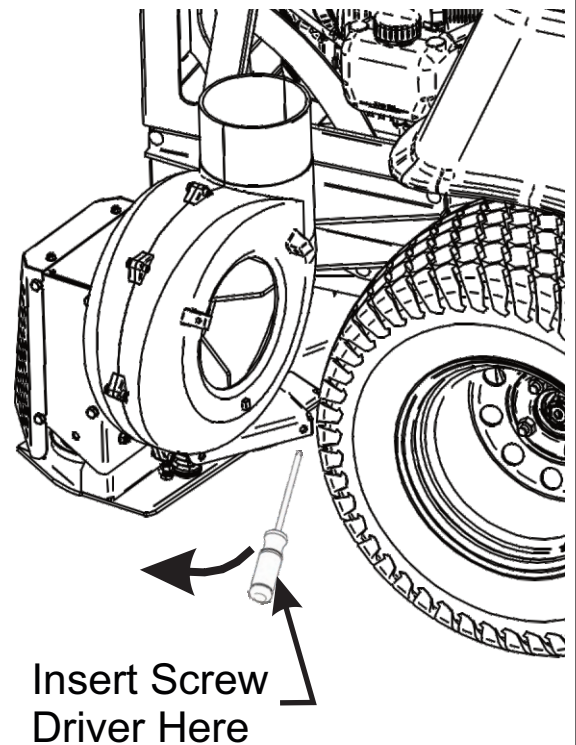
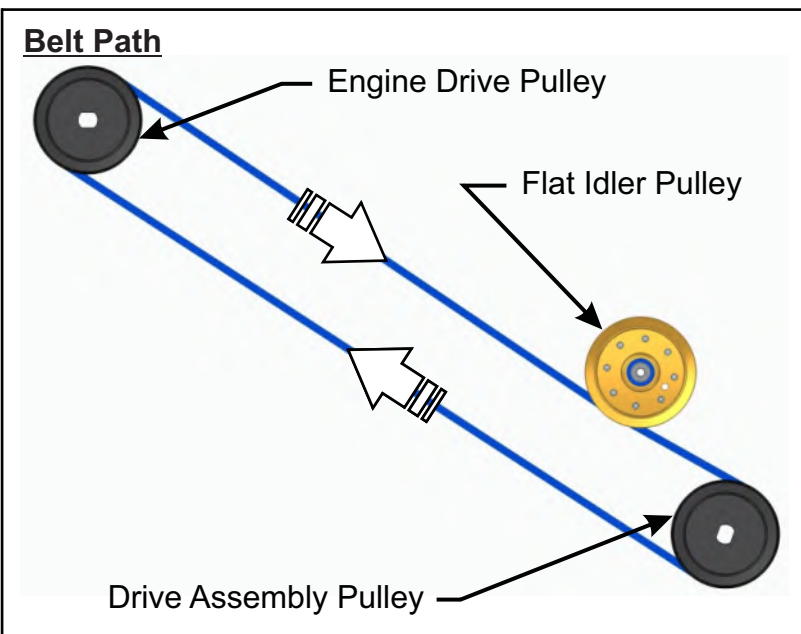
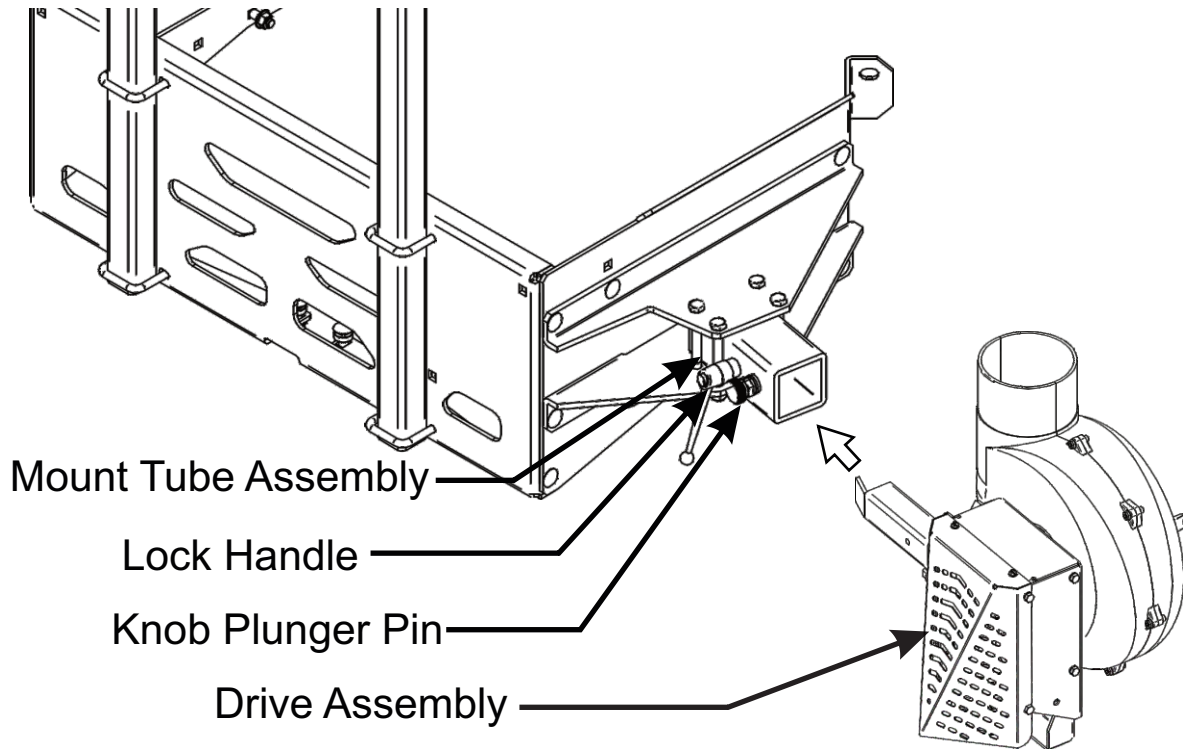

## Belt Tension Adjustment

The following information provides you a step by step guide on how to position the PTO-X Drive to obtain proper belt tension before use. Failure to set proper belt tension can result in drive damage and frequent belt replacements.

In order to properly tension your belt you will need the following tools:

- Impact Wrench
- 9/16" Socket
- 9/16" Open-End Wrench
- 7/16" Open-End Wrench
- Gates Tension Gauge (See Figure A)
- Tape Measure
- Marking Pen

Figure A

Gates Tension Gauge



**Step 1** - Remove the top belt guard from the drive assembly. See Figure B.

Figure B

Top Belt Guard

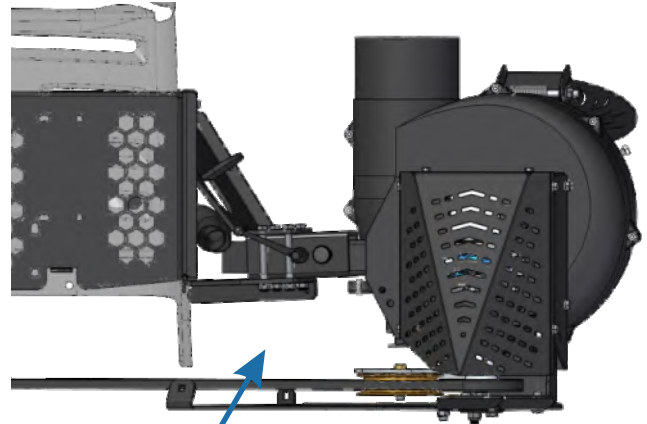

Belt Guard Removed

**Step 2** - Using a measuring tape, measure from the pulley center to approximately 16" and lightly mark a line on the belt using a marking pen. See Figure C.

Figure C

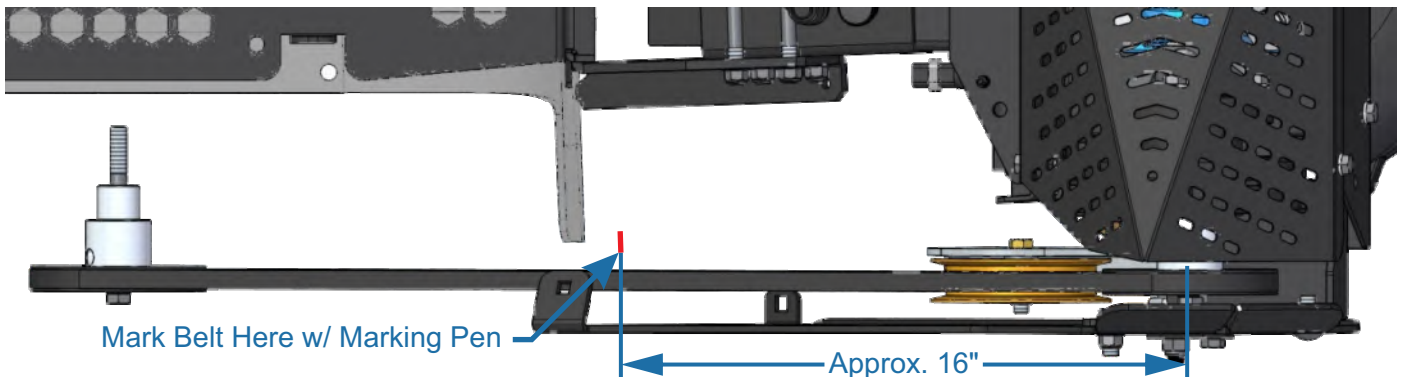



## Belt Tension Adjustment (Cont.)

**Step 3** - Place index finger into the loop on the Gates tension gauge. Position your finger over the line marked previously and keep the lower lip of the gauge below the belt. See Figure D.

Press inward until you feel a click. Remove the gauge and see the next step on how to determine the reading.

Figure D



**Step 4** - To determine the tension, position the gauge at an angle to see where the edge of the blue dial intersects with the gauge markings. In Figure E below, the gauge is reading approximately 35 lbs. of tension.

The proper belt tension should measure between 35 lbs. minimum and 40 lbs. maximum. If your reading is within this range, you can replace the top belt guard and forego the next steps.

Figure E

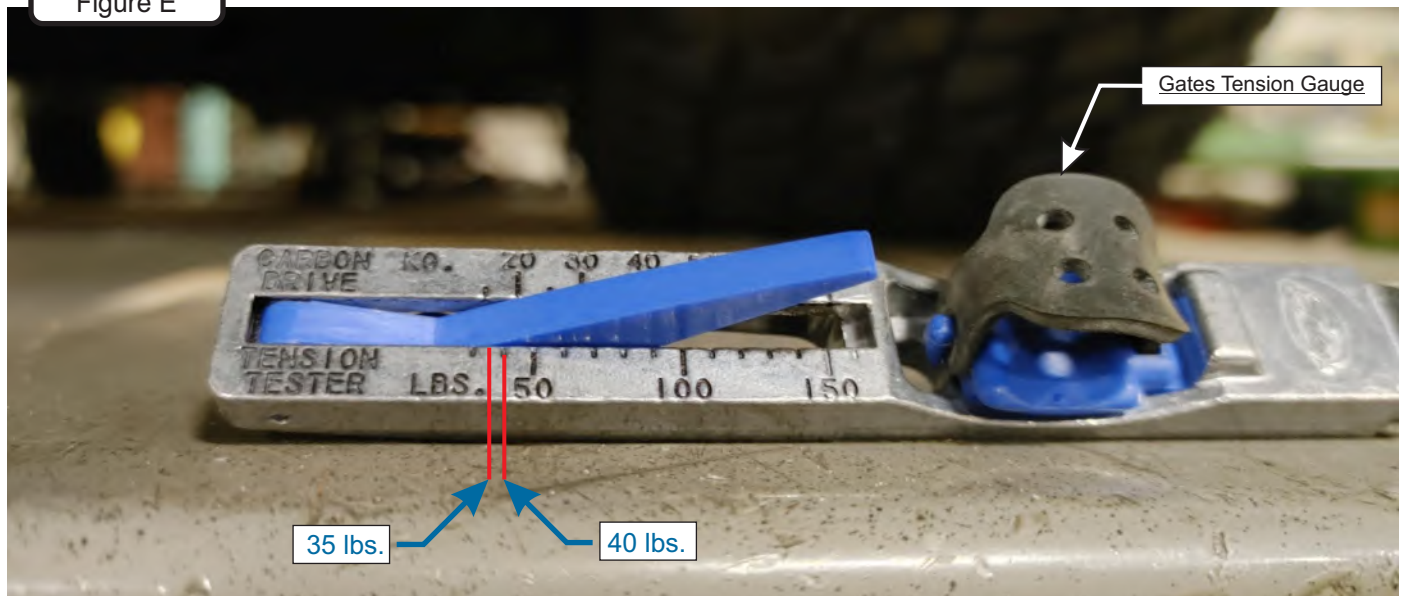

## Belt Tension Adjustment (Cont.)

Step 5 - Belt Tension Procedure To Achieve 35-40 lbs. Tension

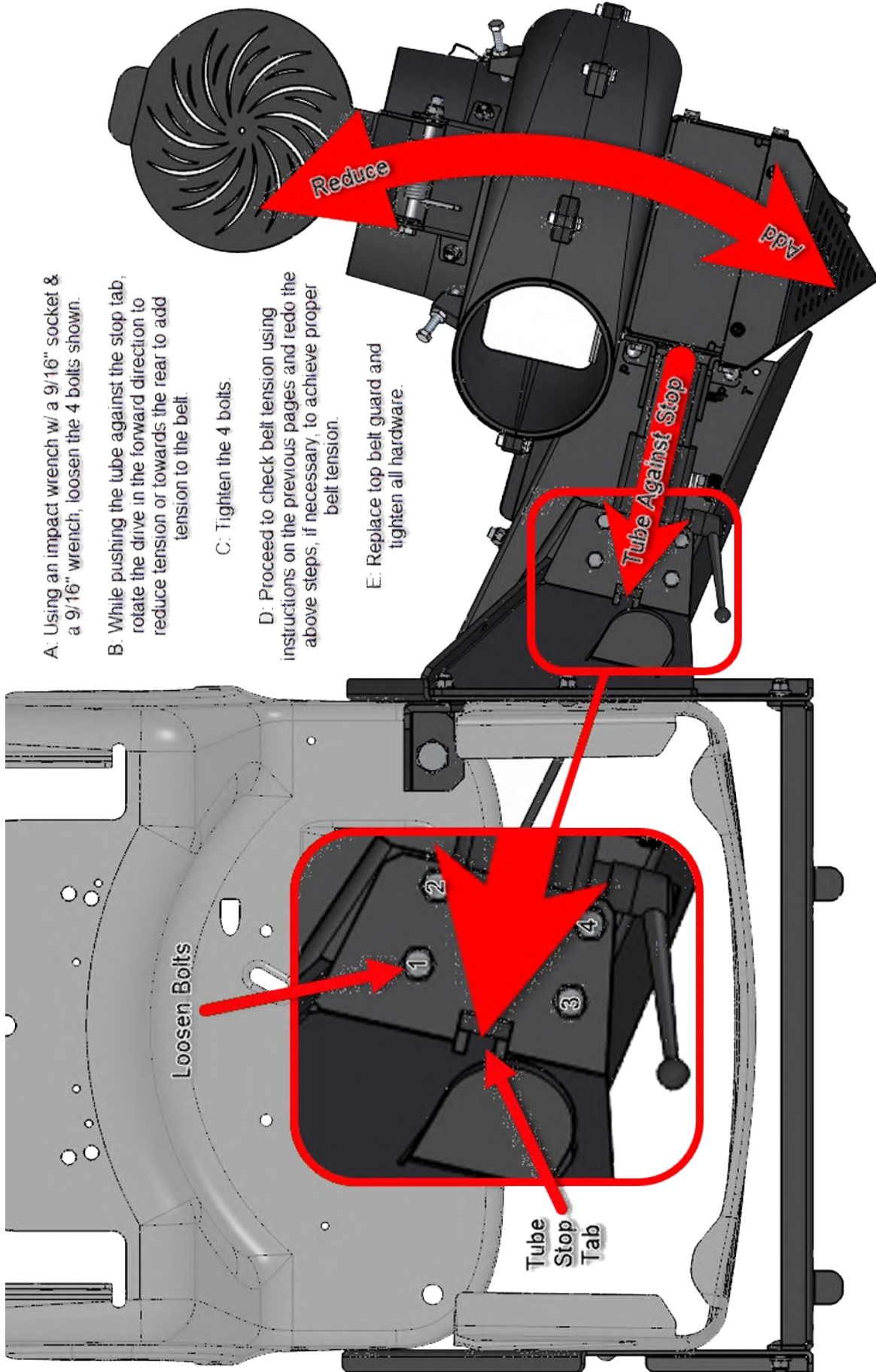

A: Using an impact wrench w/ a 9/16" socket & a 9/16" wrench, loosen the 4 bolts shown.

B: While pushing the tube against the stop tab, rotate the drive in the forward direction to reduce tension or towards the rear to add tension to the belt.

C: Tighten the 4 bolts.

D: Proceed to check belt tension using instructions on the previous pages and redo the above steps, if necessary, to achieve proper belt tension.

E: Replace top belt guard and tighten all hardware.

## Boot Kit Installation

First, remove the mower's Operator Controlled Discharge Chute (OCDC) and attach the Boot Plate Adapter (Item #7) to the far right mounting hole as shown in Figure B using (1) 3/8"-16 x 1" Hex Head Cap Screw (Item #8), (1) 3/8" Flat Washer (Item #9) and (1) 3/8"-16 Ny-Flange Lock Nuts (Item #6).

Next, secure the Boot Plate (Item #2) to the Aluminum Boot (Item #1) using (2) 3/8"-16 x 1" Carriage Bolts (Item #5) and (2) 3/8"-16 Ny-Flange Lock Nuts (Item #6). Insert the Carriage Bolts from the inside of the Boot so the threads are on the top of the Boot. This will prevent grass clippings from collecting on the threads. Leave the hardware loose until the boot plate has been attached to the mower deck.

Then, align the Boot Plate Bushings to the Boot Plate Adapter Bushings. Insert the Boot Rod (Item #3) through the Boot Plate Adapter & Boot Plate Bushings.

Finally, secure the Boot Rod using a Hair Pin Clip (Item #4). With the Carriage Bolts (Item #5) still loose, adjust the position of the boot so that there is no gap between the mower deck and the boot. Once fully adjusted and positioned, tighten all hardware at this time.

Figure A

Item #	Part #	Desc.	Qty.
1	E0033A	Boot Assembly w/ Decal	1
2	B0988	Boot Plate	1
3	B0990	Boot Plate Adapter	1
4	HB0694	HW Bag / Boot Kit / Dixie-Jacobsen	1
4.1	B0189	Boot Rod	1
4.2	K0099	Hair Pin Clip 3/32"	1
4.3	K1182	Carriage Bolt 3/8"-16 x 1"	2
4.4	K1191	HHCS 3/8"-16 x 1" GR5	1
4.5	K0047	Flat Washer 3/8" / 1.00 OD x .446 ID x .075 T	1
4.6	K2038	Ny-Flange Lock Nut 3/8"-16	3

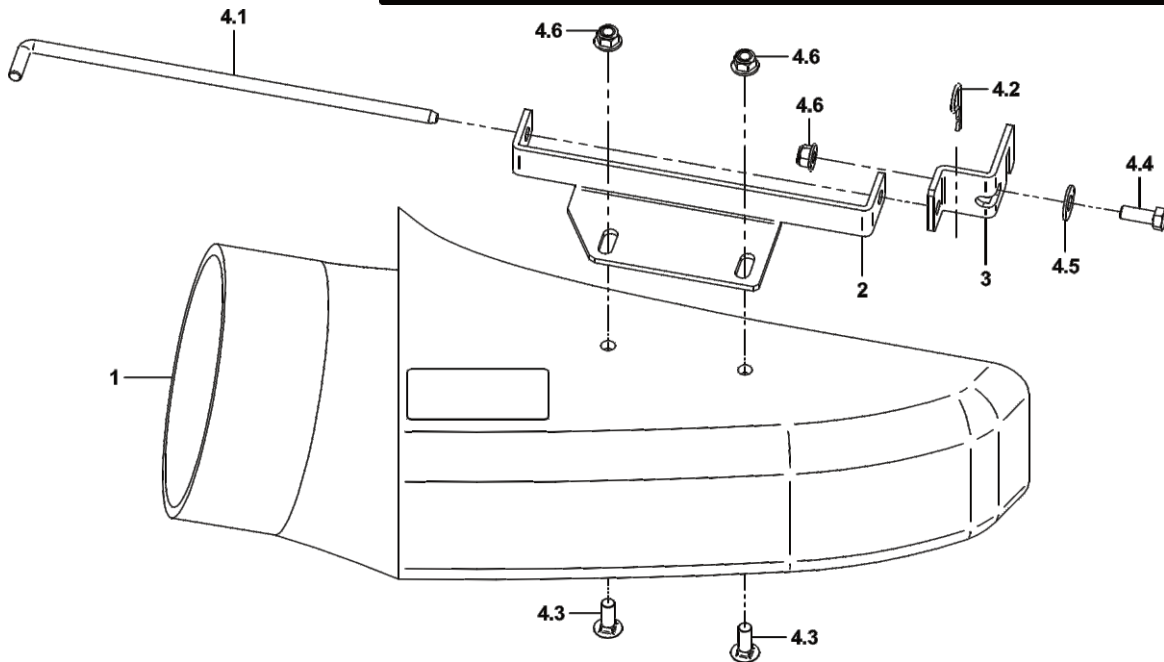

Figure B



Secure Boot Plate Adapter

## Top Assembly To Upper Frame Assembly Installation

Align the Top Assembly Pivot Holes to the Upper Frame Assembly. See Figure A below. Before fastening, pull Rubber Dust Guard outward to seal against Upper Frame Assembly (towards the mower's operator seat). Fasten the Top Assembly to the Upper Frame Assembly using (2) 5/16"-18 x 2-1/2" HHCS P#(K0125) and (2) 5/16"-18 Ny-Flange Locknuts P#(K2516). Leave the Ny-Flange Locknuts slightly loose to allow the Top Assembly to open and close easily.

Figure A

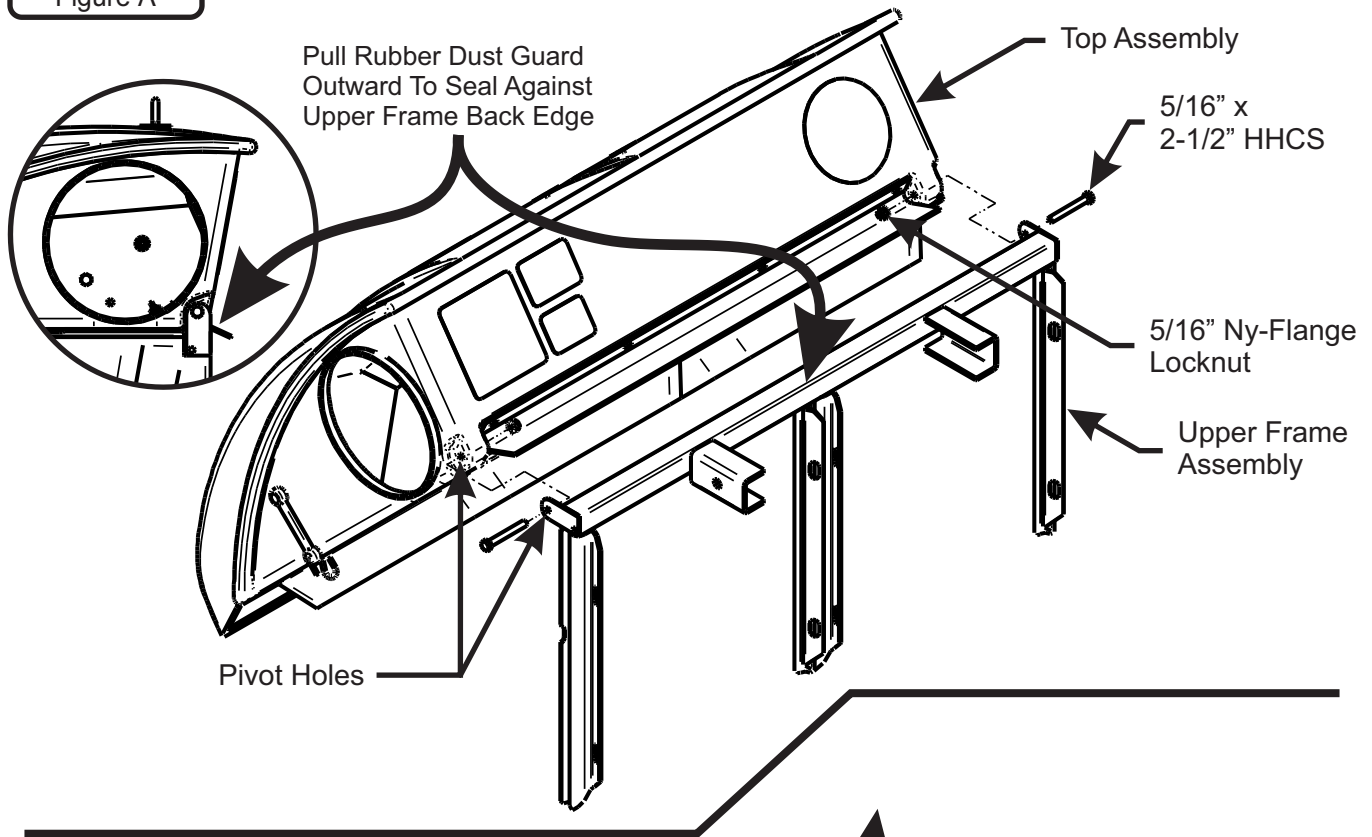

## Inlet Installation

Position the Top Assembly on its side with the Inlet Hole facing up. See Figure B. 1: Insert the Inlet from inside the Top Assembly, up through the Inlet Hole, until the Inlet Retaining Lip meets the Inlet Hole. 2: Position the Inlet as shown in Figure B, then pull the Inlet until a portion of the Inlet Retaining Lip protrudes from the Inlet hole. 3: Next, lift the Inlet as shown in Figure B until all of the Inlet Retaining Lip protrudes from the Inlet Hole. Once installed, the Inlet should pivot freely about the Inlet Hole.

Figure B

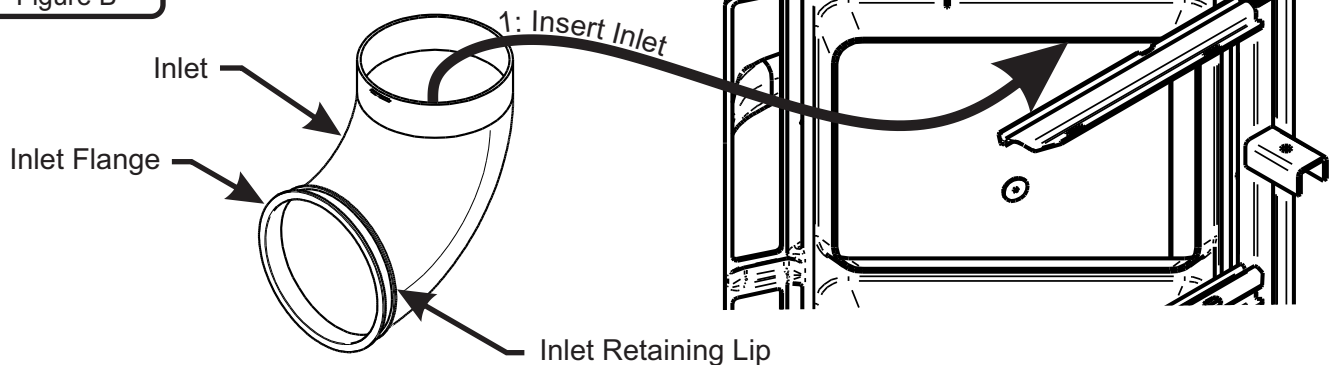

## Hinge Kit Assembly Installation

Assemble the Hinge Kit using (1) Latch Plate P#(B0884), (1) 5/16"-18 x 1-1/4" HHCS P#(K1156), (1) 5/16"-18 Ny-Flange Lock Nut P#(K2516), (3) 5/16" Flat Washers P#(K0042), (1) Latch Spacer P#(S0006), (2) Extra Heavy 5/16" Fender Washers P#(K0505) and (1) 5/16"-18 Lock Nut P#(K0506). Leave the nuts loose enough to allow fluid movement of the top when opening and closing. When opened, the top should rest in the Latch Plate Slot.

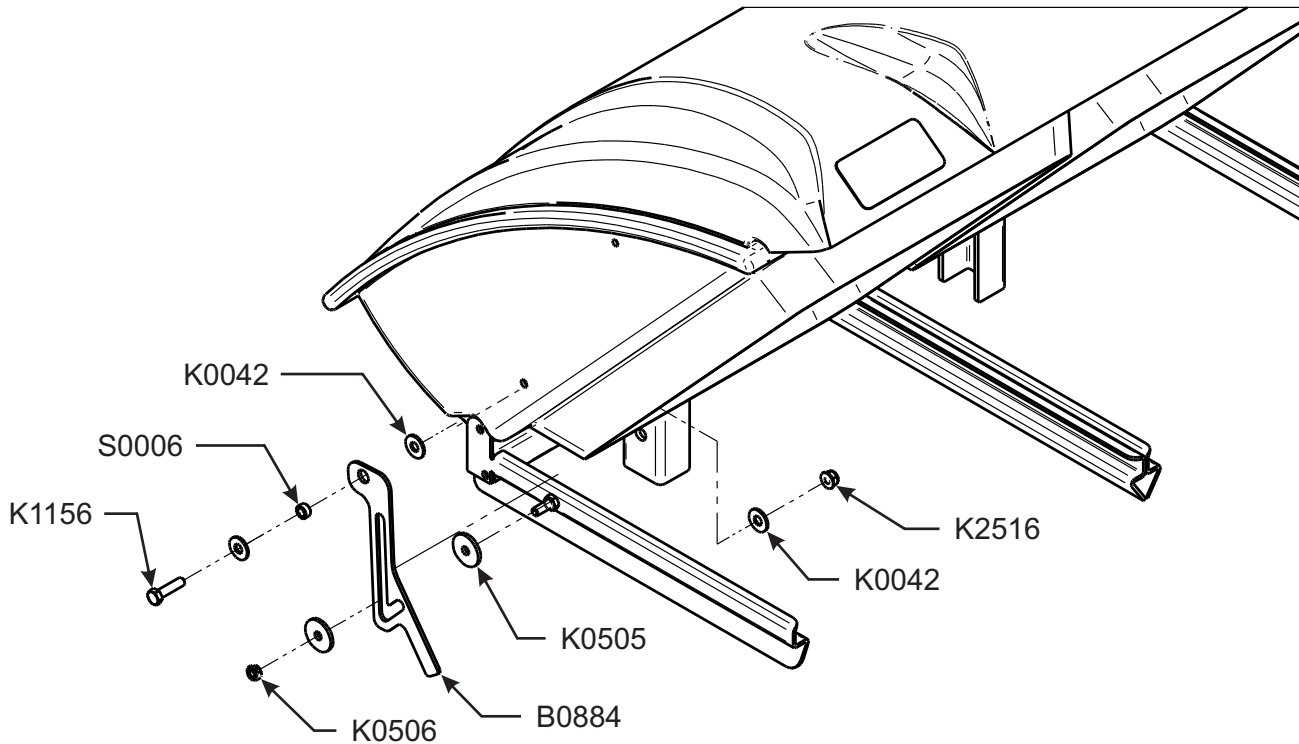

## Even Bag Fill Adjustment

Flap can be adjusted Up/Down depending on mowing conditions. Adjust flap up to allow more dense material to reach left bag. Adjust flap down to allow less dense material to reach the right bag. Once adjusted properly, both bags should fill evenly, but may require further adjusting when mowing conditions change.

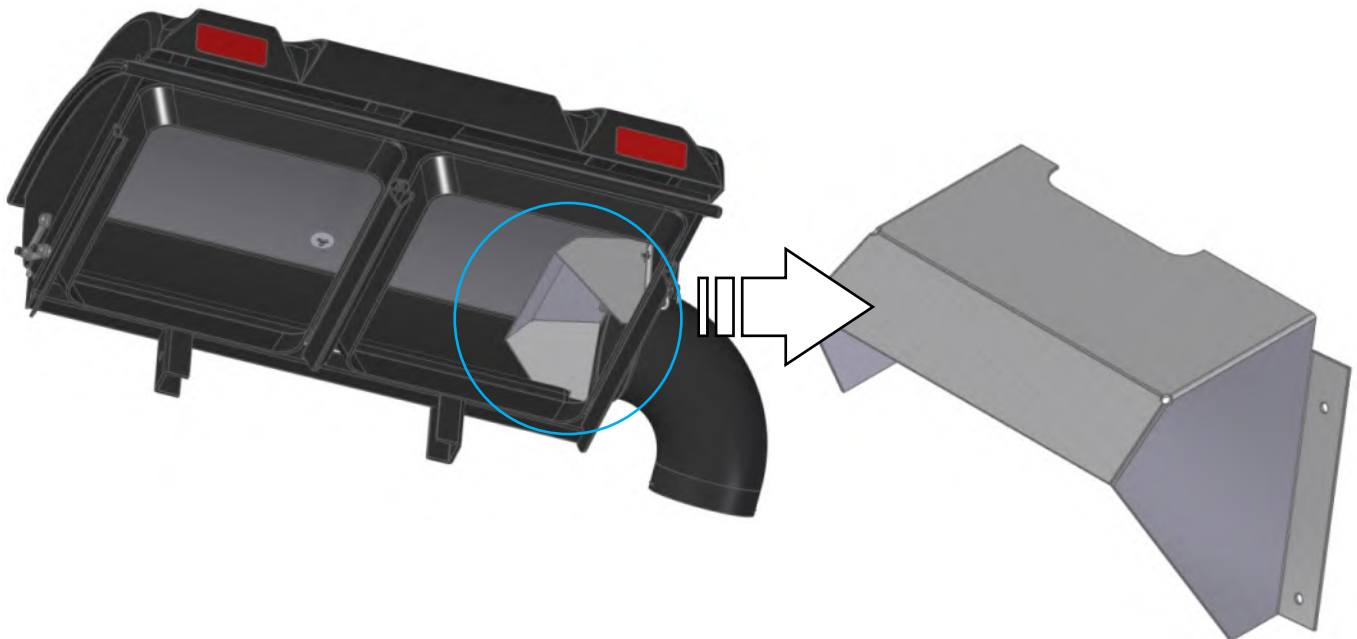

## Bag Assembly

First, take one of the Bag Ring Split Ends and insert it through the Bag Seam Opening. Next, rotate the Bag around the Bag Ring (1) full turn (360 degrees) until the Bag Ring Split Ends and the Bag Seam Opening are positioned on the same side. Then, connect the Bag Ring Split Ends using (1) End Connector. Last, rotate the Bag Ring and the End Connector Assembly (1/2") turn (180 degrees) to position the Connector opposite of the Bag Seam Opening. Note Final End Connector Location below in Figure A. Repeat for each Bag.

Figure A

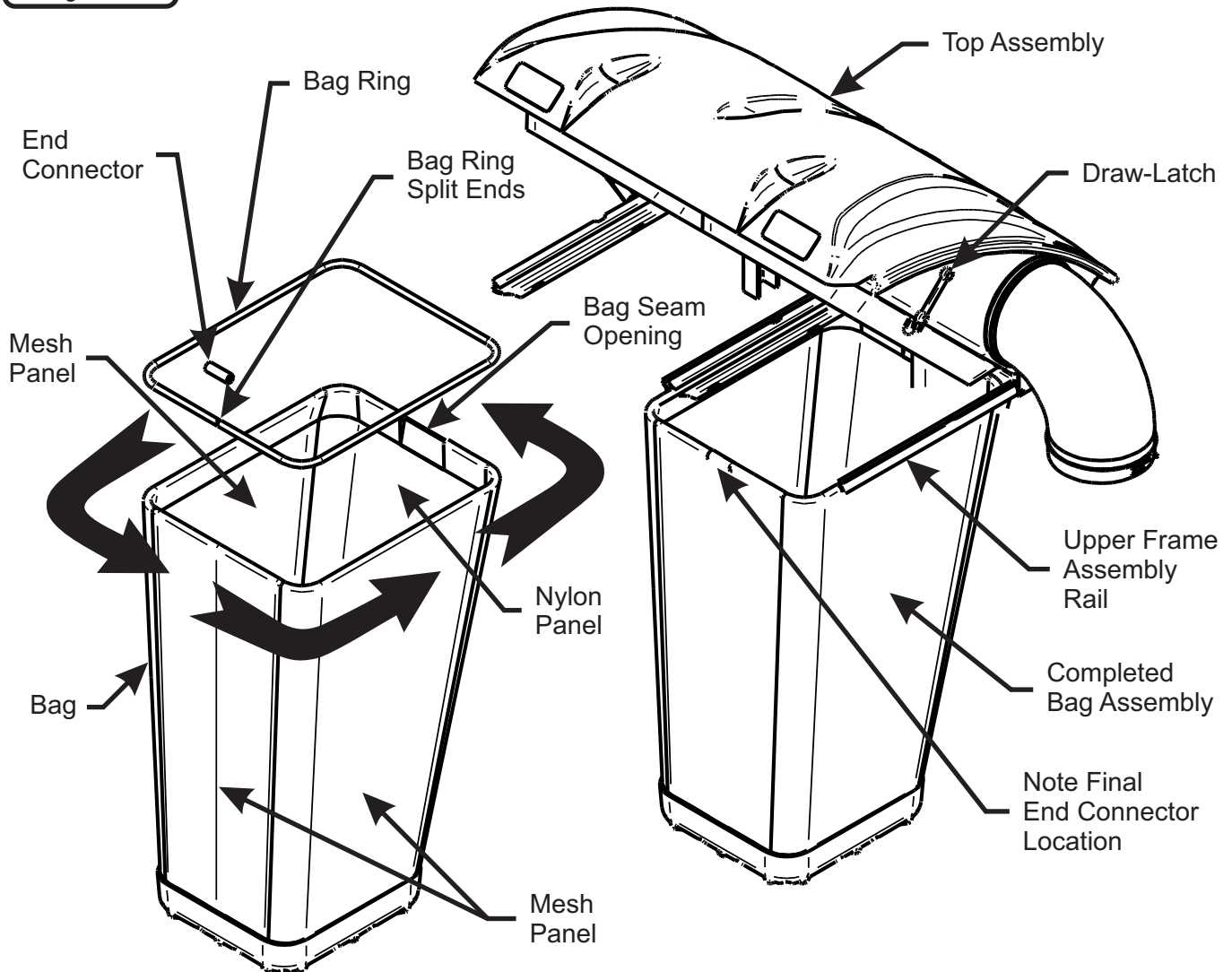

## Bag Assembly Installation

Slide the Completed Bag Assembly into the Upper Frame Assembly Rails and close the Top Assembly. Fasten the Draw-Latch on either side to hold the bagger closed.

## Wiring Harness Installation



### WARNING

**To Prevent Serious Injury-  
Proper Installation Of Safety Interlock Harness  
Is Mandatory. Please Check That All Interlock  
Points Work Correctly Once Installed.**

Route the 2 Way Metri-Pack Connector (P#P0280) around the right side of the engine and down between the side of the ROPS to the right of the Right Mount Plate connecting the Quick Connect Plug (#1) located on the PTO Drive. Refer to Figure A.

Attach the Positive Lead from the Wiring Harness (P#A2144) connected to the Metri-Pack 2 Way Connector (P#P0280) to the PTO Switch (P#J2001) by connecting the Female Disconnecter (P# P0106) from the Positive Lead to the Switch Terminal (A) on the Switch. Refer to Figure B on the next page.

Insert the PTO Switch in and through the PTO Switch Bracket (P#B1020) then attach and secure the Safety Cover (P#P0073).

Before routing the PTO Switch (#2), locate and loosen the existing cap head screw located on the bottom right side of the mower's control panel. Attach the PTO Switch Bracket by sliding it behind the cap head screw and tightening the screw. Refer to Figure A. (Note: This is the recommended positioning of the PTO Switch, the PTO Switch could be mounted anywhere within reasonable distance and clearance to the right of the operator's seat)

Route the PTO Switch to the positive terminal of the battery (#3) using the Ring Terminal (P#P0086) of the Positive Lead to secure the attachment. Route the Negative Lead to the engine block (#4) using the Ring Terminal of the Negative Lead to secure the attachment. Refer to Figure A.

Use the zip ties (P#J0245) that are provided to secure the wires in place.

Figure A

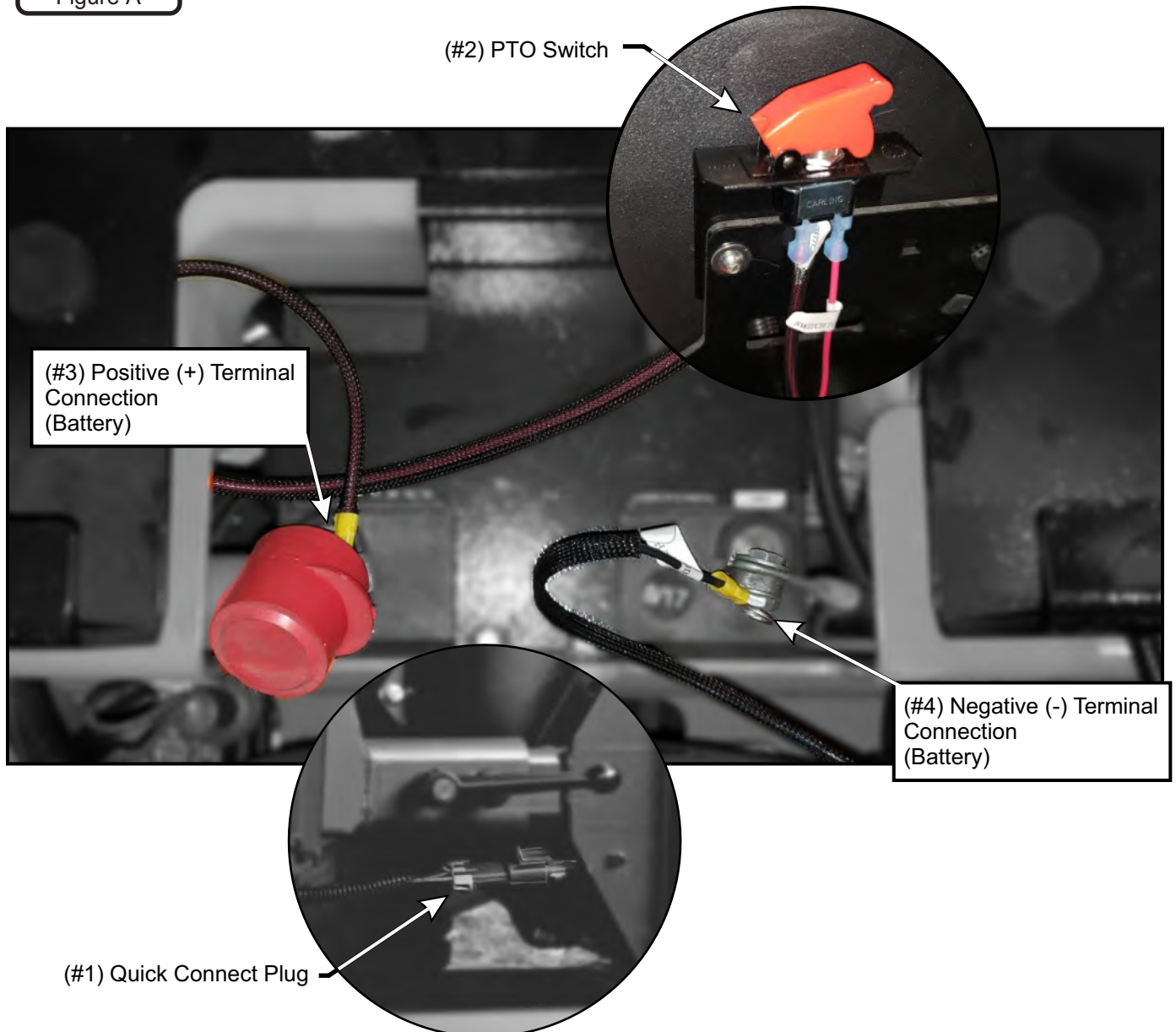

# Wire Harness Installation (Continued)

Figure B

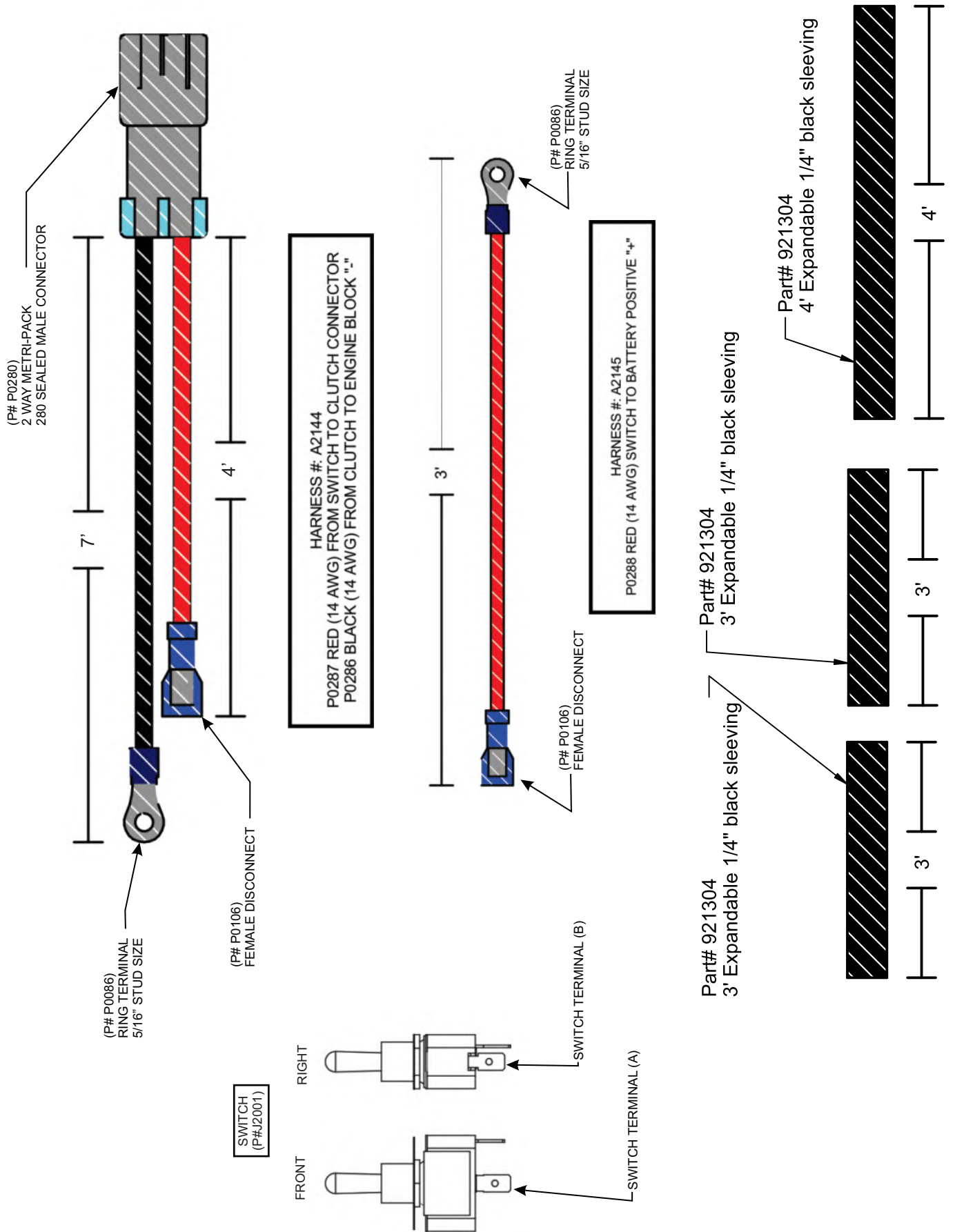



## Length Of Hose Adjustment

The hoses in the following steps must be cut to fit your machine. Do not cut the hoses until you have tried to fit them on your machine. Remember that the hoses need to be long enough to allow for the opening and closing of the collection system as well as allowing ample clamping surface between each component.

## Upper Hose Installation

Slide a Hose Clamp P#(J0060) over one end of the 6" Upper Hose. Secure this end of the 6" Upper Hose to the Blower Outlet. See Figure below for details. Secure opposite end of the 6" Upper Hose to the Inlet with another Hose Clamp P#(J0060). Make sure both ends are securely fastened by tightening the Hose Clamp.

## Lower Hose To Blower Cone Installation

Slide a Hose Clamp P#(J0080) over both ends of the Lower Hose. Secure one end of the Lower Hose to the Blower Cone and fasten by tightening the Hose Clamp.

## Lower Hose To Boot Installation

Take the unattached end of the Lower Hose and secure it to the circular end of the Boot and fasten by tightening the Hose Clamp.

Tip: Before securing Hose Clamp fully, rotate Lower Hose counter-clockwise (away from yourself) approximately 1" to aid in retaining Boot to mower deck.

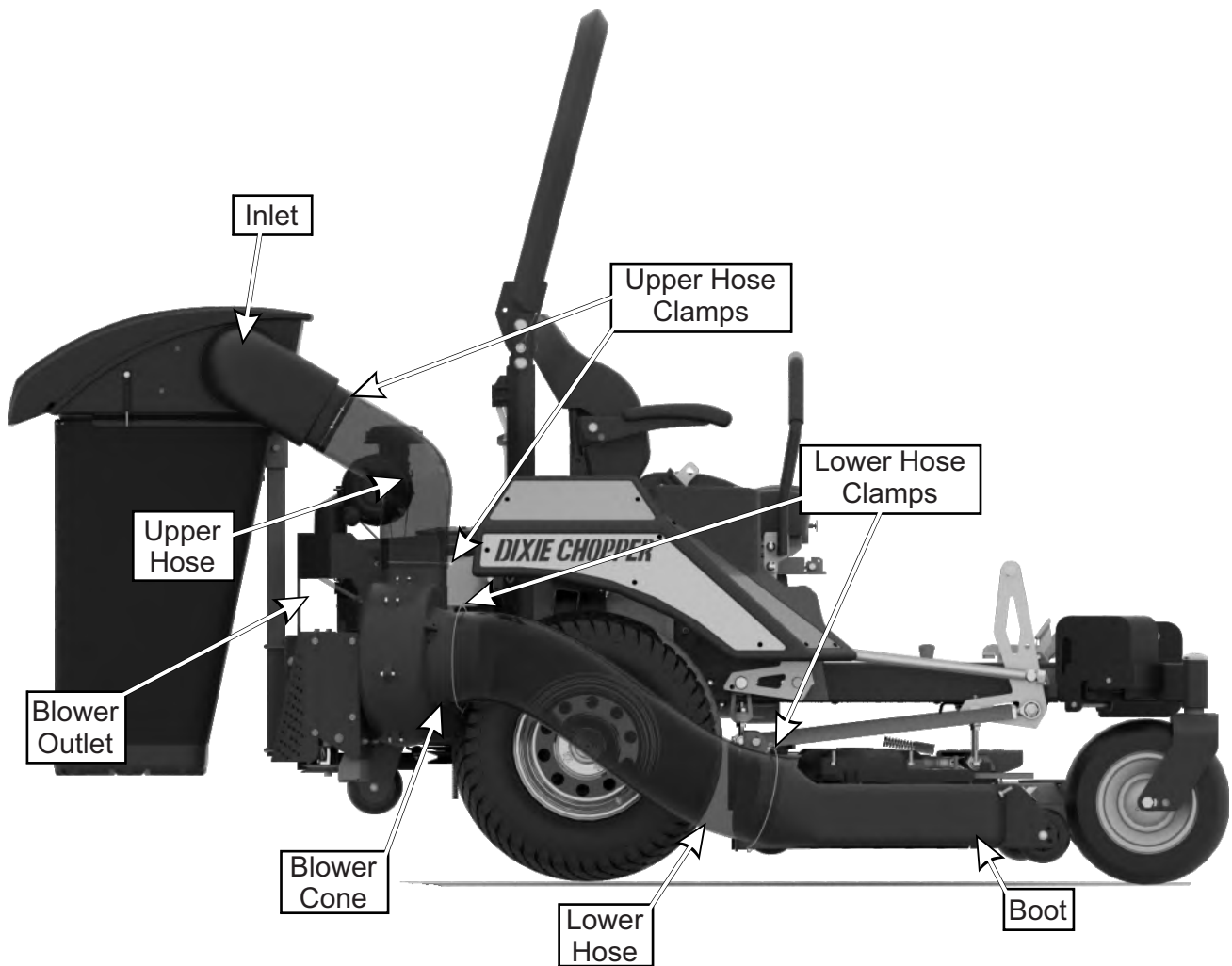

## Impeller Blade Removal/Replacement

**To Remove:** First remove the 5/16"-24 x 1" HHCS P#(K0428) (#1), Taper Lock Bushing Washer P#(K0284) (#3), (2) 5/16 Flat Wahers P#(K0042) and Spacer Bushing P#(S0159) (#4) from the Taper-Lock Bushing P#(S0157) (#5). Next remove the (2) 1/4"-20 x 1" HHCS (#2) and place them into the threaded holes of the Taper-Lock Bushing (#5). Gradually thread each bolt evenly into the Taper-Lock Bushing, forcing the blade to break-away from the Taper-Lock Bushing. If the Impeller will not move, carefully hit the base of the Impeller, between each vein, with a hammer, then try again.

**To Replace:** Place Impeller Blade over the engine shaft. Slide the Taper-Lock Bushing (#5) on to the engine shaft and into the Impeller Blade, aligning the **non-threaded** holes of the Taper-Lock Bushing to the threaded holes of the Impeller Blade. Fasten by using (2) 1/4"-20 x 1" HHCS (#2), (1) Spacer Bushing (#4) (1) Taper-Lock Bushing Washer (#3), and (1) 5/16"-24 x 1" HHCS (#1). Torque to the proper specifications in the torque chart on the back of this manual. Next, rotate the Impeller Blade to ensure that the blade is clear of contact on all sides of the blower housing.

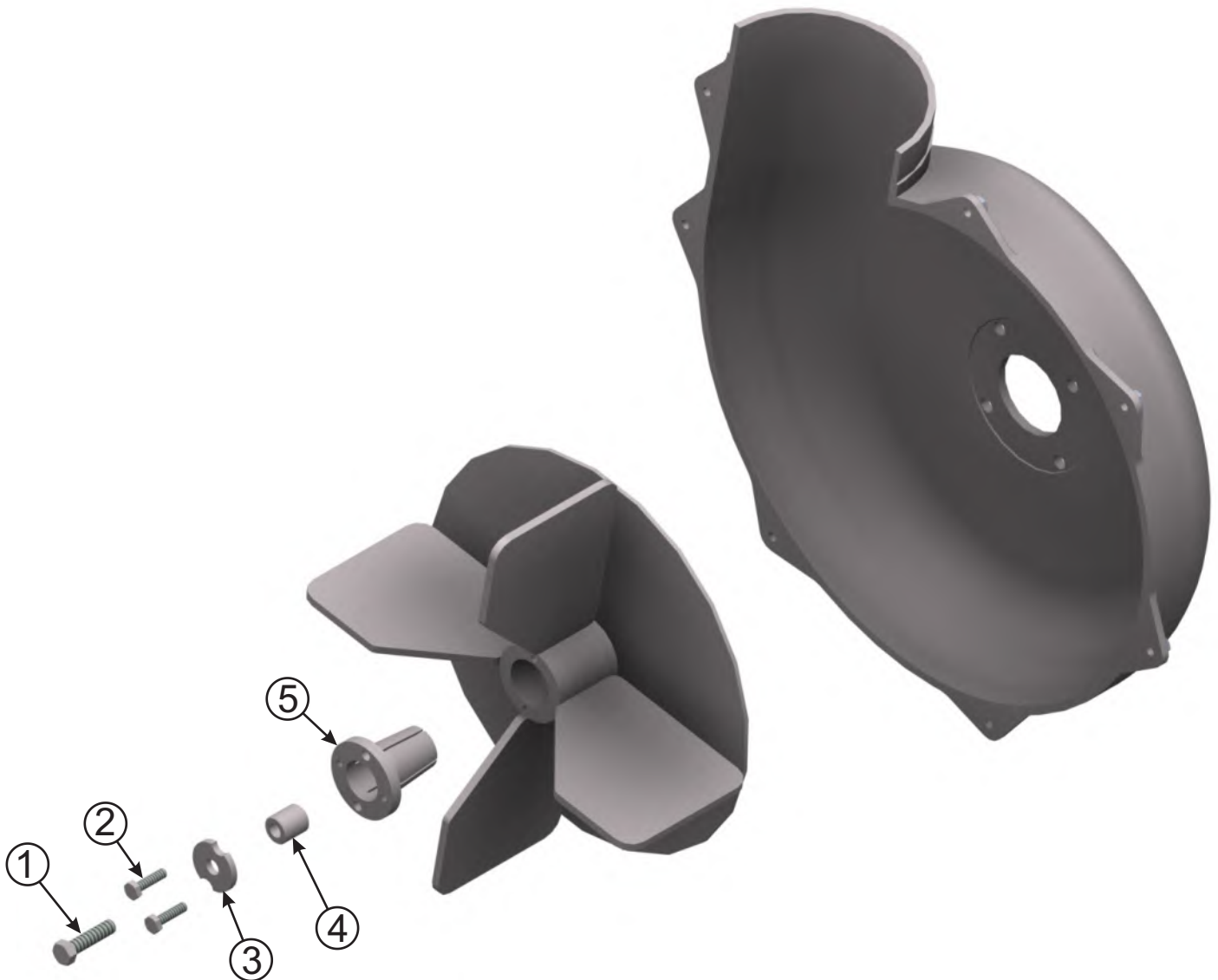

## Weight Kit Installation

### Quad Weight Kit

Go to page 27 for the installation instructions of the (4) Suitcase Weights P#(Y0025).

First, remove the existing front name plate by removing the top (2) set of hardware and bottom (2) set of hardware. Refer to Figure A (Dixie Chopper Unit shown).

Figure A

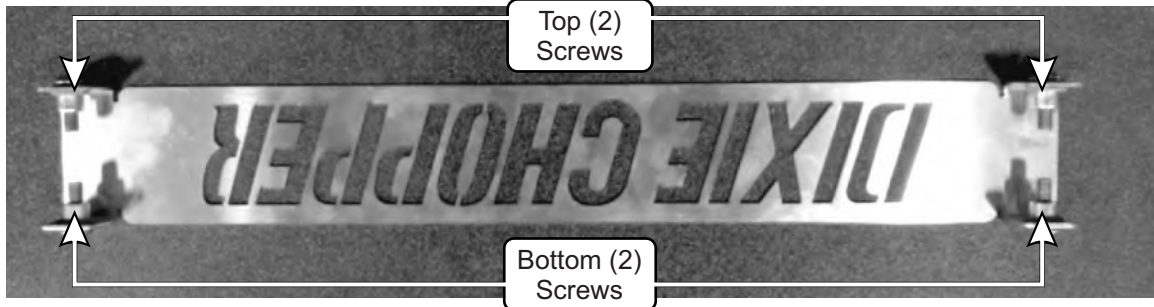

Next, remove the footrest to expose (4) large carriage bolts and nuts, located behind the name plate. Remove and keep (2) existing nuts from the existing carriage bolts, (1) from the far left and (1) from the far right. Refer to Figure B.

With the nuts removed, place the Quad Weight Bracket P#(B2602) over the front of the mower, under the footrest and over the exposed bolts as shown in Figure B. Secure the Quad Weight Bracket by reusing the (2) nuts removed earlier to the existing carriage bolts. Refer to Figure C for the installed Quad Weight Bracket.

Note: Some part and part features have been hidden from view for visual clarity.

Figure B

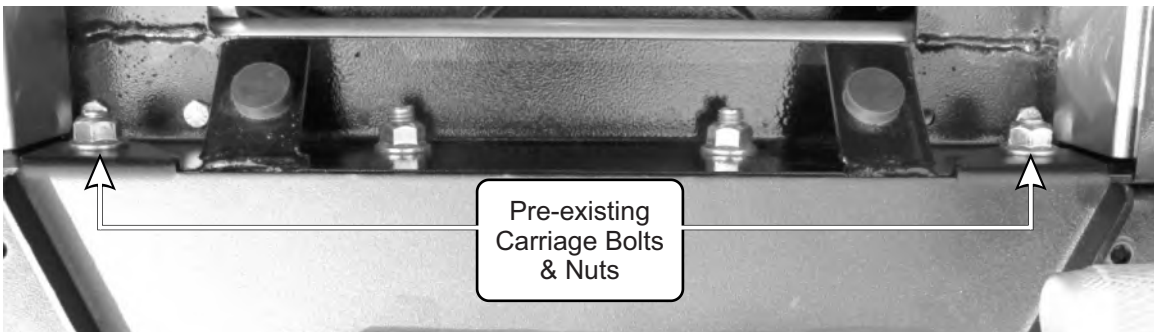
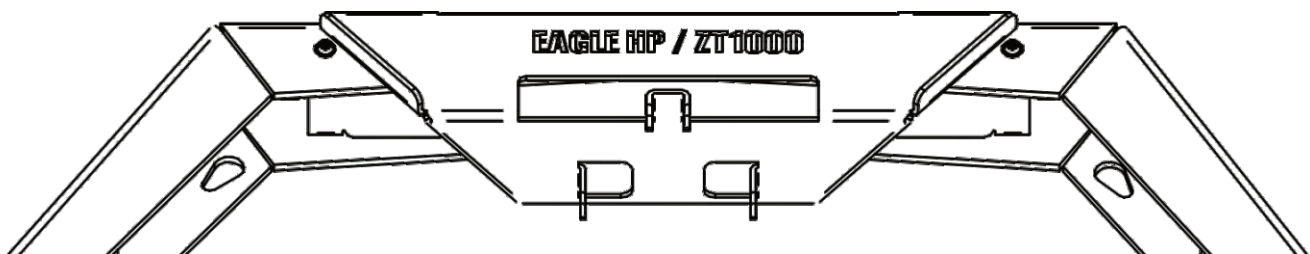

Figure C



## Weight Kit Installation (Continued)

### Dual Weight Kit - Left Caster

Go to page 27 for the installation instructions of the (2) Suitcase Weights P#(Y0025).

First, Install the Caster Weight / Support Bracket (Item #2) onto the Dual Weight / Caster Bracket (Item #1) by using (2) 3/8-16" x 1" Carriage Bolts (Item #5.1) and (2) 3/8-16" Ny-Flange Lock Nuts (Item #5.3). Refer to Figure D.

Next, position and align the Caster Weight / Brace (Item #3) and the installed Support Bracket (Item #2) on to the mower's caster as shown in Figure D. Place the Caster Brace on the inside of the Caster and the Support Bracket on the outside of the Caster. Secure the Caster Brace onto the Support Bracket by using (2) 3/8-16" x 1-1/4" Carriage Bolts (Item #5.2) and (2) 3/8-16" Ny-Flange Lock Nuts (Item #5.3). Leave hardware loose enough to be adjusted.

Figure D

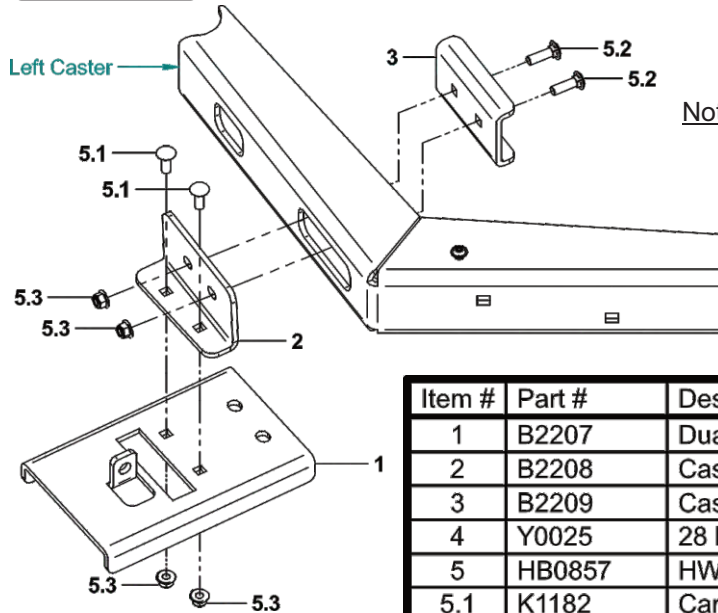

**Note:** Position the bolt holes with the through holes of the Caster.

Leave hardware relatively loose on this step.

Item #	Part #	Desc.	Qty.
1	B2207	Dual Weight / Caster Bracket / Eagle HP	1
2	B2208	Caster Weight / Support Bracket	1
3	B2209	Caster Weight / Brace	1
4	Y0025	28 lb. Suitcase Weight	2
5	HB0857	HW Bag / Dual Weight Kit / Eagle HP	1
5.1	K1182	Carriage Bolt 3/8"-16 x 1"	2
5.2	K1183	Carriage Bolt 3/8"-16 x 1-1/4"	2
5.3	K2038	Ny-Flange Lock Nut 3/8"-16	4
5.4	K0342	1/2"-13 x 1-1/4" HHCS	1
5.5	K1521	1/2" Flat Heavy Washer	1
5.6	K1247	1/2"-13 Nyloc Nut	1
5.7	A0312	Hitch Pin Weldment	1
5.8	K1478	Hair Pin Cotter / Double Loop	1

Figure E

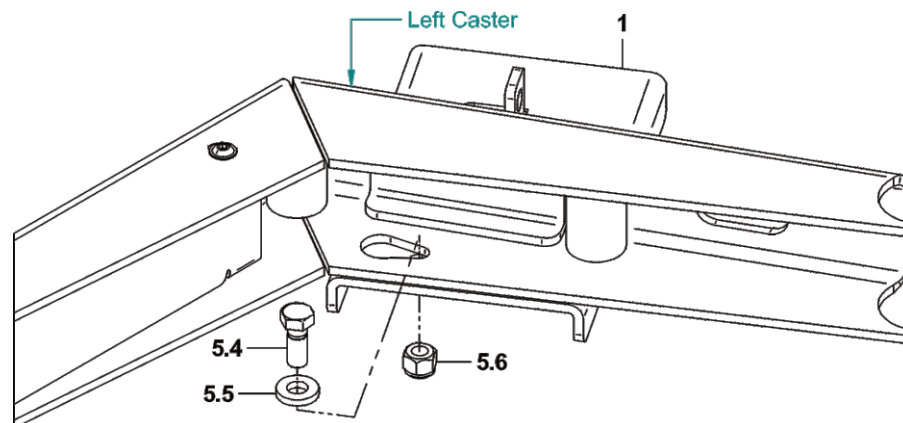

Then, position and align the Dual Weight / Caster Bracket's (Item #1) rear bolt hole to the hole on the inside of the mower's Caster. Refer to Figure E above. Once aligned, secure the Dual Weight / Caster Bracket by using (1) 1/2"-13 x 1-1/4" HHCS (Item #5.4), (1) 1/2" Flat Heavy Washer (Item #5.5) and (1) 1/2"-13 Nyloc Nut (Item #5.6).

Tighten all hardware at this time.

# Weight Kit Installation (Continued)

## Suitcase Weight Installation

Insert (2) Suitcase Weights (Item #2) on to the Weight Bracket (Item #1) & align the mount hole of the Weights w/ the hole on the Weight Bracket tab. Fasten the Weight to the Weight Bracket using (1) Hitch Pin (Item #3.1) and (1) Hair Pin Cotter (Item #3.2).

See Figure F for the Quad Weight Kit and Figure G for the Dual Weight Kit.

Figure F

Item #	Part #	Desc.	Qty.
1	B2602	Quad Weight Bracket / Eagle HP	1
2	Y0025	28 lb. Suitcase Weight	4
3	HB0695	HW Bag / Weight Kit / Dixie Jacobsen	1
3.1	A0312	Hitch Pin Weldment	2
3.2	K1478	Hair Pin Cotter / Double Loop	2

Quad Weight Kit

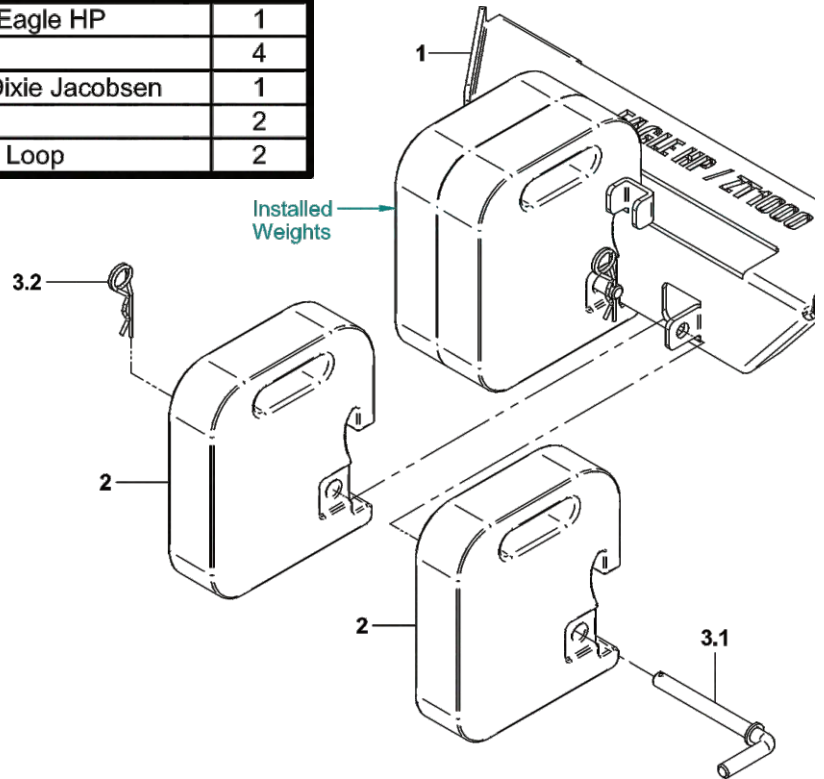
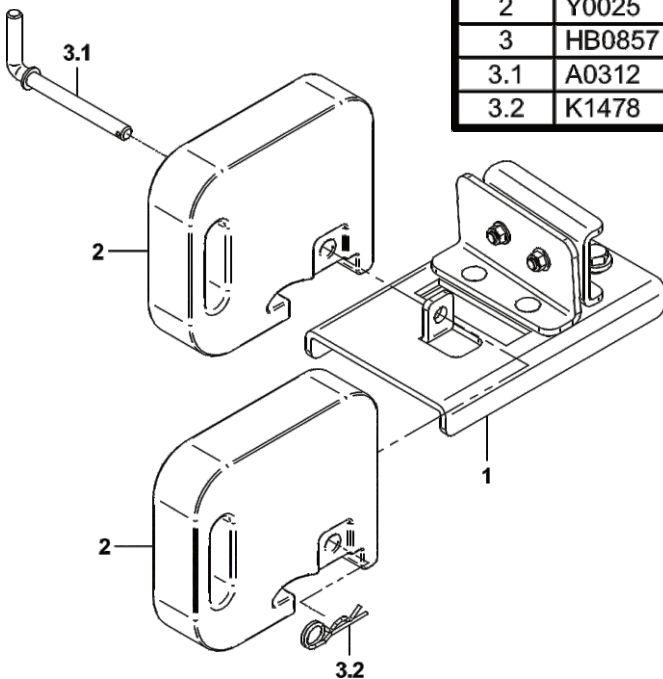

Figure G

Item #	Part #	Desc.	Qty.
1	B2207	Dual Weight / Caster Bracket / Eagle HP	1
2	Y0025	28 lb. Suitcase Weight	2
3	HB0857	HW Bag / Dual Weight Kit / Eagle HP	1
3.1	A0312	Hitch Pin Weldment	1
3.2	K1478	Hair Pin Cotter / Double Loop	1

Dual Weight Kit



## A2207 Mount Arm / Tube Assembly Exploded Parts View

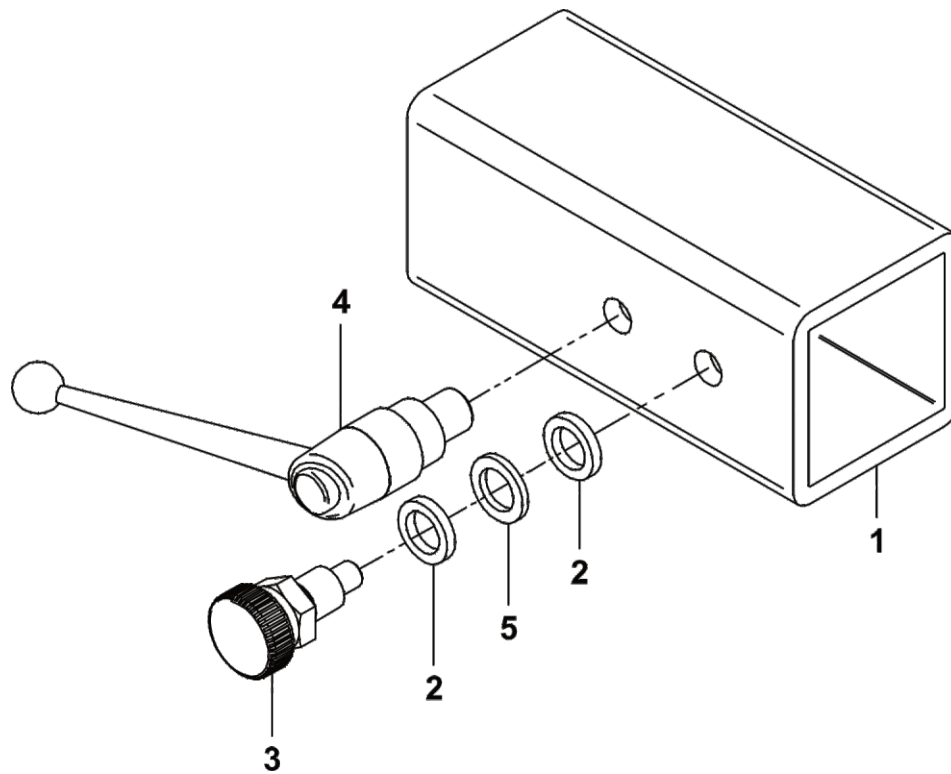

Item #	Part #	Desc.	Qty.
1	B0931	Tube / Mount Arm	1
2	J0013	Nylon Flat Washer 1/2" x .750" OD Grade 6/6	2
3	J0020	Knob Plunger Pin 1/2"-13	1
4	J0009	Adjustable Handle 1/2"-13 x .59 Male	1
5	K0027	Flat Washer 1/2" / .787 OD x .512 ID x .090 T	1

## A2092 Idler Arm Assembly

Item #	Part #	Desc.	Qty.
1	A2070_01	Idler Arm Weldment	1
2	K1467	Flat Washer M6 x 12mm OD	1
3	J0801	1/4"-28 Zirc Fitting	1

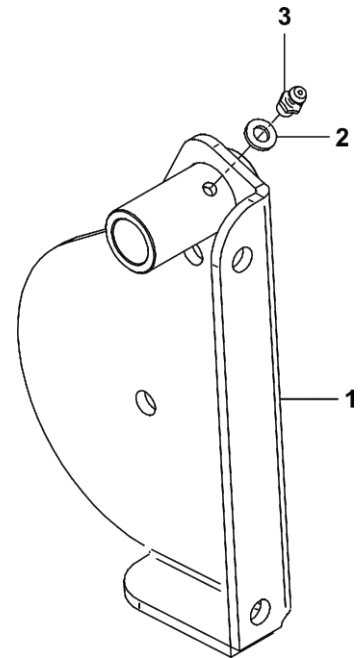

## A2067 02 Idler Mount Assembly

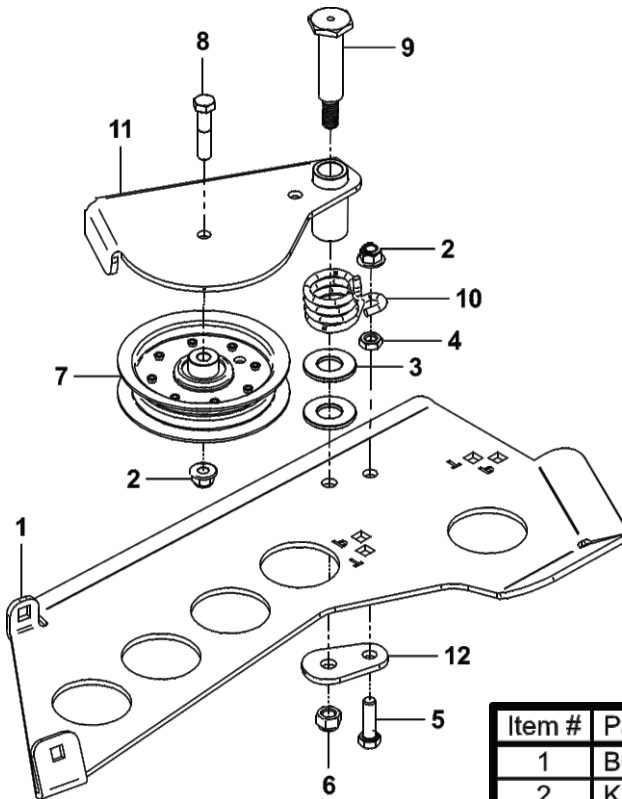

Item #	Part #	Desc.	Qty.
1	B0958_02	Idler Mnt Pl	1
2	K2038	Ny-Flange Lock Nut 3/8"-16	2
3	K1463	Flat Washer .720 ID x 1.500 OD x .250 T	2
4	K1219	Jam Nut 3/8"-16	1
5	K1192	HHCS 3/8"-16 x 1-1/4" GR5	1
6	K0329	Nylock Nut 7/16"-14 GR8	1
7	M0003	Idler Pulley	1
8	K1462	HHCS 3/8"-16 x 1-3/4" GR8	1
9	K1464	Shoulder Bolt 7/16"-14 / Idler	1
10	J0024	Torsion Spring	1
11	A2092	Idler Arm Assy.	1
12	B0974	Idler Base Plate	1

# A2058 01 Gearbox Sub-Assembly Exploded Parts View

Item #	Part #	Desc.	Qty.
1	A2048	Clutch Flange	1
2	M0002	Gearbox	1
3	N0005	7/8" Pillow Block Bearing / Fenner	1
4	J0272	Woodruff Key #9	1
5	K0035	Set Screw 5/16"-18 x 1/4" Cup Point	1
6	K0428	HHCS 5/16"-24 x 1" GR8	1
7	K0043	Lock Washer 5/16"	1

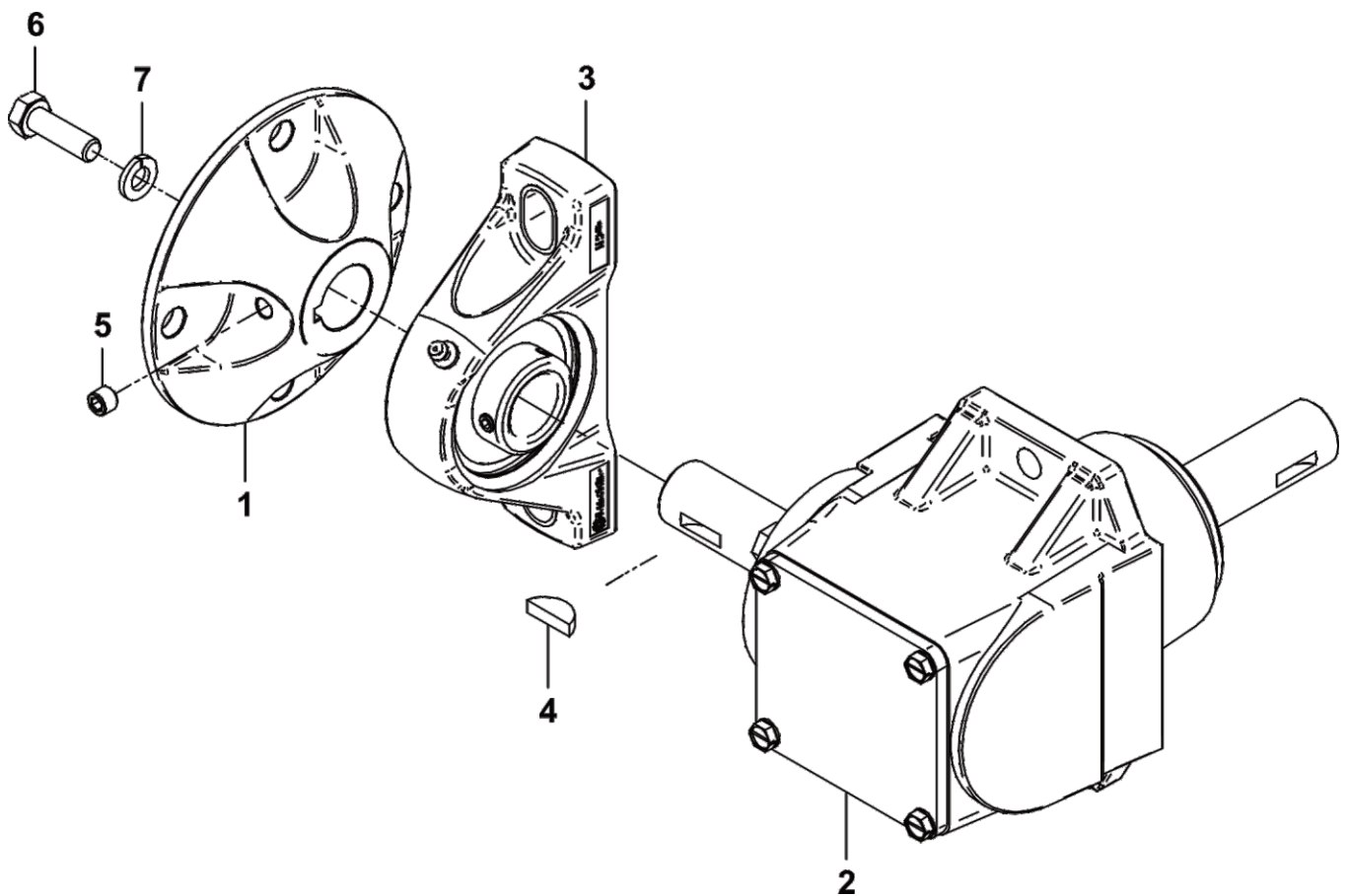



## A2059 02 Clutch Sub-Assembly Exploded Parts View

Item #	Part #	Desc.	Qty.
1	M0001_01	Electric Clutch	1
2	S0007	Clutch Shaft (Rev 1)	1
3	N0004	Flange Bearing / 1" ID / 2-Bolt	1
4	B2217	Clutch Lower Bearing Mnt.	1
5	S0239	Eng. Pulley Bushing #41	1
6	K0076	Key 1/4" x 3/4" Long	1
7	M0309	A-Section Pulley / 4.75 OD (PTO-X)	1
8	K1510	HHCS 3/8"-16 x 1-1/8" GR5 Zinc	2
9	K1121	3/8"-16 Nyloc Nut GR5	2
10	K0359	HHCS / 7/16"-20 x 4" w/ Patch	1
11	K0140	Lock Washer 7/16" / High-Collar Helical Spring	1
12	K0278	Double Indented Washer 7/16" / 1.375 OD x .440 ID x .179 T	1

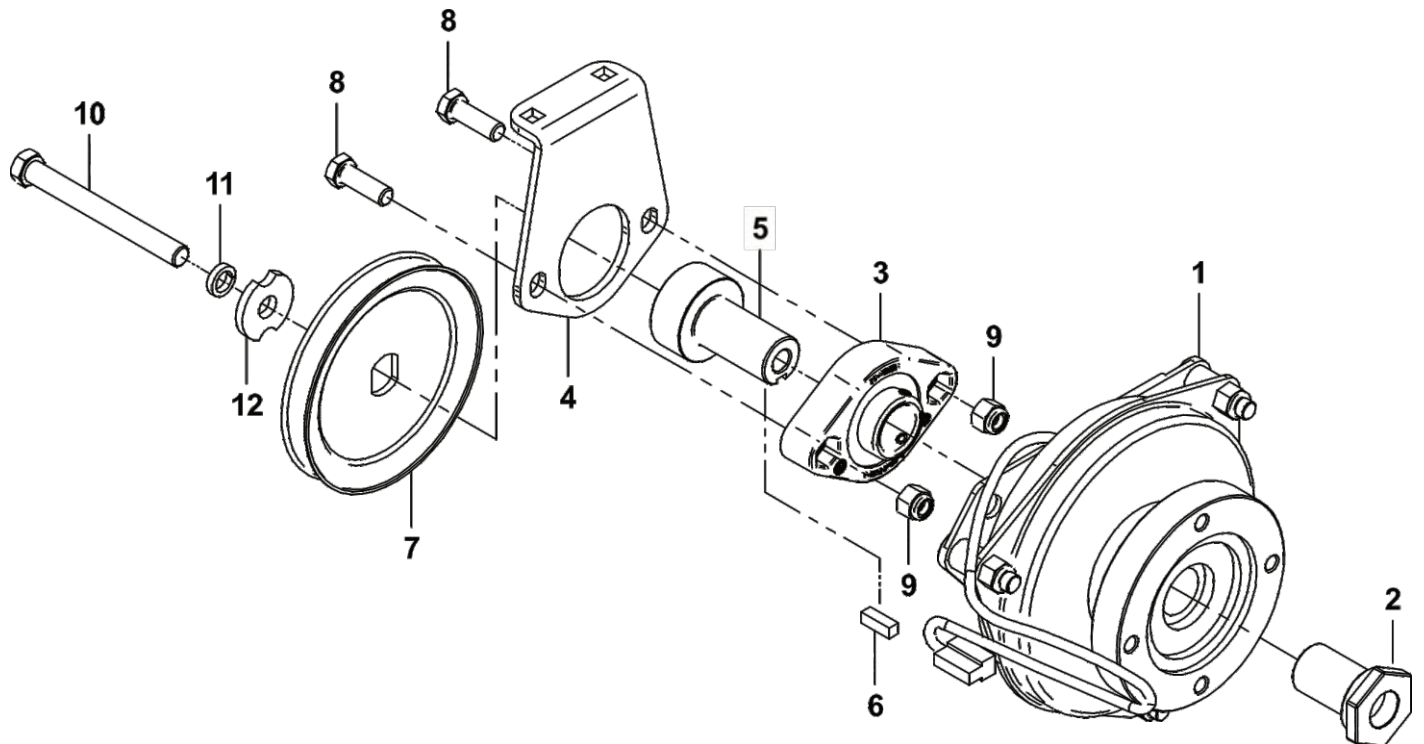

# A2057 02 Drive Assembly Exploded Parts View

Item #	Part #	Desc.	Qty.
1	A2058_01	Gearbox Sub-Assy	1
2	A2059_02	Clutch Sub-Assy	1
3	K0343	HHCS 3/8"-16 x 7/8" GR8	4
4	K0048	Lock Washer 3/8"	4

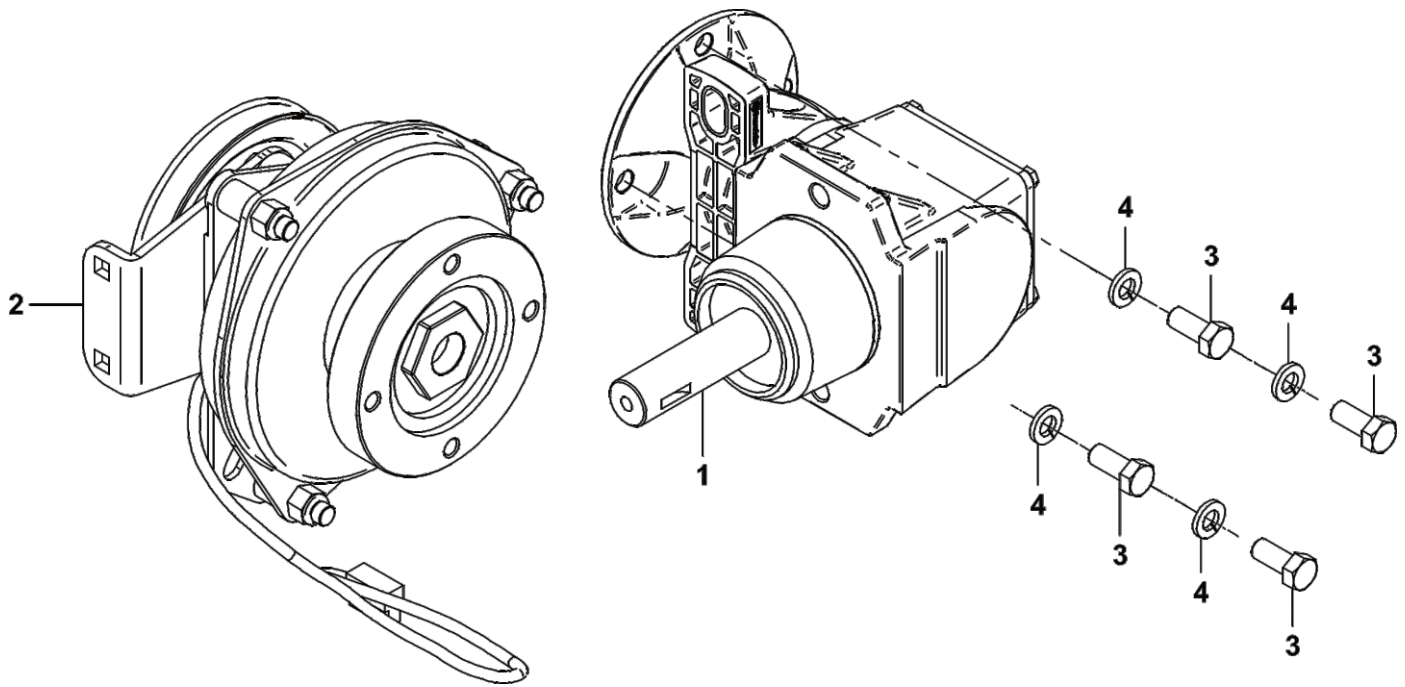

**A2060 02 Mounted Drive Assembly**  
**Exploded Parts View**

Item #	Part #	Desc.	Qty.
1	A2034	Drive Mnt Assy	1
2	A2057_02	Drive Assy	1
3	B0940	Spacer Plate	1
4	K1511	SHCS 1/2"-13 x 2" A574 Zinc	2
5	K0057	Lock Washer I/T 1/2" / Zinc	2
6	K1512	SHCS 3/8"-16 x 1" A574 Zinc	2
7	K0048	Lock Washer 3/8"	2

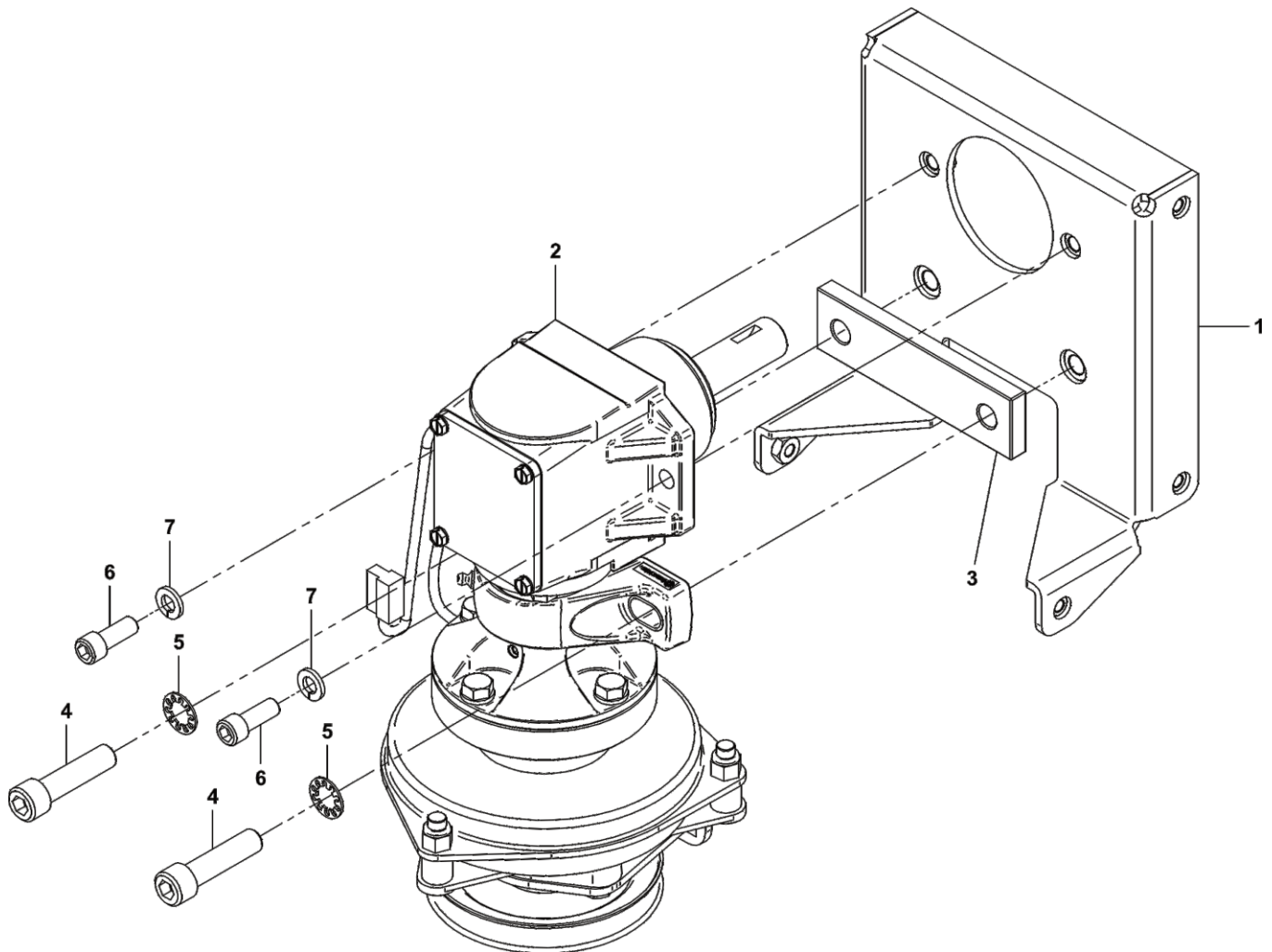

# A2039 03 Base Drive Assembly

## Exploded Parts View

Item #	Part #	Desc.	Qty.
1	A2060_02	Mounted Drive Assy	1
2	A2035_02	Housing Mnt Assy	1
3	B1100_01	Idler Assy Mount Plate	1
4	B0942_02	Anti-Rotation Brkt	1
5	A2032	Drive Arm Assy	1
6	B0938_01	Drive Guard	1
7	K1153	HHCS 5/16"-18 x 3/4"	4
8	K1154	HHCS 5/16"-18 x 1"	4
9	K0043	Lock Washer 5/16"	8
10	K1142	5/16"-18 x 3/4" Carriage Bolt	6
11	K2516	Ny-Flange Lock Nut 5/16"-18	6
12	K0343	HHCS 3/8"-16 x 7/8" GR8	1
13	K1477	Flat Washer / 3/8" / .406 ID x .812 OD x .125 Thk	1
14	K1476	Reverse Lock Nut / 3/8"-16 Grade C	1
15	P0271	Quick Connect Wire Harness	1
16	K0353	HWHTCS 1/4"-20 x 1/2"	2

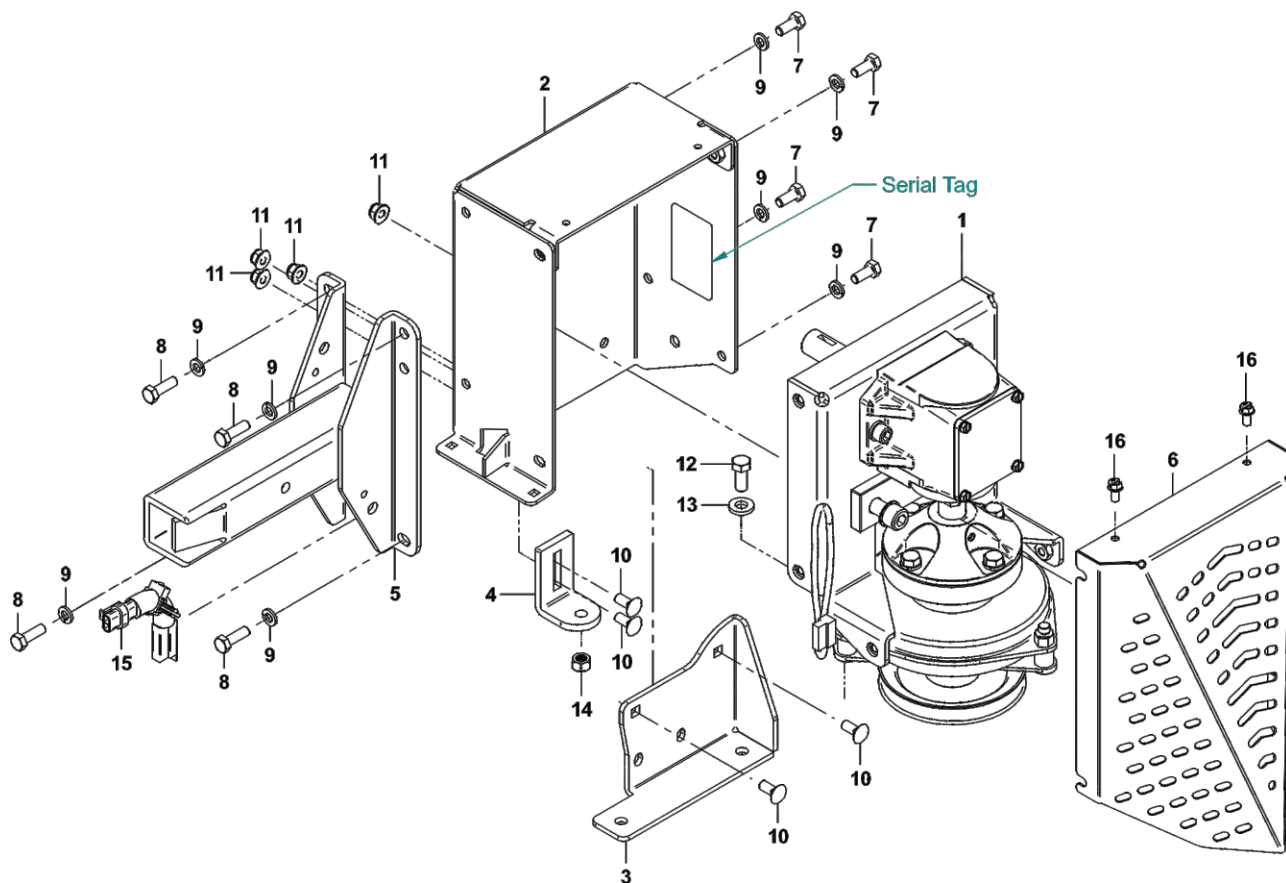

# A2061 03 Drive Assembly / 4 Blade Impeller

## Exploded Parts View

Item #	Part #	Desc.	Qty.
1	A2039 03	Drive Assy / Base 1.5	1
2	A0645	4-Blade Impeller Weldment	1
3	E4052B	Blower Hsg Back	1
4	E4052F	Blower Hsg Front	1
5	K1154	HHCS 5/16"-18 x 1"	4
6	K0044	I/T Tooth Lock Washer 5/16"	4
7	S0157	Taperlock Bushing 7/8"	1
8	K1225	HHCS 1/4"-20 X 1" GR8	2
9	S0159	Spacer Bushing .938 OD x .325 ID x .345 T	1
10	K0042	Flat Washer 5/16" / .875 OD x .380 ID x .075 T	2
11	K0284	Double Indented Washer 3/8" / 1.375 OD x .380 ID x .179 T	1
12	K1465	HHCS 5/16"-24 x 1-1/2" GR8	1
13	K1401	1/4"-20 x 1" SHCS / Zinc / GR8	7
14	K1126	Flange Nut 1/4"-20	7

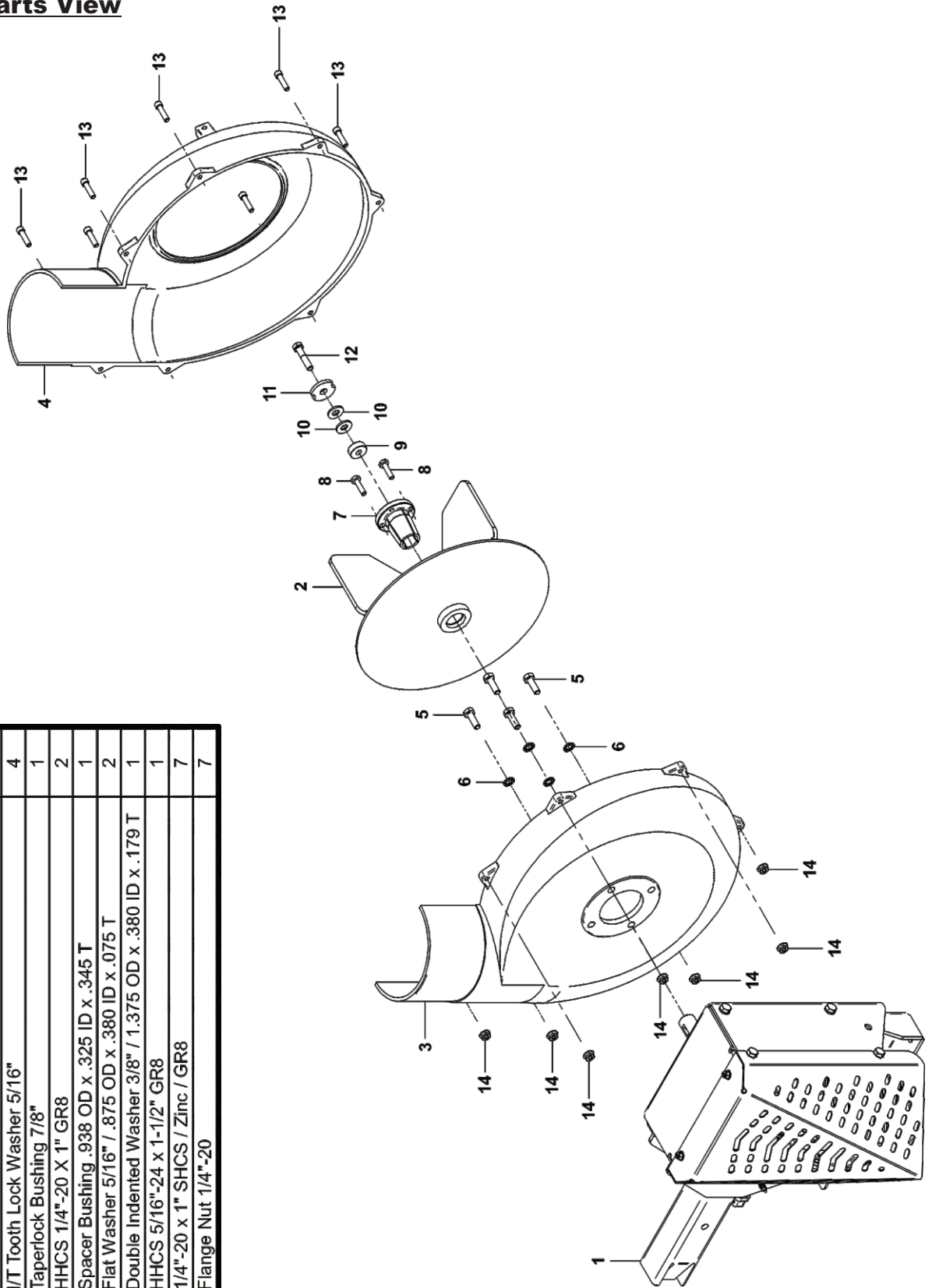

# A1158 Top Assembly Exploded Parts View

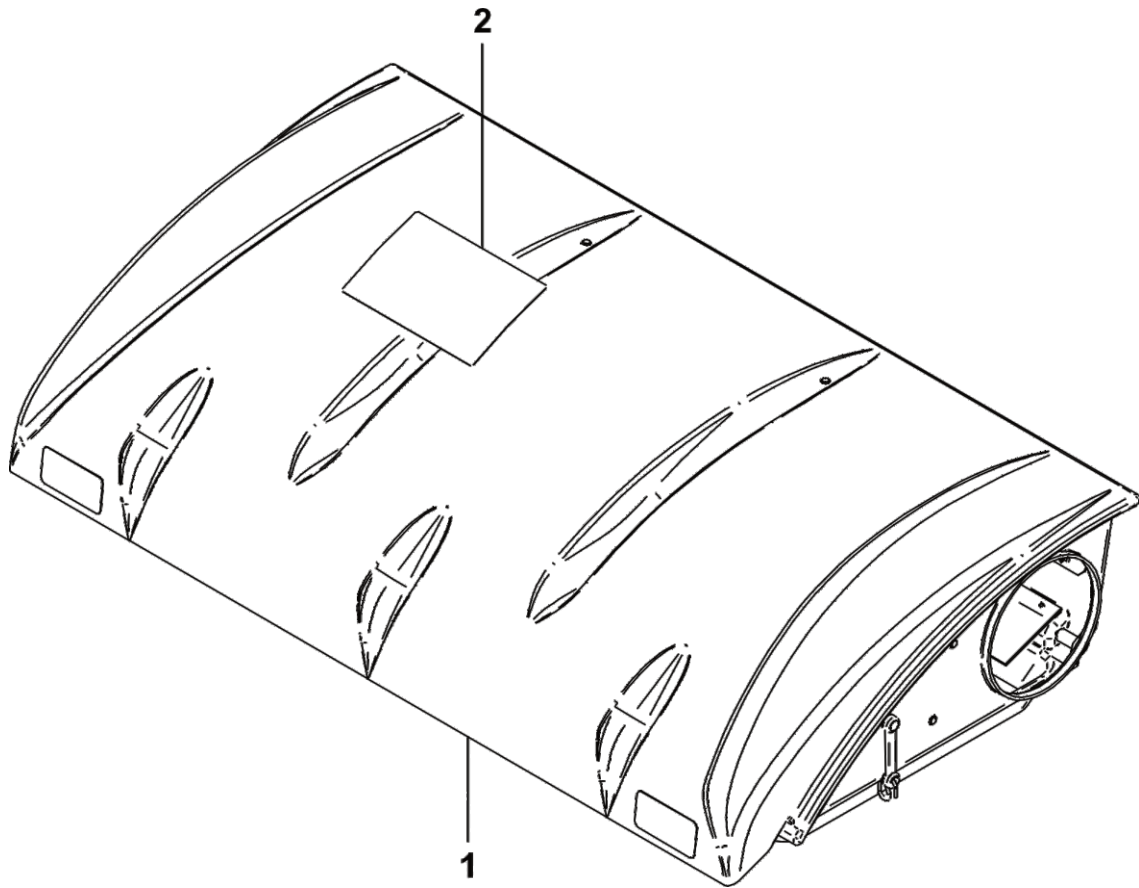

Item #	Part #	Desc.	Qty.
1	A1157	Top Assy / P3B / Standard Model	1
2	R1070	PECO Logo Decal	1

## A1157 Top Assembly Exploded Parts View

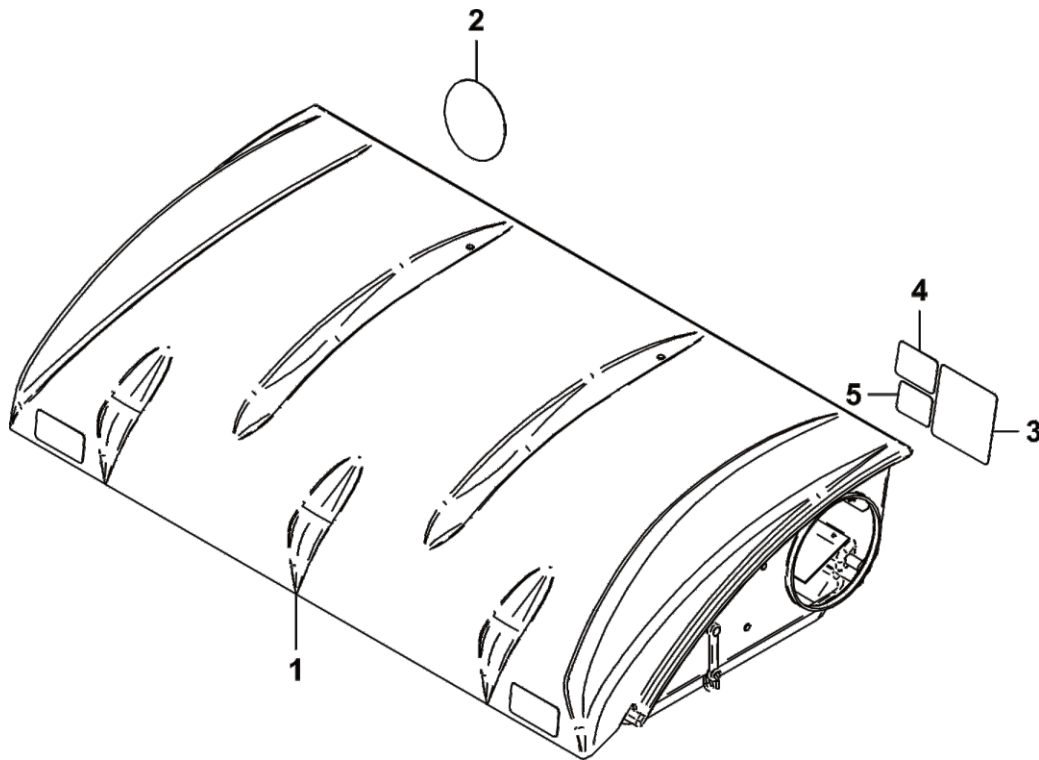

Item #	Part #	Desc.	Qty.
1	A2223	Top Assy. / P3B / Base Model	1
2	R0022	Decal / Built In The USA / Lg	1
3	R1069	Decal / Warning - Turn Off Blower	1
4	R1054	Decal / Important Check Hoses	1
5	R1051	Decal / Warning - Use Hearing Protection	1

## A2223 Top Assembly Exploded Parts View

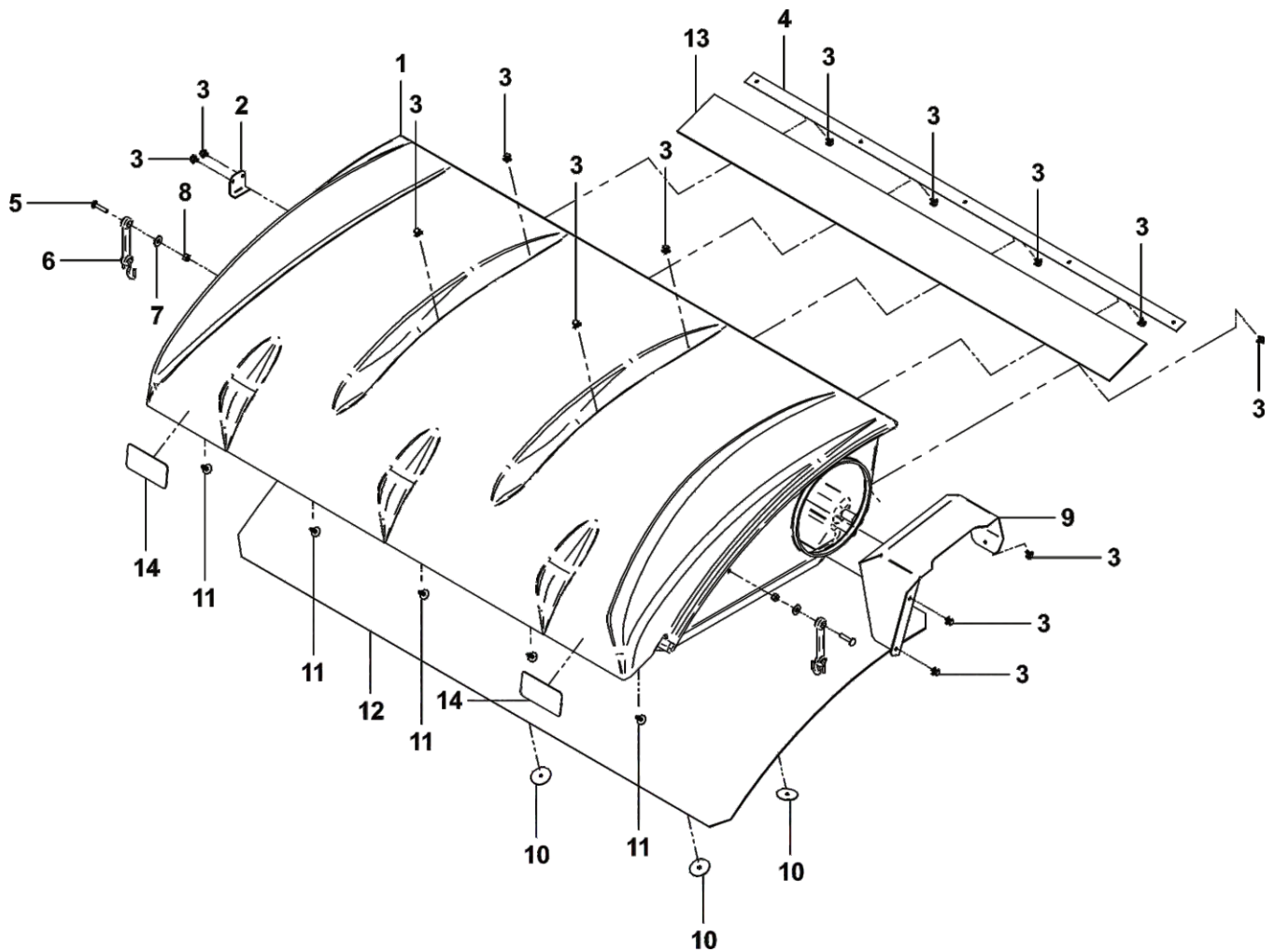

Item #	Part #	Desc.	Qty.
1	V0022	Pro 3 Bagger Top	1
2	B0676	Hinge Stop Pl.	1
3	K0114	Black Plastic Rivet	14
4	C0069	Dust Guard Brace	1
5	K1030	1/4"-20 x 1-1/4" Carriage Bolt	2
6	J4009	Short Rubber Strap w/ S-Hook	2
7	K0037	Flat Washer / 1/4" (.75 OD x .312 ID x .060 T)	2
8	K1128	1/4"-20 Nyloc Nut	2
9	C0026	Grass Deflector	1
10	K0062	Fender Washer / .230 ID x 1.500 OD / Zinc	3
11	K1265	Black Panel Retainer	5
12	V1120	Black Plastic Screen	1
13	V1118	Dust Guard	1
14	R1057	Decal / 2" x 4" Red Reflector	2



# Unit Model #: 38131510

Mower: Dixie Chopper Eagle HP / Jacobsen ZT1000

Owner's Manual: Q0577

Mower Type:

Deck Size: 60", 66" & 72"

Vac Type: 15 Cubic Foot Pro 3B

Deck Type:

Drive Type: PTO-X Drive

Revision #: 1 - PTO-X 1.5 - 7/23/24 - BS

Fits Year(s): 2018 - 2020



## A2322 Vac Kit

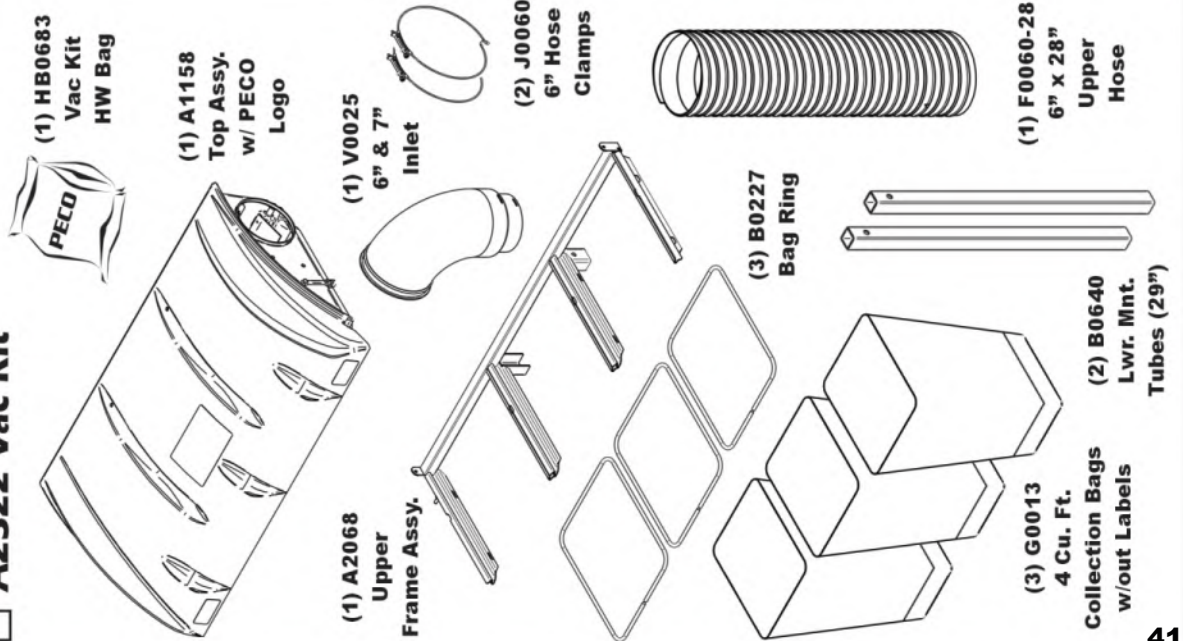

## A2354 Mount Kit

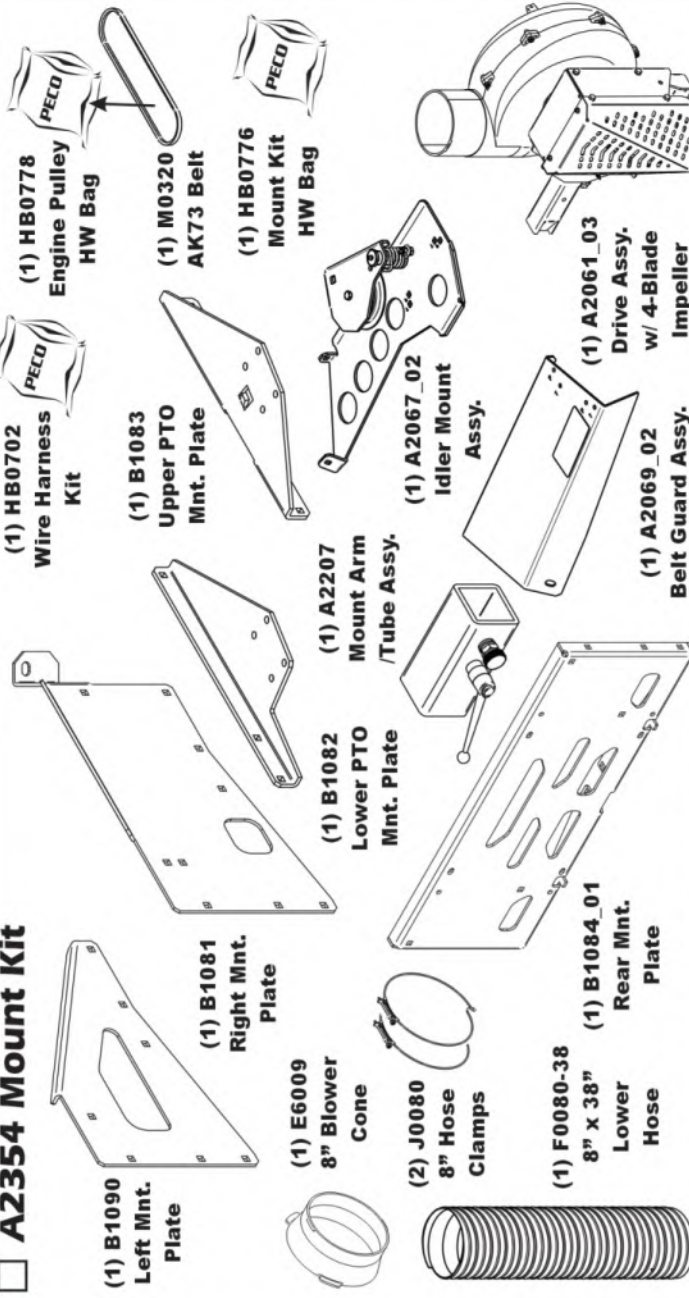

## A2375 Dual Weight Kit

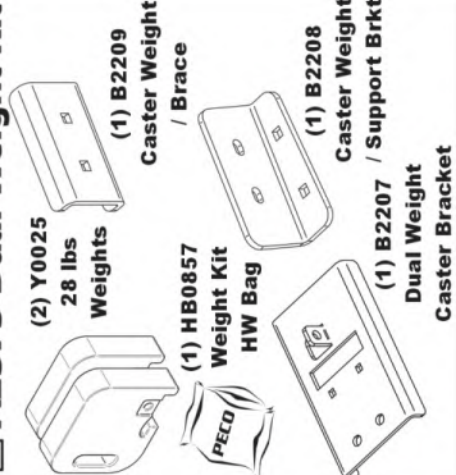

## A2376 Quad Weight Kit

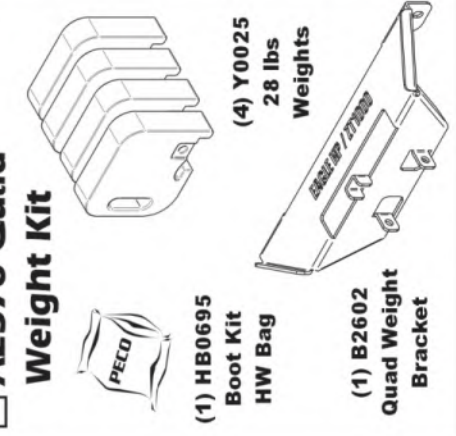

## A2130 Boot Kit

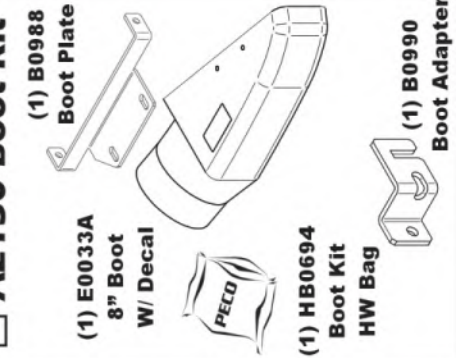

# SAFETY DECALS

To promote safe operation, New PECO, Inc. supplies safety decals on all products manufactured. Damage can occur to safety decals either through shipment, use or reconditioning. Contact your local Service Center for replacement decals.



Part# R1070  
PECO Logo



Part# R0022  
Designed & Built  
In The USA



Part #: R2007  
Danger - Never Use Hands



Part #: R2008  
Danger - Rotating Blades



Part #: R1054  
Important - Hose Wear

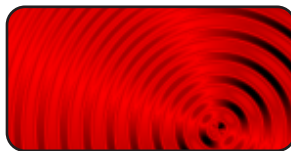
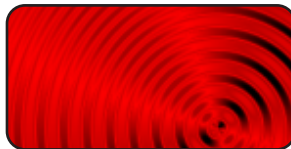

Part #: R1057 - (2)  
Red Reflectors



Part #: R1069  
Warning - Turn Off Blower



Part # R0024  
Danger - Keep Hands  
Clear



Part #: R1051  
Warning - Hearing Protection



Part # R0025  
Danger - Rotating  
Blades

## SECTION III OPERATING INSTRUCTIONS

### General Safety

Only qualified people familiar with this operator's manual and the mower's operator's manual should operate this machine.

### Operation And Tips On Mowing

- A. Perform BEFORE EACH USE the maintenance list referenced in Section IV.
- B. Start mower.
- C. With the mower at high idle speed, engage the mower deck.
- D. While seated in the operator's seat, move Bagger PTO switch to the on position. With the PTO assembly engaged, you can proceed to operate the control levers of the mower.

**NOTE:** If the collection system does not appear to be collecting the grass clippings, disengage the deck and PTO assembly, then, engage the parking brake and turn the mower off. Check upper and lower hoses for any clogs.

To obtain the maximum effectiveness from your collection system, the tips listed below should be followed:

- \* Watch your speed- Normal conditions will allow a speed of up to approximately 4 mph, but thick, heavy damp conditions will require reduced ground speed.
- \* Mow with sharp blades- A sharp blade cuts cleaner.
- \* Wet grass and leaves will decrease effectiveness and will increase horsepower requirements.
- \* Mow at higher cutting heights- Remove and mulch no more than 2" of grass length with each mowing. (Experts recommend not cutting off more than 1/3 of the grass blade length at any given time.)
- \* Mow twice, at different height settings, (high, then low), if grass is extra tall.
- \* Remember that horsepower requirements will vary with the mowing conditions such as type and height of turf grass, moisture content, amount of leaves, whether the terrain is flat or hilly, etc.

### Disengagement Of The PTO Assembly

- A. To disengage the PTO assembly, move Bagger PTO switch to the off position.

**WARNING:** The PTO assembly blades will continue to spin. DO NOT TOUCH the PTO assembly, pulleys, or the belt until the tractor is turned off. DO NOT adjust the belt tension until the mower is turned off. Refer to the Belt Installation section of the manual.

### Unloading The Collection System

**NOTE:** To determine when the collection bags are full, follow the following steps:

- A. Stop the forward movement of the mower.
- B. Disengage the mower deck.
- C. Disengage the PTO assembly.
- D. Engage the parking brake.
- E. Once the parking brake has been engaged, then and only then, walk behind the mower and check the collection bags by first unhooking the rubber strap with S-hook that secures the plastic top, then lift the plastic hood. Load in bags should not exceed the height of the installed bag.
- F. To remove the bags from the frame, slide bags out and turn bags over to deposit clippings.
- G. Slide empty bags back onto the frame and secure plastic top with the rubber strap with S-hook.

**NOTE:** Do not allow collection bags to become over-filled as potential damage may occur to your equipment. Also, be sure to clean the hood screen as needed.

## SECTION IV MAINTENANCE

### Maintenance Checklist

Before each use:

1. Check blades and spindles to be sure that no foreign objects, such as wire or steel strapping bands, are wrapped around them.
2. Inspect blades for wear. Replace if necessary. If it is necessary to sharpen the blades, remove the blades from the spindles before sharpening. DO NOT sharpen blades while still attached to the mower.

3. Make sure all shields are in place and in good condition. Repair or replace any missing or damaged shields.
4. Perform lubrication per instructions.
5. Listen for abnormal sounds, which might indicate loose parts, damaged bearings, or other damage. Correct any deficiency before continuing operation.
6. With the engine off, engage the blower assembly. Check the belt tension and inspect the pulley belt for cracks or tears.
7. Check for wear or deterioration of the upper or lower hoses. If there are any portions of the hose that have been torn or worn through, replace immediately.

After Each Use:

1. Clean all debris from machine especially from the container, underneath the belt shields, and safety decals. Replace any missing or illegible decals.
2. Inspect the unit for worn or damaged components. Repair or replace before the next use. Any replacement component installed during repair shall include the component's current safety decal specified by the manufacturers to be affixed to the component.
3. Under normal usage, the bag material is subject to deterioration and wear and should therefore be frequently checked for necessary replacement. Any replacement bag should be checked to ensure compliance with the original manufacturer's recommendations or specifications.
4. Check belt for proper tension.

## 4-2 Lubrication

Gearbox:

**NOTE:** The gearbox is filled with 6.0 oz. of Mobilube HD Plus 80W-90 oil and permanently sealed. There is no need for scheduled lubrication. The oil level should only be checked if a leak is observed or if a change in gearbox noise is noticed.

Operators are recommended to check for leaks weekly. If a leak is observed, both the gasket and the seals are recommended to be replaced.

Replace the oil using 5.5 oz. of the recommended Mobilube HD Plus 80W-90 oil. Be sure to not overfill.

Blower Assembly:

**NOTE:** The following is for older PTO models that contain a greaseable zirc fitting. Newer models contain maintenance-free bearings and are without a greasable fitting.

1. On initial use: Grease the fitting on the blower shaft.
2. Every 25 hours of use: Re-grease the grease fitting.

**NOTE:** Use only white lithium based grease for lubrication of the shaft on the blower assembly.

## SECTION V - PARTS & SERVICE

### 5-1 Parts And Service Information

Collection system owners should record the name and telephone number of their Service Center. Your Service Center will be happy to supply replacement parts, accessories, and do any service or repairs to your collection system. If for any reason your Service Center is unable to service your collection system or supply replacement parts, contact New PECO, Inc. and include the following information on the chart below.

### DOCUMENT THE FOLLOWING INFORMATION FOR FUTURE REFERENCE

**Unit Model Number:** \_\_\_\_\_

**Unit Engine Size:** \_\_\_\_\_

**Unit Serial Number:** \_\_\_\_\_

**Date of purchase:** \_\_\_\_ / \_\_\_\_ / \_\_\_\_

**Dealer/Distributor Name:** \_\_\_\_\_

**Address:** \_\_\_\_\_ **State:** \_\_\_\_\_ **Zip:** \_\_\_\_\_

**Phone Number:** \_\_\_\_\_

**New PECO, Inc.**

**10 Walden Dr | Arden, North Carolina 28704**

**Phone: 1-800-438-5823 | 828-684-1234**

**Fax: 828-684-0858**

**Email: [peco@lawnvac.com](mailto:peco@lawnvac.com)**

**Website: [www.lawnvac.com](http://www.lawnvac.com)**

# TORQUE SPECIFICATIONS

Proper torque for American fasteners used on PECO equipment.  
Recommended Torque in Foot Pounds (Newton Meters).\*

## AMERICAN Bolt Head Markings

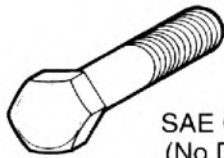

SAE Grade 2  
(No Dashes)

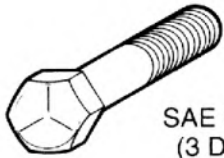

SAE Grade 5  
(3 Dashes)

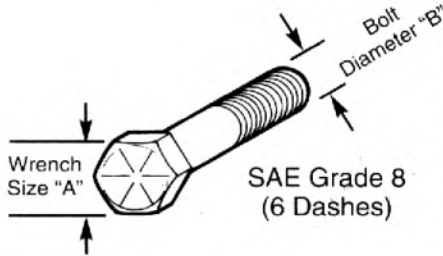

SAE Grade 8  
(6 Dashes)

WRENCH SIZE (IN.) "A"	BOLT DIAMETER (IN.) "B" AND THREAD SIZE	SAE GRADE 2	SAE GRADE 5	SAE GRADE 8
7/16	1/4 - 20 UNC	6 (7)	8 (11)	12 (16)
7/16	1/4 - 28 UNF	6 (8)	10 (13)	14 (18)
1/2	5/16 - 18 UNC	11 (15)	17 (23)	25 (33)
1/2	5/16 - 24 UNF	13 (17)	19 (26)	27 (37)
9/16	3/8 - 16 UNC	20 (27)	31 (42)	44 (60)
9/16	3/8 - 24 UNF	23 (31)	35 (47)	49 (66)
5/8	7/16 - 14 UNC	32 (43)	49 (66)	70 (95)
5/8	7/16 - 20 UNF	36 (49)	55 (75)	78 (106)
3/4	1/2 - 13 UNC	49 (66)	76 (103)	106 (144)
3/4	1/2 - 20 UNF	55 (75)	85 (115)	120 (163)
7/8	9/16 - 12 UNC	70 (95)	109 (148)	153 (207)
7/8	9/16 - 18 UNF	79 (107)	122 (165)	172 (233)
15/16	5/8 - 11 UNC	97 (131)	150 (203)	212 (287)
15/16	5/8 - 18 UNF	110 (149)	170 (230)	240 (325)
1-1/8	3/4 - 10 UNC	144 (195)	266 (360)	376 (509)
1-1/8	3/4 - 16 UNF	192 (260)	297 (402)	420 (569)
1-5/16	7/8 - 9 UNC	166 (225)	430 (583)	606 (821)
1-5/16	7/8 - 14 UNF	184 (249)	474 (642)	668 (905)
1-1/2	1 - 8 UNC	250 (339)	644 (873)	909 (1232)
1-1/2	1 - 12 UNF	274 (371)	705 (955)	995 (1348)
1-1/2	1 - 14 UNF	280 (379)	721 (977)	1019 (1381)
1-11/16	1-1/8 - 7 UNC	354 (480)	795 (1077)	1288(1745)
1-11/16	1-1/8 - 12 UNF	397 (538)	890 (1206)	1444 (1957)
1-7/8	1-1/4 - 7 UNC	500 (678)	1120 (1518)	1817 (2462)
1-7/8	1-1/4 - 12 UNF	553 (749)	1241 (1682)	2013 (2728)
2-1/16	1-3/8 - 6 UNC	655 (887)	1470 (1992)	2382 (3228)
2-1/16	1-3/8 - 12 UNF	746 (1011)	1672 (2266)	2712 (3675)
2-1/4	1-1/2 - 6 UNC	870 (1179)	1950 (2642)	3161 (4283)
2-1/4	1-1/2 - 12 UNF	979 (1327)	2194 (2973)	3557 (4820)

Proper torque for metric fasteners used on PECO equipment.  
Recommended Torque in Foot Pounds (Newton Meters).\*

## METRIC

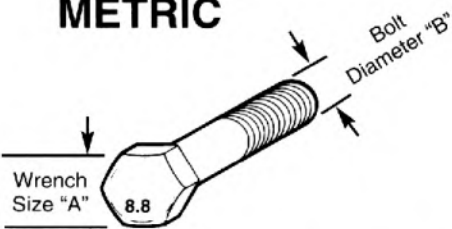

Numbers appearing on bolt heads indicate ASTM class.

WRENCH SIZE (mm) "A"	BOLT DIA. (mm) "B"	ASTM 4.6	ASTM 8.8	ASTM 9.8	ASTM 10.9
8	5	1.8 (2.4)		5.1 (6.9)	6.5 (8.8)
10	6	3 (4)		8.7 (12)	11.1 (15)
13	8	7.3 (10)		21.1 (29)	27 (37)
16	10	14.5 (20)		42 (57)	53 (72)
18	12	25 (34)	74 (100)	73 (99)	93 (126)
21	14	40 (54)	118 (160)	116 (157)	148 (201)
24	16	62 (84)	167 (226)	181 (245)	230 (312)
30	20	122 (165)	325 (440)		449 (608)
33	22		443 (600)		611 (828)
36	24	211 (286)	563 (763)		778 (1054)
41	27		821 (1112)		1138 (1542)
46	30	418 (566)	1119 (1516)		1547 (2096)

\*Use 75% of the specified torque value for plated fasteners. Use 85% of the specified torque values for lubricated fasteners.

# Troubleshooting

2017 (v1.0)

## Collection System Performance

<b>Problem</b>	<b>Possible Cause</b>	<b>Corrective Action</b>
Abnormal Vibration	<ul style="list-style-type: none"> <li>• Cutting blades are bent or unbalanced</li> <li>• Loose blower pulley or pulley assembly</li> <li>• Impeller blade out of balance</li> </ul>	<ul style="list-style-type: none"> <li>• Install new cutting blade</li> <li>• Tighten the pulley</li> <li>• Contact dealer to replace</li> </ul>
Reduced collection system performance	<ul style="list-style-type: none"> <li>• Low engine speed</li> <li>• Plugged screen</li> <li>• Loose belt</li> <li>• Full collection bags</li> </ul>	<ul style="list-style-type: none"> <li>• Always operate collection system at full throttle</li> <li>• Remove debris, leaves, or grass clippings from the screen</li> <li>• Replace/tighten belt</li> <li>• Empty the collection bags</li> </ul>
Blower and hoses plugging too frequently	<ul style="list-style-type: none"> <li>• Collection bags are too full</li> <li>• Low engine speed</li> <li>• Grass is too wet</li> <li>• Grass is too long</li> <li>• Ground speed is too fast</li> <li>• Worn belt</li> <li>• Loose belt</li> </ul>	<ul style="list-style-type: none"> <li>• Dump more frequently</li> <li>• Always operate collection system at full throttle</li> <li>• Cut grass when it is dry</li> <li>• Cut the grass several times</li> <li>• Drive slower at full throttle</li> <li>• Replace belt</li> <li>• Adjust the pulley and tighten belts</li> </ul>
Debris blowout	<ul style="list-style-type: none"> <li>• Collection bags are too full</li> <li>• Plug/clog in the collection system</li> <li>• Ground speed is too fast</li> </ul>	<ul style="list-style-type: none"> <li>• Dump more frequently</li> <li>• Clean the collection system</li> <li>• Drive more slowly at full throttle</li> </ul>
Impeller doesn't rotate freely	<ul style="list-style-type: none"> <li>• Plug in the blower housing</li> <li>• Worn impeller blade</li> <li>• Shaft bearings bad/failing</li> </ul>	<ul style="list-style-type: none"> <li>• Clean the blower housing</li> <li>• Contact dealer to replace</li> <li>• Contact dealer to replace</li> </ul>

## Notes



**New PECO, Inc.**  
**10 Walden Dr | Arden, North Carolina 28704**  
**Phone: 1-800-438-5823 | 828-684-1234**  
**Fax: 828-684-0858**  
**Email: [peco@lawnvac.com](mailto:peco@lawnvac.com)**  
**Website: [www.lawnvac.com](http://www.lawnvac.com)**